



ETA - EUROPEAN TECHNICAL ASSESSMENT

HAC-C

Anchor channel

ETA-17/0336 (29.08.2025)



English 2-54

Deutsch 55-107

Public-law institution jointly founded by the
federal states and the Federation

European Technical Assessment Body
for construction products



European Technical Assessment

ETA-17/0336
of 29 August 2025

English translation prepared by DIBt - Original version in German language

General Part

Technical Assessment Body issuing the
European Technical Assessment:

Deutsches Institut für Bautechnik

Trade name of the construction product

Anchor channels (HAC-C) with channel bolts (HBC)

Product family
to which the construction product belongs

Anchor channels

Manufacturer

Hilti AG
Feldkircherstraße 100
9494 Schaan
FÜRSTENTUM LIECHTENSTEIN

Manufacturing plant

Hilti Manufacturing Plants

This European Technical Assessment
contains

53 pages including 3 annexes which form an integral part
of this assessment

This European Technical Assessment is
issued in accordance with Regulation (EU)
No 305/2011, on the basis of

EAD 330008-04-0601, Edition 07/2024

This version replaces

ETA-17/0336 issued on 18 July 2024

The European Technical Assessment is issued by the Technical Assessment Body in its official language. Translations of this European Technical Assessment in other languages shall fully correspond to the original issued document and shall be identified as such.

Communication of this European Technical Assessment, including transmission by electronic means, shall be in full. However, partial reproduction may only be made with the written consent of the issuing Technical Assessment Body. Any partial reproduction shall be identified as such.

This European Technical Assessment may be withdrawn by the issuing Technical Assessment Body, in particular pursuant to information by the Commission in accordance with Article 25(3) of Regulation (EU) No 305/2011.

Specific Part

1 Technical description of the product

The anchor channels (HAC-C) with channel bolts (HBC) are a system consisting of C-shaped channel profile of carbon steel or stainless steel and at least two metal anchors non-detachably fixed to the channel back and channel bolts.

The anchor channel is embedded surface-flush in the concrete. Channel bolts (HBC) with appropriate hexagon nuts and washers are fixed to the channel.

The product description is given in Annex A.

2 Specification of the intended use in accordance with the applicable European Assessment Document

The performances given in Section 3 are only valid if the anchor channel is used in compliance with the specifications and conditions given in Annex B.

The verifications and assessment methods on which this European Technical Assessment is based lead to the assumption of a working life of the anchor channel of at least 50 years. The indications given on the working life cannot be interpreted as a guarantee given by the producer, but are to be regarded only as a means for choosing the right products in relation to the expected economically reasonable working life of the works.

3 Performance of the product and references to the methods used for its assessment

3.1 Mechanical resistance and stability (BWR 1)

Essential characteristic	Performance
Characteristic resistance under tension load (static and quasi-static loading)	
- Resistance to steel failure of anchors	$N_{Rk,s,a}$ see Annex C1 and C2
- Resistance to steel failure of the connection between anchors and channel	$N_{Rk,s,c}$ see Annex C1 and C2
- Resistance to steel failure of channel lips and subsequently pull-out of channel bolt	$N_{Rk,s,l}^0 ; s_{l,N}$ see Annex C1 and C2
- Resistance to steel failure of channel bolt	$N_{Rk,s}$ see Annex C14
- Resistance to steel failure by exceeding the bending strength of the channel	s_{max} see Annex B3 and B4 $M_{Rk,s,flex}$ see Annex C3
- Maximum installation torque to avoid damage during installation	$T_{inst,g} ; T_{inst,s}$ see Annex B5
- Resistance to pull-out failure of the anchor	$N_{Rk,p}$ see Annex C4 to C6
- Resistance to concrete cone failure	h_{ef} see Annex B3 and B4 $k_{cr,N} ; k_{ucr,N}$ see Annex C4 to C6
- Minimum edge distances, spacing and member thickness to avoid concrete splitting during installation	s_{min} see Annex B3 and B4 $c_{min} ; h_{min}$ see Annex B3 and B4
- Characteristic edge distance and spacing to avoid splitting of concrete under load	$s_{cr,sp} ; c_{cr,sp}$ see Annex C4 to C6
- Resistance to blowout failure - bearing area of anchor head	A_h see Annex A6

Essential characteristic	Performance
<p>Characteristic resistance under shear load (static and quasi-static loading)</p> <ul style="list-style-type: none"> - Resistance to steel failure of channel bolt under shear loading without lever arm - Resistance to steel failure by bending of the channel bolt under shear load with lever arm - Resistance to steel failure of channel lips, steel failure of connection between anchor and channel or steel failure of anchor (shear load in transverse direction) - Resistance to steel failure of connection between channel lips and channel bolt (longitudinal shear) - Factor for sensitivity to installation (longitudinal shear) - Resistance to steel failure of the anchor (longitudinal shear) - Resistance to steel failure of connection between anchor and channel (longitudinal shear) - Resistance to concrete pry-out failure - Resistance to concrete edge failure 	<p>$V_{Rk,s}$ see Annex C15</p> <p>$M_{Rk,s}^0$ see Annex C16</p> <p>$V_{Rk,s,l,y}$; $S_{l,V}$; $V_{Rk,s,c,y}$; $V_{Rk,s,a,y}$ see Annex C8 and C9</p> <p>$V_{Rk,s,l,x}$ see Annex C10</p> <p>γ_{inst} see Annex C10</p> <p>$V_{Rk,s,a,x}$ see Annex C8 and C9</p> <p>$V_{Rk,s,c,x}$ see Annex C8 and C9</p> <p>k_8 see Annex C11</p> <p>$k_{cr,V}$; $k_{ucr,V}$ see Annex C11</p>
<p>Characteristic resistance under combined tension and shear load (static and quasi-static load)</p> <ul style="list-style-type: none"> - Resistance to steel failure of the anchor channel 	<p>k_{13} ; k_{14} see Annex C13</p>
<p>Characteristic resistance under fatigue tension loading</p> <ul style="list-style-type: none"> - Fatigue resistance to steel failure of the whole system (continuous or tri-linear function, assessment method A1, A2) - Fatigue limit resistance to steel failure of the whole system (assessment method B) - Fatigue resistance to steel failure of the whole system (linearized function, assessment method C) - Fatigue resistance to concrete related failure (exponential function, assessment method A1, A2) - Fatigue limit resistance to concrete related failure (assessment method B) - Fatigue resistance to concrete related failure (linearized function, assessment method C) 	<p>$\Delta N_{Rk,s,0,n}$ ($n = 1$ to $n = \infty$) see Annex C18</p> <p>$\Delta N_{Rk,s,0,\infty}$ see Annex C20</p> <p>No performance assessed</p> <p>$\Delta N_{Rk,c,0,n}$ $\Delta N_{Rk,p,0,n}$ ($n = 1$ to $n = \infty$) see Annex C19</p> <p>$\Delta N_{Rk,c,0,\infty}$ $\Delta N_{Rk,p,0,\infty}$ see Annex C 20</p> <p>No performance assessed</p>

Essential characteristic	Performance
Characteristic resistance under seismic loading (seismic performance category C1) - Resistance to steel failure under seismic tension loading (seismic performance category C1) - Resistance to steel failure under seismic shear loading for shear load in transverse direction (seismic performance category C1) - Resistance to steel failure under seismic shear loading for shear load in longitudinal channel axis (seismic performance category C1)	$N_{Rk,s,a,eq}$; $N_{Rk,s,c,eq}$; $N^0_{Rk,s,l,eq}$ see Annex C21 $M_{Rk,s,flex,eq}$ see Annex C22 $N_{Rk,s,eq}$ see Annex C24 $V_{Rk,s,eq}$ see Annex C24 $V^0_{Rk,s,l,y,eq}$; $V_{Rk,s,c,y,eq}$; $V_{Rk,s,a,y,eq}$ see Annex C22 $V_{Rk,s,l,x,eq}$ see Annex C23 $V_{Rk,s,a,x,eq}$; $V_{Rk,s,c,x,eq}$ see Annex C22
Characteristic resistance under static and quasi-static tension and/or shear loading - Displacements	δ_{N0} ; $\delta_{N\infty}$ see Annex C7 $\delta_{V,y,0}$; $\delta_{V,y,\infty}$; $\delta_{V,x,0}$; $\delta_{V,x,\infty}$ see Annex C12 and C13

3.2 Safety in case of fire (BWR 2)

Essential characteristic	Performance
Reaction to fire	Class A1
Resistance to fire	$N_{Rk,s,fi}$; $V_{Rk,s,y,fi}$ see Annex C25 and C26

3.3 Aspects of durability linked with the Basic Works Requirements

Essential characteristic	Performance
Durability	See Annex B1

4 Assessment and verification of constancy of performance (AVCP) system applied, with reference to its legal base

In accordance with EAD No. 330008-04-0601, the applicable European legal act is: [2000/273/EC].

The system to be applied is: 1

5 Technical details necessary for the implementation of the AVCP system, as provided for in the applicable EAD

Technical details necessary for the implementation of the AVCP system are laid down in the control plan deposited with Deutsches Institut für Bautechnik.

The following standards are referred to in this European Technical Assessment:

EN 10025-1:2004	Hot rolled products of structural steels - Part 1: General technical delivery conditions
EN 10149-1:2013	Hot rolled flat products made of high yield strength steels for cold forming - Part 1: General technical delivery conditions
EN 10263-1:2017	Steel rod, bars and wire for cold heading and cold extrusion - Part 1: General technical delivery conditions
EN ISO 898-1:2013	Mechanical properties of fasteners made of carbon steel and alloy steel - Part 1: Bolts, screws and studs with specified property classes – Coarse thread and fine pitch thread (ISO 898-1:2013)
EN ISO 898-2:2022	Fasteners - Mechanical properties of fasteners made of carbon steel and alloy steel – Part 2: Nuts with specified property classes (ISO 898-2:2022)
EN ISO 7089:2000	Plain washers – Normal series, Product grade A (ISO 7089:2000)
EN ISO 7093-1:2000	Plain washers - Large series - Part 1: Product grade A (ISO 7093-1:2000)
EN ISO 4032:2023	Fasteners – Hexagon regular nuts (style 1) (ISO 4032:2023)
DIN 934:1987-10	Hexagon nuts with metric coarse and fine pitch thread; product grades A and B
EN ISO 1461:2022	Hot dip galvanized coatings on fabricated iron and steel articles - Specifications and test methods (ISO 1461:2022)
EN ISO 4042:2022	Fasteners - Electroplated coating systems (ISO 4042:2022)
EN ISO 10684:2004 + AC:2009	Fasteners - Hot dip galvanized coatings (ISO 10684:2004 + Cor. 1:2008)
EN 10088-1:2023	Stainless steels - Part 1: List of stainless steels
EN ISO 3506-1:2020	Fasteners - Mechanical properties of corrosion-resistant stainless steel fasteners - Part 1: Bolts, screws and studs with specified grades and property classes (ISO 3506-1:2020)
EN 206:2013 + A2:2021	Concrete - Specification, performance, production and conformity
EN 1993-1-4:2006 + A1:2015 + A2:2020	Eurocode 3: Design of steel structures - Part 1-4: General rules - Supplementary rules for stainless steels
EN 1992-4:2018	Eurocode 3: Design of steel structures - Part 4: General rules - Supplementary rules for stainless steels
EOTA TR047:2021-05	Design of anchor channels in addition to EN 1992-4
EOTA TR050:2023-10	Calculation method for the performance of Anchor channels under Fatigue Cyclic Loading

EN 1992-1-1:2023

Eurocode 2: Design of concrete structures -
Part 1-1: General rules - Rules for buildings, bridges and civil
engineering structures

Issued in Berlin on 29 August 2025 by Deutsches Institut für Bautechnik

Dipl.-Ing. Andreas Kummerow
Head of Department

beglaubigt:
Müller

**Product and installed condition
(e.g. hot-rolled channel profile with a round anchor)**

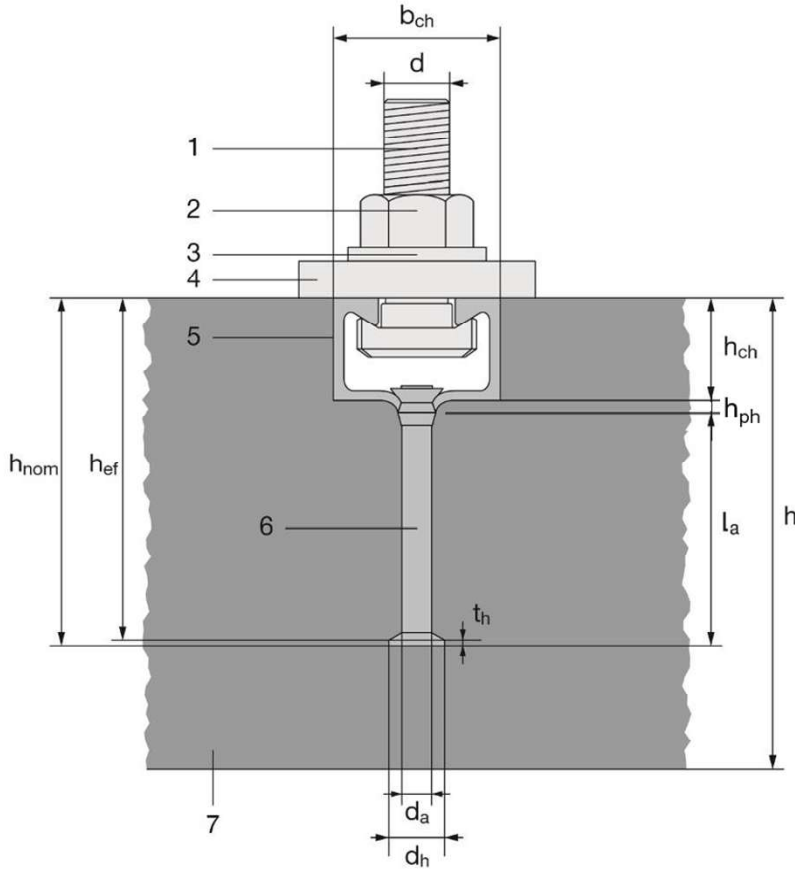

Key

- 1 channel bolt
- 2 hexagonal nut
- 3 washer
- 4 fixture
- 5 channel profile
- 6 anchor
- 7 concrete member

Hilti anchor channels (HAC-C) with channel bolts (HBC)

Product Description
Installed condition

Annex A1

Channel profiles sealing

Channel without additional sealing

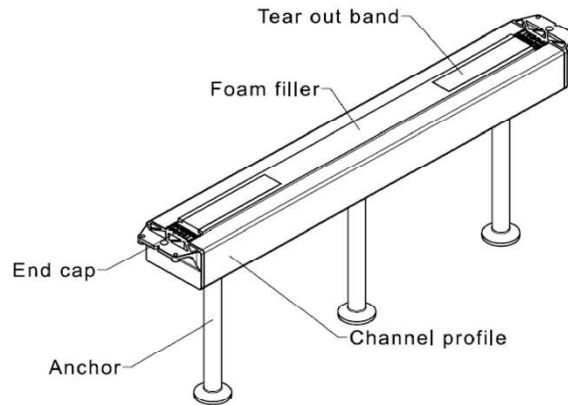

Channel with additional sealing (side sealing)

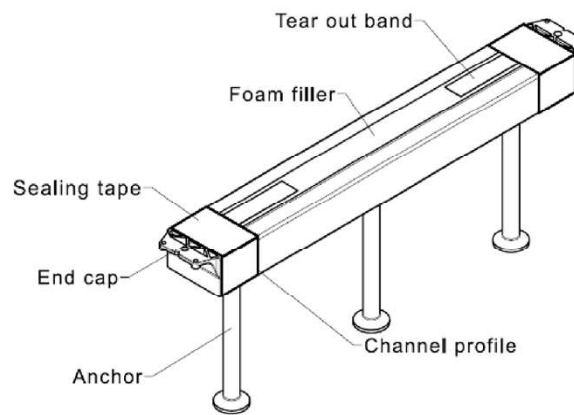

Channel with additional sealing (top sealing)

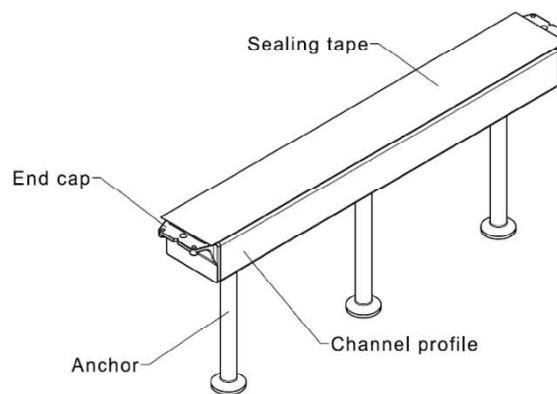

Hilti anchor channels (HAC-C) with channel bolts (HBC)

Product Description
Sealing of the channel profile

Annex A2

Anchor channel types

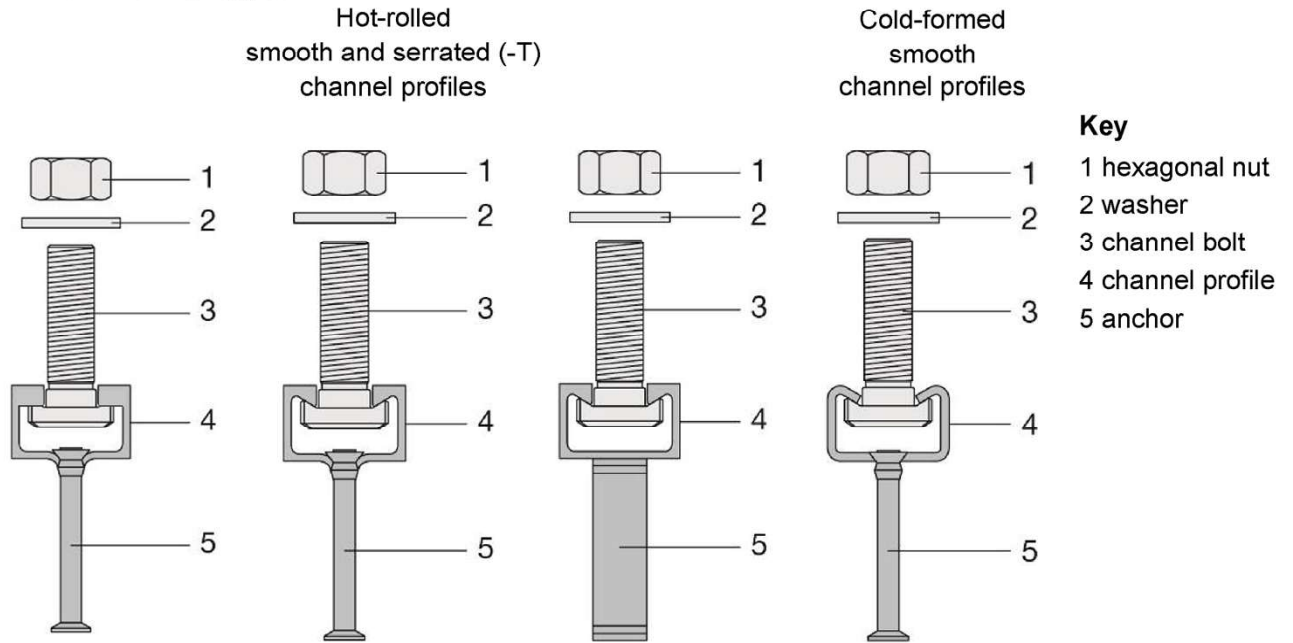

Round anchor
HAC-C-T 29/20,
HAC-C-T 40/22,
HAC-C-T 40L,
HAC-C-T 50/30,
HAC-C-T 50L,
HAC-C-T 53/34

Round anchor or **Welded I-anchor**
HAC-C(-P) 40/22,
HAC-C-P 40L,
HAC-C(-P) 50/30,
HAC-C-P 50L,
HAC-C 52/34

Round anchor
HAC-C 28/15,
HAC-C 38/17,
HAC-C 40/25,
HAC-C 49/30,
HAC-C 54/33

Hilti anchor channels (HAC-C) with channel bolts (HBC)

Product Description
Anchor channel types

Annex A3

Marking of the Hilti anchor channel:

HAC-C(-T)(-P)(-I) X W Z

HAC	= Identifying mark of the manufacturer (H ilti A ncor C hannel)
T	= Additional marking for serrated channels
P	= Additional marking for premium line
I	= Additional marking for I-anchors (no marking in case of round anchors)
X	= Size of the channel
W	= Channel length
Z	= Corrosion protection/material (e.g. F for Hot dip galvanized, A4 or A2 for Stainless steel)

a)

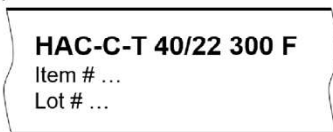

(sticker and/or ink printed mark e.g. on the back side of the channel e.g. HAC-C-T 40/22 300 F)

HAC-C-T	= Serrated anchor channel
40/22 ¹⁾	= Anchor channel size 40/22
F	= Hot dip galvanized
300	= 300 mm channel length (l _{ch})

b)

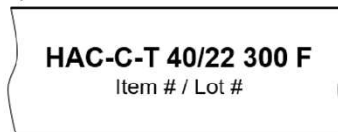

(stamp mark inside of the channel, e.g. HAC-C-T 40/22 F)



Note : ¹⁾ Anchor channel HAC-C-T 40/22 can be produced as well with marking "38/23" without changes in the sizes of the product. The same performance parameters are applicable to 38/23 as they are for 40/22.

Marking of the Hilti channel bolt:

HBC(-T) X (-N) Y Z

HBC	= Identifying mark of the manufacturer (H ilti B olt C hannel)
T	= Additional marking for serrated bolt
X	= Size of the bolt
N	= Additional marking for notching bolt
Y	= Steel grade/strength class
Z	= Corrosion protection/material (e.g. F)

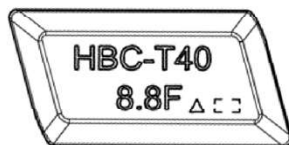

(stamp mark on the back side of the bolt, e.g. HBC-T40 8.8F)

HBC-T	= Serrated bolt (for serrated anchor channel HAC-C-T)
40	= Size of the channel bolt (see Table 3)
8.8	= Strength class 8.8
F	= Hot dip galvanized

Hilti anchor channels (HAC-C) with channel bolts (HBC)

Product Description
Marking of anchor channel and channel bolts

Annex A4

Channel profiles

Hot-rolled serrated channel profiles

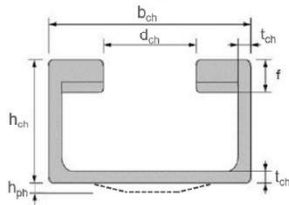

HAC-C-T 29/20,
HAC-C-T 40/22,
HAC-C-T 40L,
HAC-C-T 50/30,
HAC-C-T 50L,
HAC-C-T 53/34

Hot-rolled smooth channel profiles

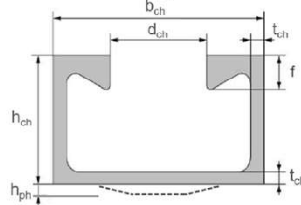

HAC-C(-P) 40/22,
HAC-C-P 40L,
HAC-C(-P) 50/30,
HAC-C-P 50L,
HAC-C 52/34

Cold-formed smooth channel profiles

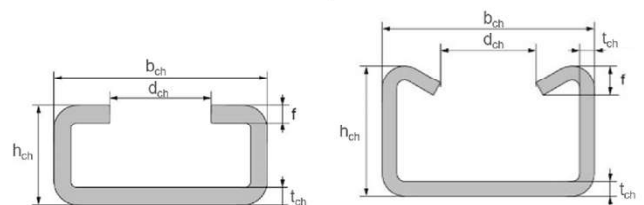

HAC-C 28/15,
HAC-C 38/17

HAC-C 40/25,
HAC-C 49/30,
HAC-C 54/33

Table 1: Dimensions of channel profile

Anchor channel	b _{ch}	h _{ch} ¹⁾	h _{ph} ¹⁾	t _{ch}	d _{ch}	f ²⁾	I _y
	[mm]						[mm ⁴]
HAC-C-T (hot-rolled serrated) channel profiles							
HAC-C-T 29/20	30,4	20,0	1,6	3,2	14,0	5,35	11.832
HAC-C-T 40/22 HAC-C-T 40L	38,0	23,0	2,0	3,25	18,0	6,35	21.570
HAC-C-T 50/30 HAC-C-T 50L	50,0	30,0	2,5	3,4	22,5	7,3	58.546
HAC-C-T 53/34	53,5	34,0	4,0	4,5	22,5	8,50	100.900
HAC-C(-P) (hot-rolled) channel profiles							
HAC-C(-P) 40/22 HAC-C-P 40L	40,1	23,0	1,95	2,7	18,0	6,0	21.504
HAC-C(-P) 50/30 HAC-C-P 50L	49,6	30,0	2,5	3,2	22,5	8,1	57.781
HAC-C 52/34	52,5	34,0	-	4,0	22,5	11,5	97.606
HAC-C (cold-formed) channel profiles							
HAC-C 28/15	28,0	15,5	-	2,3	12,0	2,3	4.277
HAC-C 38/17	38,0	17,25	-	3,0	18,0	3,0	8.224
HAC-C 40/25	40,0	25,0	-	2,75	18,0	5,6	20.122
HAC-C 49/30	50,0	30,0	-	3,25	22,0	7,4	43.105
HAC-C 54/33	53,5	33,0	-	5,0	21,5	8,0	74.706

¹⁾ For hot-rolled serrated and smooth anchor channels – local increase of the channel height (height of the punched hole) in the area where the anchor is connected is not taken into account in the calculation of the h_{ch};

²⁾ For hot-rolled serrated channels (HAC-C-T) height of channel lips includes height of the teeth;

Hilti anchor channels (HAC-C) with channel bolts (HBC)

Product Description
Channel profiles (HAC-C)

Annex A5

Anchors

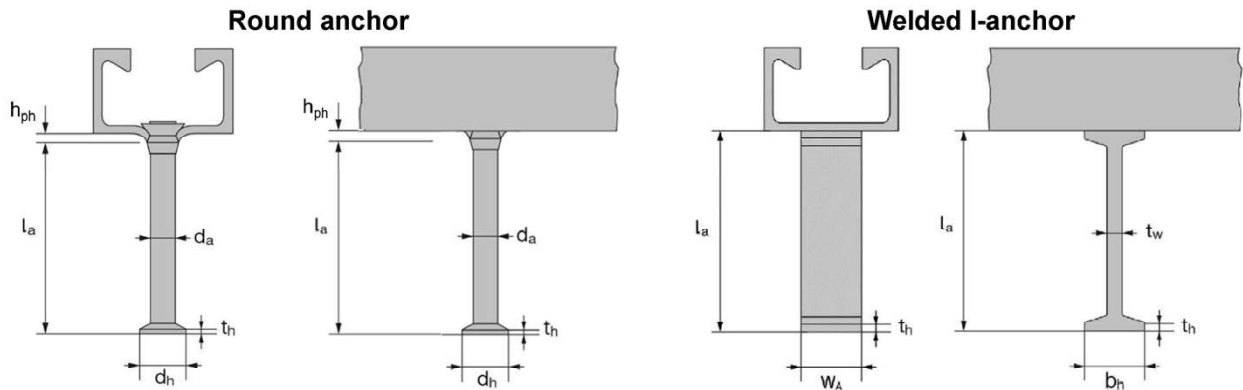

Table 2: Dimensions of anchor (welded I-anchor or round anchor) ¹⁾

Anchor channel	Round anchor					Welded I-anchor					
	min l_a	d_a	d_h	t_h	A_h	min l_a	t_w	b_h	t_h	W_A	A_h
	[mm]				[mm ²]	[mm]					[mm ²]
HAC-C-T (hot-rolled serrated)											
HAC-C-T 29/20	62,4	9,0	18,0	2,0	190,8	- ²⁾					
HAC-C-T 40/22	71,2	10,0	21,5	2,2	284,4	- ²⁾					
HAC-C-T 40L	87,2	10,0	21,5	2,2	284,4	- ²⁾					
HAC-C-T 50/30	101,5	11,0	26,0	2,5	435,9	- ²⁾					
HAC-C-T 50L	141,8	11,0	26,0	2,5	435,9	- ²⁾					
HAC-C-T 53/34	119,5	12,0	26,0	2,5	417,8	- ²⁾					
HAC-C-P (hot-rolled smooth)											
HAC-C 40/22	58,0	8,0	16,0	2,0	151,0	62,0	5,0	20,0	5,0	20,0	300,0
HAC-C-P 40/22	70,0	10,0	21,5	2,2	285,0	125,0	6,0	25,0	5,0	20,0	380,0
HAC-C-P 40L	83,2	10,0	21,5	2,2	285,0	- ²⁾					
HAC-C 50/30	66,0	10,0	20,0	2,2	236,0	69,0	5,0	20,0	5,0	25,0	375,0
HAC-C-P 50/30	78,0	11,0	26,0	2,5	436,0	125,0	6,0	25,0	5,0	25,0	475,0
HAC-C-P 50L	118,3	11,0	26,0	2,5	436,0	- ²⁾					
HAC-C 52/34	123,5	11,0	24,3	2,5	369,0	125,0	6,0	25,0	5,0	40,0	760,0
HAC-C (cold-formed smooth)											
HAC-C 28/15	31,0	6,0	12,0	1,3	85,0	- ²⁾					
HAC-C 38/17	60,8	8,0	16,0	2,0	151,0	- ²⁾					
HAC-C 40/25	56,0	8,0	16,0	2,0	151,0	- ²⁾					
HAC-C 49/30	66,0	10,0	20,0	2,2	236,0	- ²⁾					
HAC-C 54/33	124,5	11,0	24,3	2,5	369,0	- ²⁾					

¹⁾ For cold-formed channel profiles (and for HAC-C 52/34) – $h_{ph} = 0$ and length of the anchor calculated similar to a Welded I-anchor;

²⁾ Product not available;

Hilti anchor channels (HAC-C) with channel bolts (HBC)

Product Description
Anchors

Annex A6

Channel bolts

Table 3: Dimensions of channel bolt

Anchor channel	Channel bolt	Steel grade ¹⁾	Dimensions			
			d	b _{cbo,1}	b _{cbo,2}	t _{cbo}
[mm]						
For hot-rolled serrated (HAC-C-T) channels						
HAC-C-T 29/20	HBC-T 29/20	8.8, A4-70	10	13,5	22,8	8,0
			12	13,5	22,8	8,0
HAC-C-T 40/22	HBC-T 40/22	8.8, A4-70	10	17,1	30,3	9,5
			12	17,1	30,3	9,5
			16	17,1	30,3	9,5
HAC-C-T 50/30 HAC-C-T 53/34	HBC-T 50/30	8.8, A4-70	16	21,0	42,0	13,8
			20	21,0	42,0	13,8
For hot-rolled and/or cold-formed smooth (HAC-C) channels						
HAC-C(-P) 40/22 HAC-C-P 40L HAC-C 40/25	HBC-40/22	8.8, A4-70	10	14,0	33,0	10,5
			12	14,0	33,0	11,5
			16	17,0	33,0	11,5
HAC-C-P 40/22 HAC-C-P 40L	HBC-40/22-N	8.8, A4-70	16	17,0	33,0	11,5
			12	17,0	42,0	14,5
HAC-C 49/30 HAC-C(-P) 50/30 HAC-C-P 50L HAC-C 52/34 HAC-C 54/33	HBC-50/30	8.8, A4-70	16	17,0	42,0	15,5
			20	21,0	42,0	15,5
			16	21,0	42,0	15,5
HAC-C-P 50/30 HAC-C-P 50L HAC-C 52/34	HBC-50/30-N	8.8, A4-70	20	21,0	42,0	15,5
			16	21,0	42,0	15,5
For cold-formed smooth (HAC-C) channels						
HAC-C 38/17	HBC-38/17	8.8, A4-70	10	13,0	30,5	6,0
			12	13,0	30,5	7,0
			16	16,0	30,5	7,0
HAC-C 28/15	HBC-28/15	8.8, A4-70	8	10,1	22,2	5,0
			10	10,1	22,2	5,0
			12	11,0	22,2	8,0

¹⁾ Material properties according to Annex A6

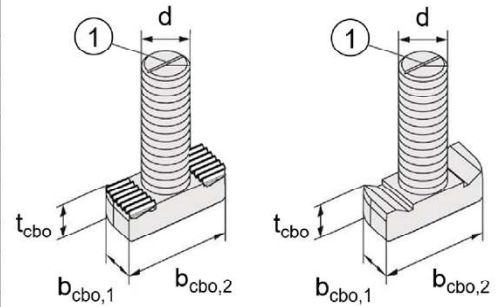

HBC-T 29/20,
HBC-T 40/22,
HBC-T 50/30

HBC-40/22;
HBC-50/30

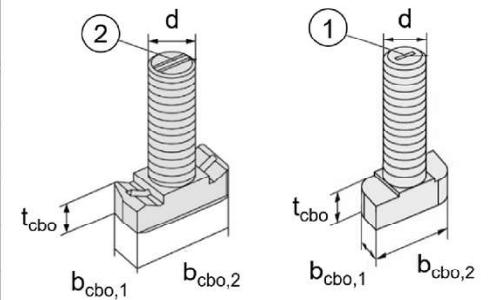

HBC-40/22-N,
HBC-50/30-N

HBC-28/15,
HBC-38/17

Note:
Marking of the bolt's position:
① - Single groove;
② - Double groove

Table 4: Steel grade and corrosion protection

Channel Bolt	Carbon steel ^{1) 2)}	Stainless steel ^{1) 3)}
Steel grade	8.8	A4-70
f _{uk} [N/mm ²]	800 / 830	700
f _{yk} [N/mm ²]	640 / 660	450
Corrosion protection	G ⁴⁾ ; F ⁵⁾	R

¹⁾ Material properties according to Annex A8

²⁾ Material properties according to EN ISO 898-1

³⁾ Material properties according to EN ISO 3506-1

⁴⁾ Electroplated

⁵⁾ Hot dip galvanized

Hilti anchor channels (HAC-C) with channel bolts (HBC)

Product Description
Channel bolts (HBC)

Annex A7

Table 5: Materials

Component	Carbon steel			Stainless steel	
	Material properties	Coating		Material properties	
		2a	2b	2c	3
Channel Profile	1.0038, 1.0044, 1.0045 according to EN 10025-1 1.0976, 1.0979 according to EN 10149-1	Hot dip-galvanized $\geq 55 \mu\text{m}$ ³⁾ Hot dip galvanized $\geq 70 \mu\text{m}$ ⁴⁾ according to EN ISO 1461, Table 3		1.4301 according to EN 10088-1 ³⁾	1.4362, 1.4401 1.4404, 1.4571, 1.4578 according to EN 10088-1 ³⁾
Anchor	1.0038, 1.0213, 1.0214 according to EN 10025-1 1.5523, 1.5535 according to EN 10263-1				
Channel bolt	Steel grade 8.8 according to EN ISO 898-1	Electroplated according to EN ISO 4042	Hot dip galvanized $\geq 50 \mu\text{m}$ according to EN ISO 10684	Grade 70 according to EN ISO 3506-1	
Plain washer ¹⁾ according to EN ISO 7089 and EN ISO 7093-1	Hardness class A $\geq 200 \text{ HV}$	Electroplated according to EN ISO 4042	Hot dip galvanized $\geq 50 \mu\text{m}$ according to EN ISO 10684	1.4401, 1.4404 1.4571, 1.4578 according to EN 10088-1	
Hexagonal nut according to EN ISO 4032 or DIN 934	Property class 8 according to EN ISO 898-2	Electroplated according to EN ISO 4042	Hot dip galvanized $\geq 50 \mu\text{m}$ according to EN ISO 10684	Property class 50, 70 or 80 according to EN ISO 3506-1	

¹⁾ In scope of delivery only for notched bolts

²⁾ Anchors made of carbon steel according to column 2a may also be used if they are welded and their concrete cover is more than 50 mm and tempering colors are removed;

³⁾ Anchor channels according to the Table 5 column 3 have marking "A2" and according to the column 4 marking "A4";

³⁾ For HAC-C-T 29/20; HAC-C(-P) 40/22, 40L; HAC-C 28/15, 38/17, 40/25, 49/30, 54/33;

⁴⁾ For HAC-C-T 53/34, 50/30, 50L, 40/22, 40L; HAC-C(-P) 50/30, 50L, 53/34.

Hilti anchor channels (HAC-C) with channel bolts (HBC)

Product Description
Materials

Annex A8

Specifications of intended use

Working life:

The verification and assessment methods on which this European Technical Assessment is based lead to the assumption of a working life of anchor channel of at least:

- 50 years
(anchor channels and channel bolts made of Carbon steel – according to Annex A8, columns 2a-2c)
- 100 years
(anchor channels and channel bolts made of Stainless steel A4 – according to Annex A8, column 4)

Anchor channels and channel bolts subject to:

- Static and quasi-static tension and shear perpendicular to the longitudinal axis of the channel
- Static and quasi-static shear in the direction of longitudinal axis
(anchor channels HAC-C-P 40/22 and HAC-P 40L with notching channel bolts HBC 40/22-N; anchor channels HAC-C-P 50/30 and HAC-C-P 50L with notching channel bolts HBC 50/30-N and serrated anchor channels HAC-C-T with serrated channel bolts HBC-T)
- Fatigue cyclic tension loads
(anchor channels and channel bolts according to Annex C17)
- Seismic tension, seismic shear perpendicular to the longitudinal axis of the channel and shear in the direction of the longitudinal axis of the channel (seismic performance category C1)
(anchor channels with channel bolts according to Annex C19);
- Fire exposure only for concrete class C20/25 to C50/60 for tension and shear perpendicular to the longitudinal axis of the channel
(anchor channels and channel bolts according to Annexes C23-C25)

Base materials:

- Reinforced or unreinforced compacted normal weight concrete without fibers according to EN 206.
- Strength classes C12/15 to C90/105 according to EN 206.
- Cracked or uncracked concrete.

Use conditions (Environmental conditions):

- Structures subject to dry internal conditions
(anchor channels and channel bolts according to Annex A8, Table 5, column 2 and 3).
- Structures subject to internal conditions with usual humidity (e.g. kitchen, bath and laundry in residential buildings, exceptional permanent damp conditions and application under water)
(anchor channels and channel bolts according to Annex A8, Table 5, column 2c and 3).
- According to EN 1993-1-4 relating to corrosion resistance class CRC II
(anchor channels and channel bolts made of stainless-steel number 1.4301, washers and nuts made of stainless-steel number 1.4401, 1.4404, 1.4571, 1.4362 and 1.4578 according to Annex A8, Table 5, column 3).
- According to EN 1993-1-4 relating to corrosion resistance class CRC III
(anchor channels and channel bolts, washers and nuts made of stainless-steel number 1.4401, 1.4404, 1.4571, 1.4362 and 1.4578 according to Annex A8, Table 5, column 4).

Hilti anchor channels (HAC-C) with channel bolts (HBC)

**Intended Use
Specifications**

Annex B1

Design:

- Anchor channels are designed under the responsibility of an engineer experienced in anchorages and concrete work.
- Verifiable calculation notes and drawings are prepared taking account of the loads to be anchored. The position of the anchor channel and channel bolts are indicated on the design drawings (e.g. position of the anchor channel relative to the reinforcement or to supports).
- For static and quasi-static loading and fire exposure the anchor channels are designed in accordance with EN 1992-4 and EOTA TR 047.
- For fatigue loading the anchor channels are designed in accordance with TR 050.
- The characteristic resistances are calculated with the minimum effective embedment depth.

Installation:

- The installation of anchor channels is carried out by appropriately qualified personnel under the supervision of the person responsible for the technical matters on site.
- Use of the anchor channels only as supplied by the manufacturer - without any manipulations, repositioning or exchanging of channel components.
- Cutting of anchor channels is allowed only if pieces according to Annex B3, Table 6 and 7 as well as Annex B4, Table 8 are generated including end-spacing and minimum channel length and only to be used in dry internal conditions.
- Installation in accordance with the installation instructions given in Annexes B7-B11.
- The anchor channels are fixed on the formwork, reinforcement or auxiliary construction such that no movement of the channels will occur during the time of laying the reinforcement and of placing and compacting the concrete.
- The concrete under the head of the anchors is properly compacted. The channels are protected from penetration of concrete into the internal space of the channels.
- Washer may be chosen according to Annex A6 and provided separately by the user.
- Orientating the channel bolt (groove according to Annex B8, B9 and B10) rectangular to the channel axis.
- Hexagonal nut must be fastened by a calibrated torque wrench. The required installation torques given in Annex B5 must be applied and must not be exceeded.

Hilti anchor channels (HAC-C) with channel bolts (HBC)	Annex B2
Intended Use Specifications	

Table 6: Installation parameters for HAC-C-T (hot-rolled serrated) anchor channels

Anchor channel			HAC-C-T 29/20			HAC-C-T 40/22		HAC-C-T 40L	HAC-C-T 50/30	HAC-C-T 50L	HAC-C-T 53/34
Minimum effective embedment depth	$h_{ef,min}$	[mm]	82			94		110	108	148	155
Minimum spacing	s_{min}		100	100	50	80	100	80	80	80	80
Maximum spacing	s_{max}		200			250		250		250	
End spacing	x		25 ²⁾			25 ²⁾		30 ²⁾		35	
Minimum channel length	l_{min}		150	150	100	130	150	130	140	140	170
Minimum edge distance	c_{min}		75	50	75	75	50	75	75	75	75
Minimum thickness of concrete member	h_{min}		100	125	125	100	125	125	120	162	178
$h_{ef} + t_h + c_{nom}$ ¹⁾											

¹⁾ c_{nom} according to EN 1992-1-1

²⁾ the end spacing may be increased from 25 mm to 35 mm

Table 7: Installation parameters for HAC-C(-P) (hot-rolled) anchor channels

Anchor channel			HAC-C 40/22	HAC-C-P 40/22	HAC-C-P 40L	HAC-C 50/30	HAC-C-P 50/30	HAC-C-P 50L	HAC-C 52/34	
Minimum effective embedment depth	$h_{ef,min}$	[mm]	79	91	106	94	106	148	155	
Minimum spacing	s_{min}		100	50	50	100	50 ³⁾	50	100	
Maximum spacing	s_{max}		250							
End spacing	x		25 ²⁾							35 ⁴⁾
Minimum channel length	l_{min}		150	100	100	150	100	100	170 ⁵⁾	
Minimum edge distance	c_{min}		50			75			75	
Minimum thickness of concrete member	h_{min}		100	100	120	105	120	162	165	
$h_{ef} + t_h + c_{nom}$ ¹⁾										

¹⁾ c_{nom} according to EN 1992-1-1

²⁾ the end spacing may be increased from 25 mm to 35 mm

³⁾ $s_{min} = 100$ mm when used in combination with notching bolts

⁴⁾ $x = 25$ mm for welded I-anchors

⁵⁾ $l_{min} = 150$ mm for welded I-anchors

Hilti anchor channels (HAC-C) with channel bolts (HBC)

Intended Use

Installation parameters for anchor channels (HAC-C) and channel bolts (HBC)

Annex B3

Table 8: Installation parameters for HAC-C (cold-formed) anchor channels

Anchor channel			HAC-C 28/15	HAC-C 38/17	HAC-C 40/25	HAC-C 49/30	HAC-C 54/33
Minimum effective embedment depth	$h_{ef,min}$	[mm]	45	76	79	94	155
Minimum spacing	s_{min}		50	100			
Maximum spacing	s_{max}		200		250		
End spacing	x		25 ²⁾				
Minimum channel length	l_{min}		100	150			
Minimum edge distance	c_{min}		40	50	50	75	100
Minimum thickness of concrete member	h_{min}		70	100	100	120	180
		$h_{ef} + t_h + c_{nom}$ ¹⁾					

¹⁾ c_{nom} according to EN 1992-1-1

²⁾ the end spacing may be increased from 25 mm to 35 mm

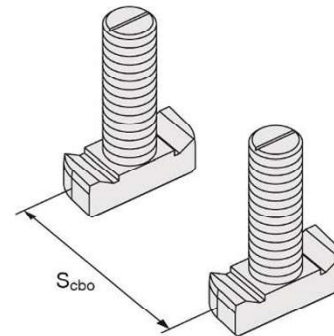
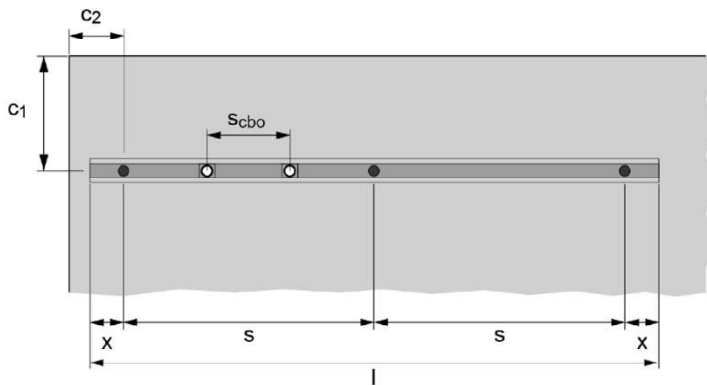

Table 9: Minimum spacing for channel bolts

Channel bolt			M8	M10	M12	M16	M20
Minimum spacing between channel bolts	$s_{cbo,min}$	[mm]	40	50	60	80	100

s_{cbo} = center to center spacing between channel bolts ($s_{cbo,min} = 5d$)

Hilti anchor channels (HAC-C) with channel bolts (HBC)

Intended Use

Installation parameters for anchor channels (HAC-C) and channel bolts (HBC)

Annex B4

Table 10: Required installation torque T_{inst}

Channel bolt		Installation torque T_{inst} [Nm] ¹⁾		
		General $T_{inst,g}$ [Nm]	Steel - steel contact $T_{inst,s}$ [Nm]	
		8.8, A4-70	8.8	A4-70
Bolts for hot-rolled serrated (HAC-C-T) anchor channels ²⁾				
HBC-T 29/20	M10	40	40	40
	M12	60	60	60
HBC-T 40/22	M10	40	40	40
	M12	60	60	60
	M16	100	100	100
HBC-T 50/30	M16	100	100	100
	M20	120	120	120
Bolts for hot-rolled and/or cold-formed smooth (HAC-C) anchor channels ²⁾				
HBC 40/22	M10	15	- ³⁾	22
	M12	25	45	50
	M16	30	100	90
HBC 40/22-N	M16	30	160	- ³⁾
HBC 50/30	M12	25	45	50
	M16	60	100	130
	M20	75	360	250
HBC 50/30-N	M16	60	185	- ³⁾
	M20	75	320	- ³⁾
Bolts for cold-formed smooth (HAC-C) anchor channels ²⁾				
HBC 28/15	M8	7	20	15
	M10	10	40	30
	M12	13	60	50
HBC 38/17	M10	15	- ³⁾	22
	M12	25	45	50
	M16	40	100	90

¹⁾ T_{inst} must not be exceeded

²⁾ According to the Table 3

³⁾ Product not available

Anchor channels (HAC-C) with channel bolts (HBC)

Intended Use
Installation parameters for channel bolts (HBC)

Annex B5

General: The fixture is in contact with the channel profile and the concrete surface

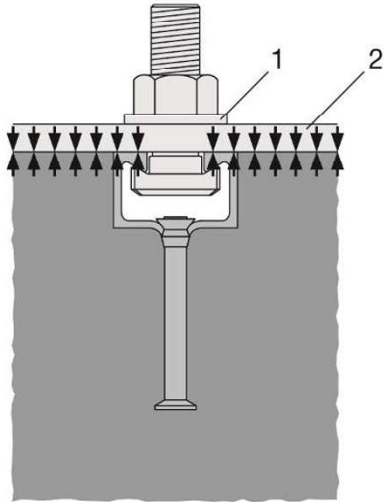

Steel-steel contact: The fixture is fastened to the anchor channel by suitable steel part (e.g. washer). Fixture is in contact with the channel profile only.

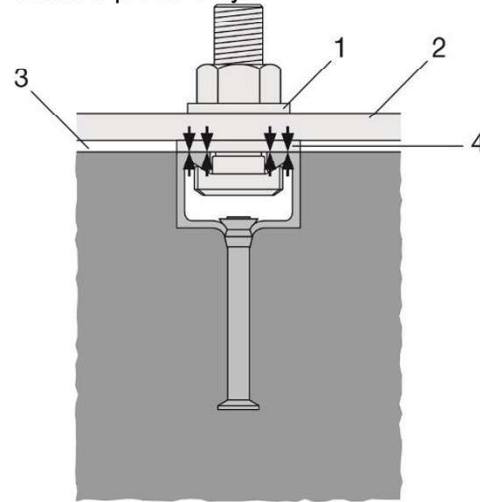

Key

- 1 washer
- 2 fixture
- 3 gap
- 4 suitable steel part

Anchor channels (HAC-C) with channel bolts (HBC)

Intended Use
Position of the fixture

Annex B6

HAC-C(-P)

2443751-11.2024

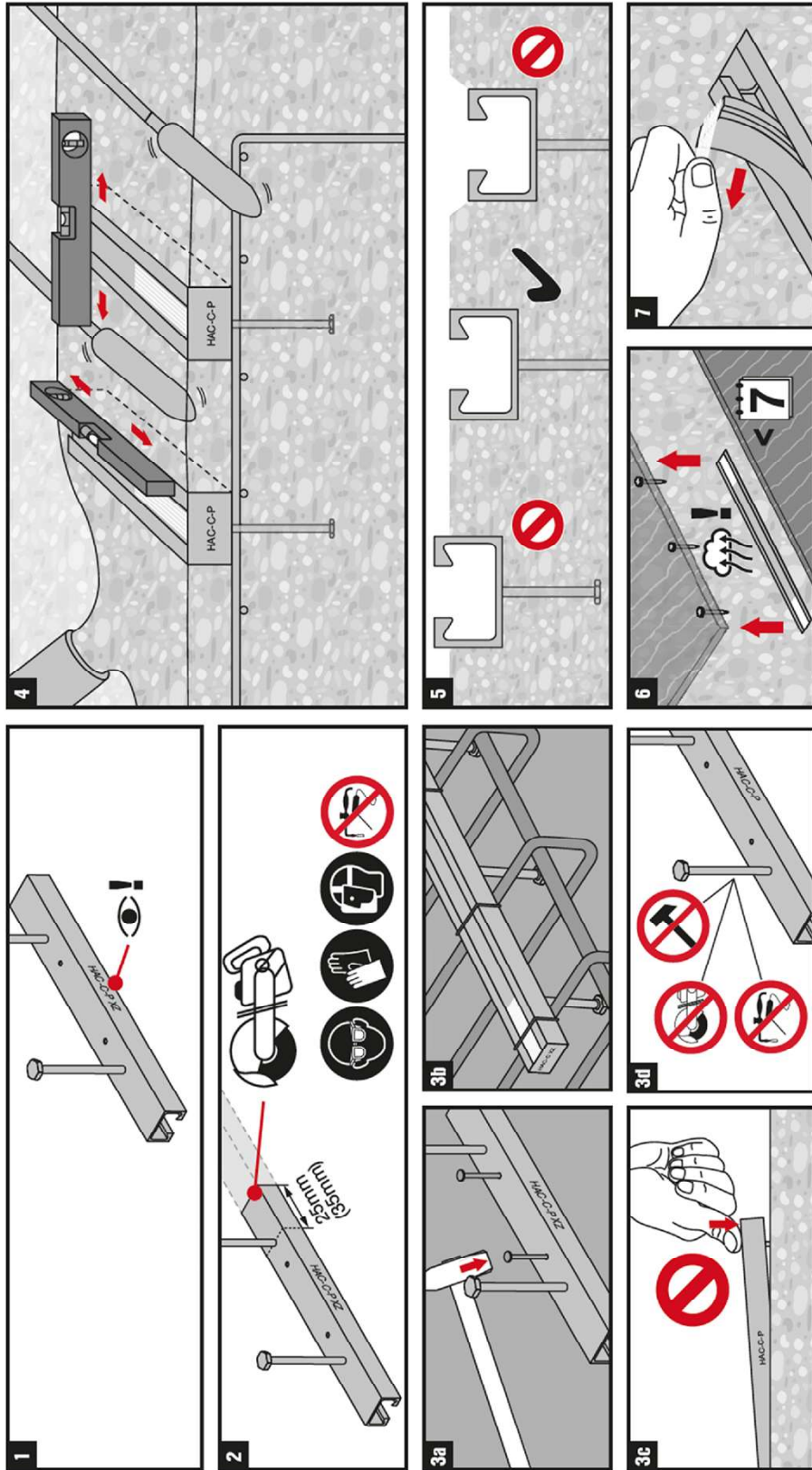

Hilti anchor channels (HAC-C) with channel bolts (HBC)

Intended Use
Installation instructions for anchor channels (HAC-C)

Annex B7



HAC-C-T



2412857-04_2025

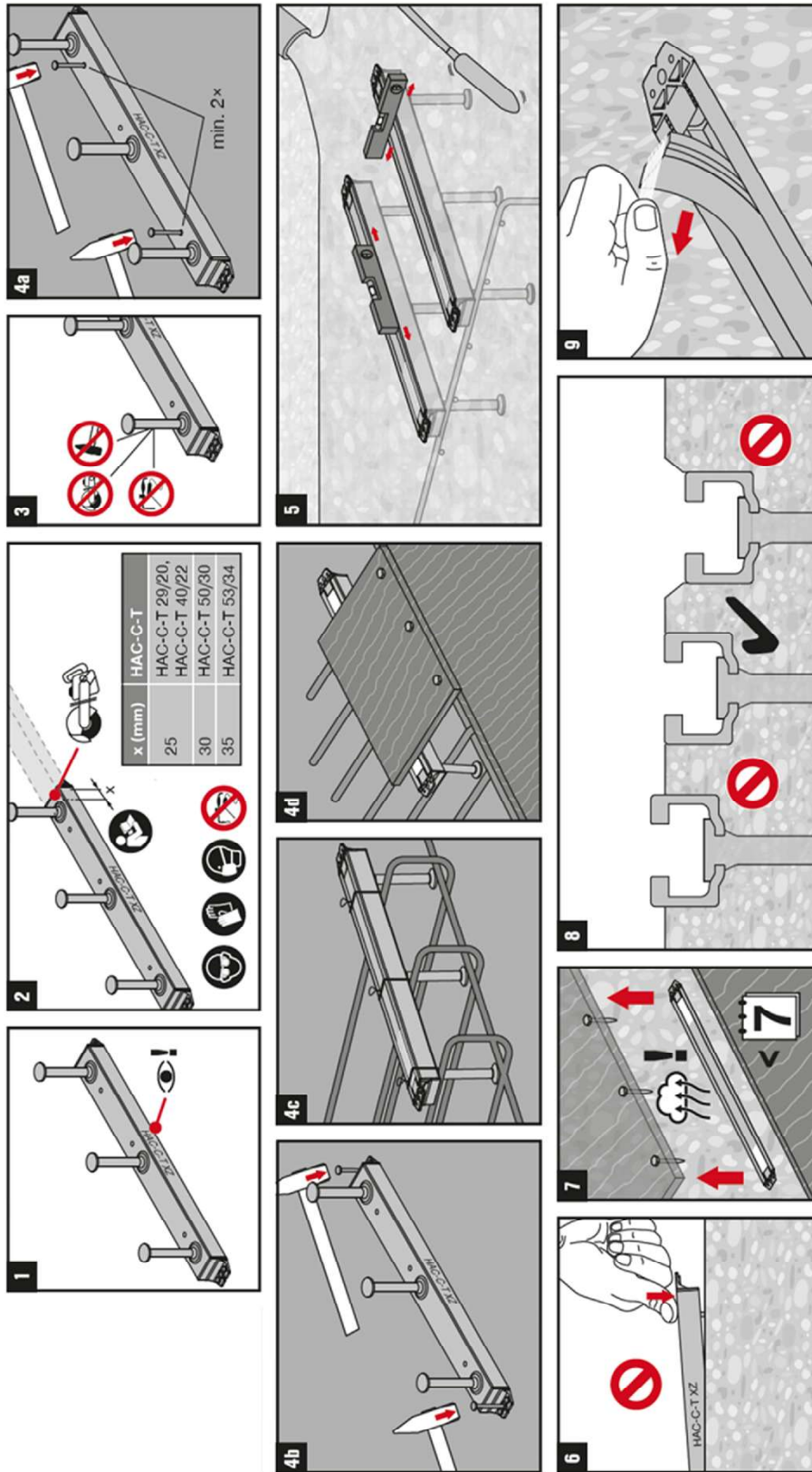

Hilti anchor channels (HAC-C) with channel bolts (HBC)

Intended Use
Installation instructions for anchor channels (HAC-C-T)

Annex B8



2194125-09.2022

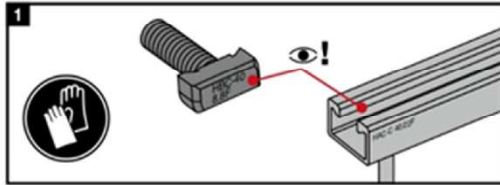

HBC-28/15	HAC-C 28/15
HBC-38/17	HAC-C 38/17
HBC-40/22	HAC-C-P 40/22, HAC-C-P 40L, HAC-C 40/22, HAC-C 40/25
HBC-50/30	HAC-C-P 50/30, HAC-C-P 50L, HAC-C 49/30, HAC-C 50/30
HBC-52/34	HAC-C 52/34, HAC-C 54/33
	HAC-HW53, HAC-C 52/34

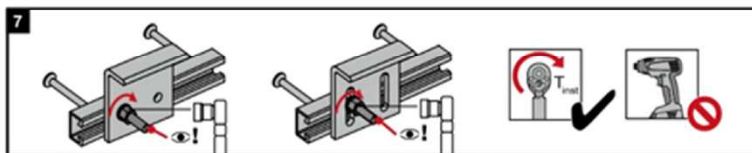
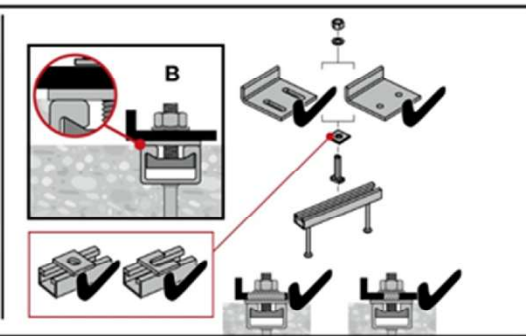
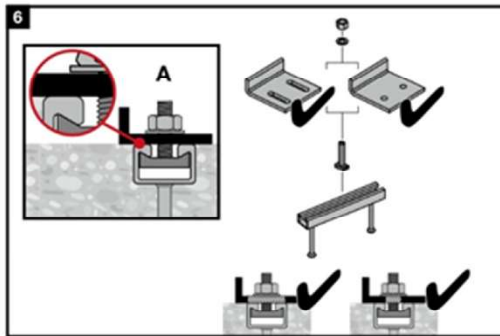
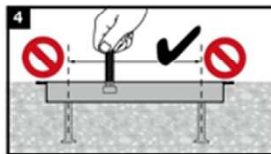
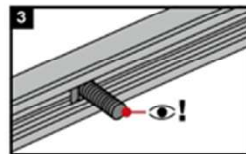
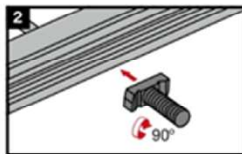

Channel bolt		T _{inst} [Nm]			
		A		B	
		8.8, A4-70	8.8	8.8	A4-70
HBC-28/15	M8	7	20	-	15
	M10	10	40	-	30
	M12	13	60	-	50
HBC-38/17	M10	15	15	-	22
	M12	25	45	-	50
	M16	40	100	-	90
HBC-40/22	M10	15	15	-	22
	M12	25	45	-	50
	M16	30	100	-	90
HBC-50/30	M12	25	45	-	50
	M16	55	100	-	130
	M20	55	360	-	250
HBC-52/34	M20	55	360	-	-

T_{inst} is the installation torque that shall be applied with a torque wrench and must not be exceeded.

Hilti anchor channels (HAC-C) with channel bolts (HBC)

Intended Use
Installation instructions for channel bolts (HBC)

Annex B9



HBC-N

2257118-09.2022

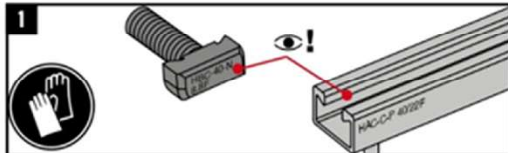

HBC-40/22-N	HAC-C 40/22, HAC-C-P 40/22, HAC-C-P 40L	
HBC-50/30-N	HAC-C 50/30, HAC-C-P 50/30, HAC-C-P 50L, HAC-C 52/34	

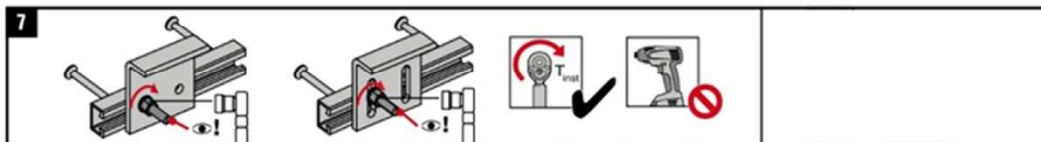
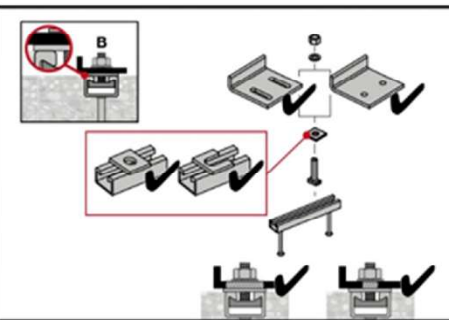
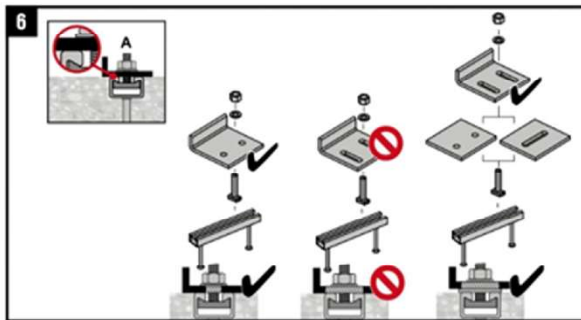
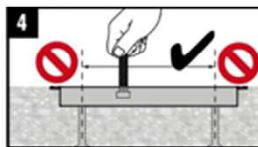
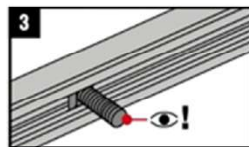
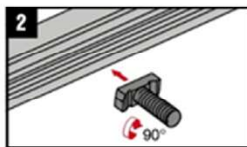

Anchor Channel	Channel Bolt	T _{inst} [Nm]	
HAC-C-P 40/22	HBC-40/22-N M16	8.8	8.8
HAC-C-P 40L		160	160
HAC-C 40/22		60	160
HAC-C-P 50/30	HBC-50/30-N M16	185	185
HAC-C-P 50L		185	185
HAC-C 50/30		185	185
HAC-C 52/34	HBC-50/30-N M20	320	320
HAC-C-P 50/30		320	320
HAC-C-P 50L		320	320
HAC-C 50/30			
HAC-C 52/34			

T_{inst} is the installation torque that shall be applied with a torque wrench and must not be exceeded.

Hilti anchor channels (HAC-C) with channel bolts (HBC)

Intended Use
Installation instructions for notching channel bolts (HBC-N)

Annex B10



HBC-T



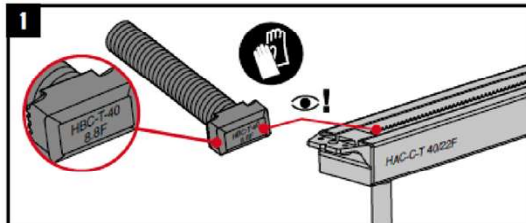

2412973-05.2025

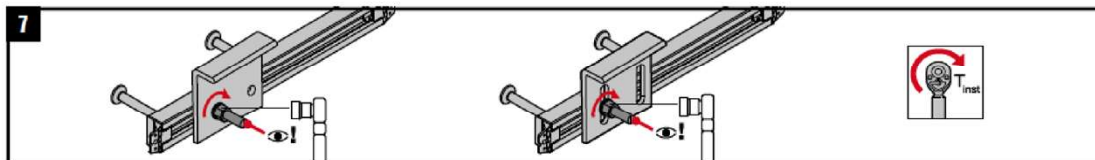
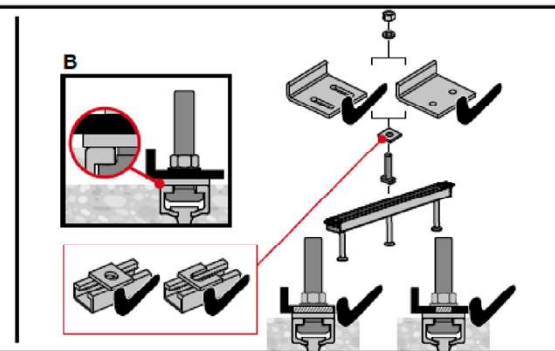
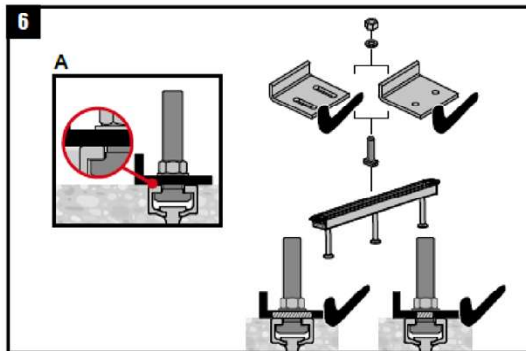
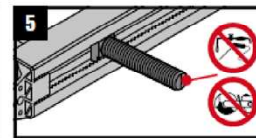
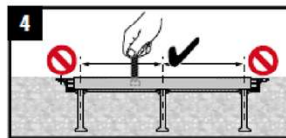
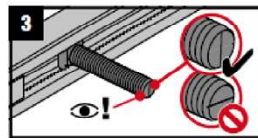
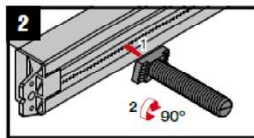

T-bolt	Channel
HBC-T-29/20	HAC-C-T 29/20
HBC-T-40/22	HAC-C-T 40/22
HBC-T-50/30	HAC-C-T 50/30
	HAC-C-T 53/34



Channel bolt		 	
		T_{inst} [Nm] 	
		8.8 / A4-70	
HBC-T-29/20	M10	40	
	M12	60	
HBC-T-40/22	M10	40	
	M12	60	
	M16	100	
HBC-T-50/30	M16	100	
	M20	120	

T_{inst} is the installation torque that shall be applied with a torque wrench and must not be exceeded

Hilti anchor channels (HAC-C) with channel bolts (HBC)

Intended Use
Installation instructions for serrated channel bolts (HBC-T)

Annex B11

Table 11: Characteristic resistances under tension load – steel failure of HAC-C-T (serrated hot-rolled) anchor channels

Anchor channel				HAC-C-T 29/20	HAC-C-T 40/22	HAC-C-T 40L	HAC-C-T 50/30	HAC-C-T 50L	HAC-C-T 53/34
Steel failure: Anchor									
Characteristic resistance	Carbon steel	$N_{Rk,s,a}$	[kN]	35,0	41,0		57,0	73,5	
	Stainless steel				45,0				
Partial factor		γ_{Ms} ¹⁾	[-]	1,8					
Steel failure: Connection between anchor and channel									
Characteristic resistance	Carbon steel	$N_{Rk,s,c}$	[kN]	33,0	40,0	55,0		73,5	
	Stainless steel			35,0	42,0	60,0			
Partial factor		$\gamma_{Ms,ca}$ ¹⁾	[-]	1,8					
Steel failure: Local flexure of channel lips									
Characteristic spacing of channel bolts for $N_{Rk,s,l}$		$s_{l,N}$	[mm]	61	76	100		107	
Characteristic resistance	Carbon steel	$N^0_{Rk,s,l}$	[kN]	35,0	45,0		64,0		85,0
	Stainless steel				42,0				
Partial factor		$\gamma_{Ms,l}$ ¹⁾	[-]	1,8					

¹⁾ In absence of other national regulations.

Table 12: Characteristic resistances under tension load – steel failure of HAC-C-P (smooth hot-rolled) anchor channels

Anchor channel				HAC-C 40/22	HAC-C-P 40/22	HAC-C-P 40L	HAC-C 50/30	HAC-C-P 50/30	HAC-C-P 50L	HAC-C 52/34
Steel failure: Anchor										
Characteristic resistance		$N_{Rk,s,a}$	[kN]	20,0	40,0	40,0	31,0	57,0	57,0	55,0
Partial factor		γ_{Ms} ¹⁾	[-]	1,8						
Steel failure: Connection between anchor and channel										
Characteristic resistance		$N_{Rk,s,c}$	[kN]	20,0	39,6	39,6	31,0	50,6	50,6	55
Partial factor		$\gamma_{Ms,ca}$ ¹⁾	[-]	1,8						
Steel failure: Local flexure of channel lips										
Characteristic spacing of channel bolts for $N_{Rk,s,l}$		$s_{l,N}$	[mm]	79	79	79	98	98	98	105
Characteristic resistance		$N^0_{Rk,s,l}$	[kN]	47,9	47,9	47,9	50,5	50,5	50,5	65,0
Partial factor		$\gamma_{Ms,l}$ ¹⁾	[-]	1,8						

¹⁾ In absence of other national regulations.

Hilti anchor channels (HAC-C) with channel bolts (HBC)

Performance

Characteristic resistances of anchor channels (HAC-C) under tension load – steel failure

Annex C1

Table 13: Characteristic resistances under tension load – steel failure of HAC-C (cold-formed) anchor channels

Anchor channel			HAC-C 28/15	HAC-C 38/17	HAC-C 40/25	HAC-C 49/30	HAC-C 54/33
Steel failure: Failure of anchor							
Characteristic resistance	$N_{Rk,s,a}$	[kN]	9,0	18,0	20,0	31,0	55,0
Partial safety factor	γ_{Ms} ¹⁾	[-]	1,8				
Steel failure: Failure of connection between anchor and channel							
Characteristic resistance	$N_{Rk,s,c}$	[kN]	9,0	18,0	20,0	31,0	55,0
Partial safety factor	$\gamma_{Ms,ca}$ ¹⁾	[-]	1,8				
Steel failure: Local failure by flexure of channel lips							
Characteristic spacing of channel bolts for $N_{Rk,s,l}$	$s_{l,N}$	[mm]	56	76	80	100	107
Characteristic resistance	$N^0_{Rk,s,l}$	[kN]	9,0	18,0	20,0	31,0	55,0
Partial safety factor	$\gamma_{Ms,l}$ ¹⁾	[-]	1,8				

¹⁾ In absence of other national regulations.

Hilti anchor channels (HAC-C) with channel bolts (HBC)

Performance

Characteristic resistances of anchor channels (HAC-C) under tension load – steel failure

Annex C2

Table 14: Characteristic flexural resistance of HAC-C-T (serrated hot-rolled) channels under tension load

Anchor channel				HAC-C-T 29/20	HAC-C-T 40/22	HAC-C-T 40 L	HAC-C-T 50/30	HAC-C-T 50L	HAC-C-T 53/34
Steel failure: Failure by flexure of channel									
Characteristic flexural resistance of channel	Carbon steel	$M_{Rk,s,flex}$	[Nm]	977	1557		3256		4870
	Stainless steel			1100	1754		3366		4626
Partial factor		$\gamma_{Ms,flex}^{1)}$	[-]	1,15					

¹⁾ In absence of other national regulations.

Table 15: Characteristic flexural resistance of HAC-C(-P) (hot-rolled) channels under tension load

Anchor channel				HAC-C 40/22	HAC-C-P 40/22	HAC-C-P 40L	HAC-C 50/30	HAC-C-P 50/30	HAC-C-P 50L	HAC-C 52/34
Steel failure: Failure by flexure of channel										
Characteristic flexural resistance of channel	Carbon steel	$M_{Rk,s,flex}$	[Nm]	1013	1704	1704	2084	3448	3448	3435
	Stainless steel									
Partial factor		$\gamma_{Ms,flex}^{1)}$	[-]	1,15						

¹⁾ In absence of other national regulations.

Table 16: Characteristic flexural resistance of HAC-C (cold-formed) channels under tension load

Anchor channel				HAC-C 28/15	HAC-C 38/17	HAC-C 40/25	HAC-C 49/30	HAC-C 54/33
Steel failure: Failure by flexure of channel								
Characteristic flexural resistance of channel	Carbon steel	$M_{Rk,s,flex}$	[Nm]	316	538	979	1669	2929
	Stainless steel				527		1702	2832
Partial factor		$\gamma_{Ms,flex}^{1)}$	[-]	1,15				

¹⁾ In absence of other national regulations.

Hilti anchor channels (HAC-C) with channel bolts (HBC)

Performance

Characteristic resistances of anchor channels (HAC-C) under tension load – steel failure

Annex C3

Table 17: Characteristic resistances under tension load – concrete failure of HAC-C-T (serrated hot-rolled) anchor channels

Anchor channel				HAC-C-T 29/20	HAC-C-T 40/22	HAC-C-T 40L	HAC-C-T 50/30	HAC-C-T 50L	HAC-C-T 53/34
Type of anchor ²⁾				R	R	R	R	R	R
Concrete failure: Pull-out									
Characteristic resistance in cracked concrete C12/15		$N_{Rk,p}$	[kN]	17,2	25,6		39,2		37,6
Characteristic resistance in uncracked concrete C12/15				24,0	35,8		54,9		52,6
Factor for $N_{Rk,p} = N_{Rk,p(C12/15)} \cdot \Psi_c$	C16/20	Ψ_c	[-]	1,33					
	C20/25			1,67					
	C25/30			2,08					
	C30/37			2,50					
	C35/45			2,92					
	C40/50			3,33					
	C45/55			3,75					
	C50/60			4,17					
	C55/67			4,58					
$\geq C60/75$	5,00								
Partial factor		$\gamma_{Mp} =$ $\gamma_{Mc}^{1)}$	[-]	1,5					
Concrete failure: Concrete cone									
Product factor k_1	Cracked concrete	$k_{cr,N}$	[-]	7,9	8,1	8,3	8,2	8,6	8,7
	Uncracked concrete	$k_{ucr,N}$	[-]	11,3	11,5	11,8	11,8	12,3	12,4
Partial factor		$\gamma_{Mc}^{1)}$	[-]	1,5					
Concrete failure: Splitting									
Characteristic edge distance		$c_{cr,sp}$	[mm]	246	282	330	324	444	465
Characteristic spacing		$s_{cr,sp}$	[mm]	492	564	660	648	888	930
Partial factor		$\gamma_{Msp} =$ $\gamma_{Mc}^{1)}$	[-]	1,5					

¹⁾ In absence of other national regulations

²⁾ Type of anchor according Annexes A3 and A6

Hilti anchor channels (HAC-C) with channel bolts (HBC)

Performance

Characteristic resistances of anchor channels (HAC-C) under tension load – concrete failure

Annex C4

Table 18: Characteristic resistances under tension load – concrete failure of HAC-C-(P) (hot-rolled) anchor channels

Anchor channel			HAC-C 40/22		HAC-C-P 40/22		HAC-C-P 40L		HAC-C 50/30		HAC-C-P 50/30		HAC-C-P 50L		HAC-C 52/34	
			I	R	I	R	I	R	I	R	I	R	I	R	I	R
Type of anchor ³⁾																
Concrete failure: Pull-out																
Characteristic resistance in cracked concrete C12/15	$N_{Rk,p}$	[kN]	27,0	13,6	34,2	25,6	- ¹⁾	25,6	33,8	21,2	42,8	39,2	- ¹⁾	39,2	68,4	33,2
			37,8	19,0	47,9	35,8	- ¹⁾	35,8	47,3	29,7	59,9	54,9	- ¹⁾	54,9	95,8	46,5
Factor for $N_{Rk,p} = N_{Rk,p(C12/15)} \cdot \Psi_c$	Ψ_c	[-]	C16/20													
			C20/25													
			C25/30													
			C30/37													
			C35/45													
			C40/50													
			C45/55													
			C50/60													
			C55/67													
			≥C60/75													
Partial factor		$\gamma_{Mp} = \gamma_{Mc}^{2)}$	[-]		1,5											
Concrete failure: Concrete cone																
Product factor k_1	Cracked concrete	$k_{cr,N}$	[-]		7,9	8,0	8,2	8,1	8,2	8,6	8,7					
	Uncracked concrete	$k_{ucr,N}$	[-]		11,2	11,5	11,7	11,6	11,7	12,3	12,4					
Partial factor		$\gamma_{Mc}^{2)}$	[-]		1,5											
Concrete failure: Splitting																
Characteristic edge distance	$c_{cr,sp}$	[mm]	237	273	318	282	318	444	465							
Characteristic spacing	$s_{cr,sp}$	[mm]	474	546	636	564	636	888	930							
Partial factor		$\gamma_{Mp} = \gamma_{Mc}^{2)}$	[-]		1,5											

¹⁾ Product not available

²⁾ In absence of other national regulations

³⁾ Type of anchor according Annexes A3 and A6

Hilti anchor channels (HAC-C) with channel bolts (HBC)

Performance

Characteristic resistances of anchor channels (HAC-C) under tension load – concrete failure

Annex C5

Table 19: Characteristic resistances under tension load – concrete failure of HAC-C (cold-formed) anchor channels

Anchor channel			HAC-C 28/15	HAC-C 38/17	HAC-C 40/25	HAC-C 49/30	HAC-C 54/33	
Type of anchor ²⁾			R	R	R	R	R	
Concrete failure: Pull-out								
Characteristic resistance in cracked concrete C12/15		N _{Rk,p} [kN]	7,6	13,6	13,6	21,2	33,2	
Characteristic resistance in uncracked concrete C12/15			10,7	19,0	19,0	29,7	46,5	
Factor for N _{Rk,p} = N _{Rk,p(C12/15)} · Ψ _c	C16/20	Ψ _c	[-]	1,33				
	C20/25			1,67				
	C25/30			2,08				
	C30/37			2,50				
	C35/45			2,92				
	C40/50			3,33				
	C45/55			3,75				
	C50/60			4,17				
	C55/67			4,58				
≥C60/75	5,00							
Partial factor		$\gamma_{Mp} = \gamma_{Mc}^{1)}$	[-]	1,5				
Concrete failure: Concrete cone								
Product factor k ₁	cracked concrete	k _{cr,N}	[-]	7,2	7,8	7,9	8,1	8,7
	uncracked concrete	k _{ucr,N}	[-]	10,3	11,2	11,2	11,6	12,4
Partial factor		$\gamma_{Mc}^{1)}$	[-]	1,5]				
Concrete failure: Splitting								
Characteristic edge distance		c _{cr,sp}	[mm]	135	228	237	282	465
Characteristic spacing		s _{cr,sp}	[mm]	270	456	474	564	930
Partial factor		$\gamma_{Msp} = \gamma_{Mc}^{1)}$	[-]	1,5				

¹⁾ In absence of other national regulations;

²⁾ Type of anchor according Annexes A3 and A6

Hilti anchor channels (HAC-C) with channel bolts (HBC)

Performance

Characteristic resistances of anchor channels (HAC-C) under tension load – concrete failure

Annex C6

Table 20: Displacements of HAC-C-T (hot-rolled serrated) anchor channels under tension load

Anchor channel				HAC-C-T 29/20	HAC-C-T 40/22	HAC-C-T 40L	HAC-C-T 50/30	HAC-C-T 50L	HAC-C-T 53/34
Tension load	Carbon steel	N	[kN]	14,8	20,1	20,1	34,6	34,6	50,8
	Stainless steel			17,3	21,0	21,0	37,3	37,3	50,2
Short-term displacement ¹⁾	Carbon steel	δ_{N0}	[mm]	0,9	1,5	1,5	1,2	1,2	1,8
	Stainless steel			0,9	1,5	1,5	1,7	1,7	1,6
Long-term displacement ¹⁾	Carbon steel	$\delta_{N\infty}$	[mm]	1,8	3,0	3,0	2,4	2,4	3,6
	Stainless steel			1,8	3,0	3,0	3,4	3,4	3,2

¹⁾ Displacements in midspan of the anchor channel, including slip of channel bolt, deformation of channel lips, bending of the channel and slip of the anchor channel in concrete

Table 21: Displacements of HAC-C-P (hot-rolled) anchor channels under tension load

Anchor channel				HAC-C 40/22	HAC-C-P 40/22	HAC-C-P 40L	HAC-C 50/30	HAC-C-P 50/30	HAC-C-P 50L	HAC-C 52/34
Tension load	N	[kN]		13,9	15,3	15,3	14,3	25,8	25,8	25,8
Short-term displacement ¹⁾	δ_{N0}	[mm]		2,3	1,1	1,1	2,2	1,4	1,4	1,4
Long-term displacement ¹⁾	$\delta_{N\infty}$	[mm]		4,6	2,2	2,2	4,4	2,8	2,8	2,8

¹⁾ Displacements in midspan of the anchor channel, including slip of channel bolt, deformation of channel lips, bending of the channel and slip of the anchor channel in concrete.

Table 22: Displacements of HAC-C (cold-formed) anchor channels under tension load

Anchor channel				HAC-C 28/15	HAC-C 38/17	HAC-C 40/25	HAC-C 49/30	HAC-C 54/33
Tension load	N	[kN]		3,6	7,1	7,9	12,3	21,8
Short-term displacement ¹⁾	δ_{N0}	[mm]		0,6	1,3	1,4	1,4	1,6
Long-term displacement ¹⁾	$\delta_{N\infty}$	[mm]		1,2	2,6	2,8	2,8	3,2

¹⁾ Displacements in midspan of the anchor channel, including slip of channel bolt, deformation of channel lips, bending of the channel and slip of the anchor channel in concrete.

Hilti anchor channels (HAC-C) with channel bolts (HBC)

Performance
Displacements under tension load

Annex C7

Table 23: Characteristic resistances under shear load – steel failure of HAC-C-T (hot-rolled serrated) anchor channels

Anchor channel				HAC-C-T 29/20	HAC-C-T 40/22	HAC-C-T 40L	HAC-C-T 50/30	HAC-C-T 50L	HAC-C-T 53/34
Steel failure: Anchor									
Characteristic resistance	Carbon steel	$V_{Rk,s,a,y}$	[kN]	37,0	52,0		80,0		120,0
	Stainless steel				49,5		100,0		
Characteristic resistance	Carbon steel	$V_{Rk,s,a,x}$	[kN]	22,9	24,7		37,1		44,1
	Stainless steel				28,3				
Partial factor	Carbon steel	$\gamma_{Ms}^{1)}$	[-]	1,5					
	Stainless steel								
Steel failure: Connection between anchor and channel									
Characteristic resistance	Carbon steel	$V_{Rk,s,c,y}$	[kN]	37,0	52,0		80,0		120,0
	Stainless steel				49,5		100,0		
Characteristic resistance	Carbon steel	$V_{Rk,s,c,x}$	[kN]	19,8	24,0		33,0		44,1
	Stainless steel				21,0		25,2		
Partial factor		$\gamma_{Ms}^{1)}$	[-]	1,8					
Steel failure: Local flexure of channel lips under shear load perpendicular to the longitudinal axis of the channel									
Characteristic spacing of channel bolts for $V_{Rk,s,l}$		$s_{l,v}$	[mm]	61,0	76,0		100,0		107,0
Characteristic resistance	Carbon steel	$V^0_{Rk,s,l,y}$	[kN]	37,0	52,0		80,0		120,0
	Stainless steel				49,5		100,0		
Partial factor		$\gamma_{Ms,l}^{1)}$	[-]	1,8					

¹⁾ In absence of other national regulations

Hilti anchor channels (HAC-C) with channel bolts (HBC)

Performance

Characteristic resistances of anchor channels (HAC-C) under shear load – steel failure

Annex C8

Table 24: Characteristic resistances under shear load – steel failure of HAC-C-(P) (hot-rolled) anchor channels

Anchor channel			HAC-C 40/22	HAC-C-P 40/22	HAC-C-P 40L	HAC-C 50/30	HAC-C-P 50/30	HAC-C-P 50L	HAC-C 52/34
Steel failure: Anchor									
Characteristic resistance	$V_{Rk,s,a,y}$	[kN]	26,0	58,1	58,1	40,3	100,0	100,0	121,5
Characteristic resistance	$V_{Rk,s,a,x}$	[kN]	- ²⁾	24,0	24,0	- ²⁾	34,2	34,2	33,1
Partial factor	γ_{Ms} ¹⁾	[-]	1,5						
Steel failure: Connection between anchor and channel									
Characteristic resistance	$V_{Rk,s,c,y}$	[kN]	26,0	58,1	58,1	40,3	100,0	100,0	121,5
Characteristic resistance	$V_{Rk,s,c,x}$	[kN]	- ²⁾	23,8	23,8	- ²⁾	30,4	30,4	28,1
Partial factor	$\gamma_{Ms,ca}$ ¹⁾	[-]	1,8						
Steel failure: Local flexure of channel lips under shear load perpendicular to the longitudinal axis of the channel									
Characteristic spacing of channel bolts for $V_{Rk,s,l}$	$s_{l,v}$	[mm]	80	80	80	99	99	99	105
Characteristic resistance	$V^0_{Rk,s,l,y}$	[kN]	55,0	55,0	55,0	91,7	91,7	91,7	71,5
Partial factor	$\gamma_{Ms,l}$ ¹⁾	[-]	1,8						

¹⁾ In absence of other national regulations

²⁾ No performance assessed

Table 25: Characteristic resistances under shear load – steel failure of HAC-C (cold-formed) anchor channels

Anchor channel			HAC-C 28/15	HAC-C 38/17	HAC-C 40/25	HAC-C 49/30	HAC-C 54/33
Steel failure: Anchor							
Characteristic resistance	$V_{Rk,s,a,y}$	[kN]	9,0	18,0	20,0	31,0	55,0
Partial factor	γ_{Ms} ¹⁾	[-]	1,5				
Steel failure: Connection between anchor and channel							
Characteristic resistance	$V_{Rk,s,c,y}$	[kN]	9,0	18,0	20,0	31,0	55,0
Partial factor	$\gamma_{Ms,ca}$ ¹⁾	[-]	1,8				
Steel failure: Local flexure of channel lips under shear load perpendicular to the longitudinal axis of the channel							
Characteristic spacing of channel bolts for $V_{Rk,s,l}$	$s_{l,v}$	[mm]	56	76	80	100	107
Characteristic resistance	$V^0_{Rk,s,l,y}$	[kN]	9,0	18,0	20,0	31,0	55,0
Partial factor	$\gamma_{Ms,l}$ ¹⁾	[-]	1,8				

¹⁾ In absence of other national regulations.

Hilti anchor channels (HAC-C) with channel bolts (HBC)

Performance

Characteristic resistances of anchor channels (HAC-C) under shear load – steel failure

Annex C9

Table 26: Characteristic resistances under shear load in direction of longitudinal axis of the channel – steel failure of HAC-C-T (hot-rolled serrated) anchor channels

Anchor channel				HAC-C-T 29/20	HAC-C-T 40/22	HAC-C-T 40L	HAC-C-T 50/30	HAC-C-T 50L	HAC-C-T 53/34
Steel failure: Connection between channel lips and channel bolt									
Characteristic resistance	HBC-T 29/20 M10	Carbon steel	$V_{Rk,s,l,x}$ [kN]	20,0	- 1)				
		Stainless steel							
	HBC-T 29/20 M12	Carbon steel			- 1)				
		Stainless steel							
	HBC-T 40/22 M10	Carbon steel			- 1)	28,0	- 1)		
		Stainless steel							
	HBC-T 40/22 M12	Carbon steel			- 1)	28,0	- 1)		
		Stainless steel							
	HBC-T 40/22 M16	Carbon steel			- 1)	40,0	- 1)		
		Stainless steel							
HBC-T 50/30 M16	Carbon steel	- 1)		50,0	50,0				
	Stainless steel								
HBC-T 50/30 M20	Carbon steel	- 1)		55,0	55,0				
	Stainless steel								
Installation factor	Carbon steel	γ_{inst}	[-]	1,2	1,2	1,4	1,4		
	Stainless steel			1,0	1,2	1,4	1,0		

1) No performance assessed

Table 27: Characteristic resistances under shear load in direction of longitudinal axis of the channel – steel failure HAC-C(-P) (hot-rolled) anchor channels

Anchor channel				HAC-C 40/22	HAC-C-P 40/22	HAC-C-P 40L	HAC-C 50/30	HAC-C-P 50/30	HAC-C-P 50L	HAC-C 52/34
Steel failure: Connection between channel lips and channel bolt										
Characteristic resistance	HBC-40/22-N M16 8.8F	$V_{Rk,s,l,x}$ [kN]	[-]	- 2)	12,5	12,5	- 1)			
	HBC-50/30-N M16 8.8F				- 2)					
	HBC-50/30-N M20 8.8F				- 2)		8,3	8,3	8,3	
Installation factor		γ_{inst}	[-]	- 2)	1,4	- 2)	1,0			

1) Product not available

2) No performance assessed

Hilti anchor channels (HAC) with channel bolts (HBC)

Performance

Characteristic resistances of anchor channels (HAC-C) under shear load – steel failure

Annex C10

Table 28: Characteristic resistances under shear load – concrete failure of HAC-C-T (hot-rolled serrated) anchor channels

Anchor channel				HAC-C-T 29/20	HAC-C-T 40/22	HAC-C-T 40L	HAC-C-T 50/30	HAC-C-T 50L	HAC-C-T 53/34
Concrete failure: Pry out									
Product factor	k_8	[-]		2,0					
Partial factor	$\gamma_{Mc}^{1)}$	[-]		1,5					
Concrete failure: Concrete edge									
Product factor k_{12}	Cracked concrete	$k_{cr,V}$	[-]	7,5					
	Uncracked concrete	$k_{ucr,V}$	[-]	10,5					
Partial factor	$\gamma_{Mc}^{1)}$	[-]		1,5					

¹⁾ In absence of other national regulations

Table 29: Characteristic resistances under shear load – concrete failure of HAC-C-P (hot-rolled) anchor channels

Anchor channel				HAC-C 40/22	HAC-C-P 40/22	HAC-C-P 40L	HAC-C 50/30	HAC-C-P 50/30	HAC-C-P 50L	HAC-C 52/34
Concrete failure: Pry out										
Product factor	k_8	[-]		2,0						
Partial factor	$\gamma_{Mc}^{1)}$	[-]		1,5						
Concrete failure: Concrete edge										
Product factor k_{12}	Cracked concrete	$k_{cr,V}$	[-]	7,5						
	Uncracked concrete	$k_{ucr,V}$	[-]	10,5						
Partial factor	$\gamma_{Mc}^{1)}$	[-]		1,5						

¹⁾ In absence of other national regulations

Table 30: Characteristic resistances under shear load – concrete failure of HAC-C (cold-formed) anchor channels

Anchor channel				HAC-C 28/15	HAC-C 38/17	HAC-C 40/25	HAC-C 49/30	HAC-C 54/33
Concrete failure: Pry out								
Product factor	k_8	[-]	1,0	2,0				
Partial factor	$\gamma_{Mc}^{1)}$	[-]		1,5				
Concrete failure: Concrete edge								
Product factor k_{12}	Cracked concrete	$k_{cr,V}$	[-]	6,9	6,9	7,5		
	Uncracked concrete	$k_{ucr,V}$	[-]	9,6	9,6	10,5		
Partial factor	$\gamma_{Mc}^{1)}$	[-]		1,5				

¹⁾ In absence of other national regulations

Hilti anchor channels (HAC) with channel bolts (HBC)

Performance

Characteristic resistances of anchor channels (HAC-C) under shear load – steel failure

Annex C11

Table 31: Displacements under shear load of HAC-C-T (hot-rolled serrated) anchor channels

Anchor channel			HAC-C-T 29/20		HAC-C-T 40/22; HAC-C-T 40L			HAC-C-T 50/30; HAC-C-T 50L		HAC-C-T 53/34	
			M10	M12	M10	M12	M16	M16	M20	M16	M20
Carbon steel											
Perpendicular shear load	V_y	[kN]	23,3		32,8			51,9		69,0	
Short-term displacement ¹⁾	$\delta_{V0,y}$	[mm]	1,6		2,1			2,0		2,8	
Long-term displacement ¹⁾	$\delta_{V\infty,y}$	[mm]	2,4		3,2			3,0		4,2	
Longitudinal shear load	V_x	[kN]	13,2	15,7	14,5	19,1	25,1	35,4	49,6	33,1	40,6
Short-term displacement ¹⁾	$\delta_{V0,x}$	[mm]	1,1	0,7	0,9	1,0	1,2	1,4	1,5	1,4	1,5
Long-term displacement ¹⁾	$\delta_{V\infty,x}$	[mm]	1,7	1,1	1,4	1,5	1,8	2,1	2,3	2,1	2,3
Stainless steel											
Perpendicular shear load	V_y	[kN]	25,0		34,7			61,8		66,8	
Short-term displacement ¹⁾	$\delta_{V0,y}$	[mm]	1,7		2,5			2,5		2,5	
Long-term displacement ¹⁾	$\delta_{V\infty,y}$	[mm]	2,6		3,8			3,8		3,8	
Longitudinal shear load	V_x	[kN]	14,5	17,1	16,9	20,4	26,5	42,1	53,8	38,4	
Short-term displacement ¹⁾	$\delta_{V0,x}$	[mm]	1,1	2,4	0,7	2,1	0,9	1,4	1,6	1,3	
Long-term displacement ¹⁾	$\delta_{V\infty,x}$	[mm]	1,6	3,6	1,1	3,2	1,4	2,1	2,4	2,0	

¹⁾ Displacements in midspan of the anchor channel, including slip of channel bolt, deformation of channel lips and slip of the anchor channel in concrete

Table 32: Displacements under shear load of HAC-C(-P) (hot-rolled) anchor channels

Anchor channel			HAC-C 40/22	HAC-C-P 40/22	HAC-C-P 40L	HAC-C 50/30	HAC-C-P 50/30	HAC-C-P 50L	HAC-C 52/34
			Perpendicular shear load	V_y	[kN]	10,3	29,0	29,0	16,0
Short-term displacement ¹⁾	$\delta_{V0,y}$	[mm]	2,1	2,0	2,0	2,6	2,7	3,7	3,7
Long-term displacement ¹⁾	$\delta_{V\infty,y}$	[mm]	3,1	3,5	3,5	3,9	4,0	5,5	5,5
Longitudinal shear load	V_x	[kN]	²⁾	5,2	5,2	²⁾	3,3	3,3	7,9
Short-term displacement ¹⁾	$\delta_{V0,x}$	[mm]	²⁾	0,1	0,1	²⁾	0,1	0,1	1,4
Long-term displacement ¹⁾	$\delta_{V\infty,x}$	[mm]	²⁾	0,2	0,2	²⁾	0,2	0,2	2,0

¹⁾ Displacements in midspan of the anchor channel, including slip of channel bolt, deformation of channel lips and slip of the anchor channel in concrete;

²⁾ No performance assessed

Hilti anchor channels (HAC) with channel bolts (HBC)

Performance
Displacements under shear load

Annex C12

Table 33: Displacements under shear load perpendicular to longitudinal axis of HAC-C (cold-formed) anchor channels

Anchor channel			HAC-C 28/15	HAC-C 38/17	HAC-C 40/25	HAC-C 49/30	HAC-C 54/33
Perpendicular shear load	V_y	[kN]	3,6	7,1	7,9	12,3	21,8
Short-term displacement ¹⁾	$\delta_{V0,y}$	[mm]	0,6	1,3	1,4	1,4	1,6
Long-term displacement ¹⁾	$\delta_{V\infty,y}$	[mm]	0,9	2,0	2,1	2,1	2,4

¹⁾ Displacements in midspan of the anchor channel, including slip of channel bolt, deformation of channel lips and slip of the anchor channel in concrete

Table 34: Characteristic resistances under combined tension and shear load of HAC-C-T (hot-rolled serrated) anchor channels

Anchor channel			HAC-C-T 29/20	HAC-C-T 40/22	HAC-C-T 40L	HAC-C-T 50/30	HAC-C-T 50L	HAC-C-T 53/34
Steel failure: Local flexure of channel lips and flexure of channel								
Product factor	k_{13}	[-]	Values according to EN 1992-4, Section 7.4.3.1					
Steel failure: Anchor and connection between anchor and channel								
Product factor	k_{14}	[-]	Values according to EN 1992-4, Section 7.4.3.1					

Table 35: Characteristic resistances under combined tension and shear load of HAC-C-P (hot-rolled) anchor channels

Anchor channel			HAC-C 40/22	HAC-C-P 40/22	HAC-C-P 40L	HAC-C 50/30	HAC-C-P 50/30	HAC-C-P 50L	HAC-C 52/34
Steel failure: Local flexure of channel lips and flexure of channel									
Product factor	k_{13}	[-]	Values according to EN 1992-4, Section 7.4.3.1						
Steel failure: Anchor and connection between anchor and channel									
Product factor	k_{14}	[-]	Values according to EN 1992-4, Section 7.4.3.1						

Table 36: Characteristic resistances under combined tension and shear load of HAC-C (cold-formed) anchor channels

Anchor channel			HAC-C 28/15	HAC-C 38/17	HAC-C 40/25	HAC-C 49/30	HAC-C 54/33
Steel failure: Local flexure of channel lips and flexure of channel							
Product factor	k_{13}	[-]	Values according to EN 1992-4, Section 7.4.3.1				
Steel failure: Anchor and connection between anchor and channel							
Product factor	k_{14}	[-]	Values according to EN 1992-4, Section 7.4.3.1				

Hilti anchor channels (HAC) with channel bolts (HBC)

Performance

Displacements under shear load
Characteristic resistance under combined tension and shear load

Annex C13

Table 37: Characteristic resistances under tension load – steel failure of channel bolts (HBC)

Channel bolt			M8	M10	M12	M16	M20		
Steel failure									
Characteristic resistance (tension load)	$N_{Rk,s}^{1)}$	[kN]	Bolts for hot-rolled serrated (HAC-C-T) anchor channels						
			HBC-T 29/20	8.8	- ³⁾	46,4	67,4	- ³⁾	
				A4-70 ¹⁾	- ³⁾	40,6	59,0	- ³⁾	
			HBC-T 40/22	8.8	- ³⁾	46,4	67,4	125,6	- ³⁾
				A4-70 ¹⁾	- ³⁾	40,6	59,0	109,9	- ³⁾
			HBC-T 50/30	8.8	- ³⁾			125,6	203,4
				A4-70 ¹⁾	- ³⁾			109,9	171,5
			Bolts for hot-rolled and/or cold-formed smooth (HAC-C) anchor channels						
			HBC-40/22	8.8	- ³⁾	- ³⁾	67,4	125,6	- ³⁾
				A4-70 ¹⁾	- ³⁾	20,5	59,0	91,0	- ³⁾
			HBC-40/22-N	8.8	- ³⁾			125,6	- ³⁾
				A4-70 ¹⁾	- ³⁾				
			HBC-50/30	8.8	- ³⁾		67,4	125,6	147,1
				A4-70 ¹⁾	- ³⁾		59,0	109,9	121,2
			HBC-50/30-N	8.8	- ³⁾			125,6	186,6
				A4-70 ¹⁾	- ³⁾				
			Bolts for cold-formed smooth (HAC-C) anchor channels						
			HBC-28/15	8.8	22,4	35,4	44,3	- ³⁾	
				A4-70 ¹⁾	25,6	38,9	51,3	- ³⁾	
			HBC-38/17	8.8	- ³⁾	35,4	35,4	55,8	- ³⁾
				A4-70 ¹⁾	- ³⁾	20,5	47,2	53,0	- ³⁾
Partial factor	$\gamma_{Ms}^{2)}$	[-]	HBC-T 29/20 HBC-T 40/22 HBC-T 50/30	8.8	1,50 and 1,51 ⁴⁾				
			HBC-40/22(-N) HBC-50/30(-N) HBC-28/15 HBC-38/17	A4-70 ¹⁾	1,87				

1) Materials according to Table 5, Annex A8

2) In absence of other national regulations

3) Product not available

4) Partial factor 1,51 for the bolt HBC-T 50/30 M20 and 1,5 for the other bolts

Hilti anchor channels (HAC) with channel bolts (HBC)

Performance

Characteristic resistances of channel bolts under tension load

Annex C14

Table 38: Characteristic resistances under shear load – steel failure of channel bolts (HBC)

Channel bolt		M8	M10	M12	M16	M20			
Steel failure									
Characteristic resistance (shear load)	$V_{Rk,s}^{1)}$	[kN]	Bolts for hot-rolled serrated (HAC-C-T) anchor channels						
			HBC-T 29/20	8.8	- ³⁾	23,2	33,7	- ³⁾	
				A4-70 ¹⁾	- ³⁾	24,4	35,4	- ³⁾	
			HBC-T 40/22	8.8	- ³⁾	23,2	33,7	62,8	- ³⁾
				A4-70 ¹⁾	- ³⁾	24,4	35,4	65,9	- ³⁾
			HBC-T 50/30	8.8	- ³⁾			62,8	101,7
				A4-70 ¹⁾	- ³⁾			65,9	102,9
			Bolts for hot-rolled and/or cold-formed smooth (HAC-C) anchor channels						
			HBC-40/22	8.8	- ³⁾	23,2	33,7	62,8	- ³⁾
				A4-70 ¹⁾	- ³⁾	24,4	35,4	65,9	- ³⁾
			HBC-40/22-N	8.8	- ³⁾			62,8	- ³⁾
				A4-70 ¹⁾	- ³⁾				
			HBC-50/30	8.8	- ³⁾		33,7	62,8	101,7
				A4-70 ¹⁾	- ³⁾		35,4	65,9	102,9
			HBC-50/30-N	8.8	- ³⁾			62,8	101,7
				A4-70	- ³⁾				
			Bolts for cold-formed smooth (HAC-C) anchor channels						
			HBC-28/15	8.8	14,6	23,2	33,7		- ³⁾
				A4-70	15,4	24,4	35,4		- ³⁾
			HBC-38/17	8.8	- ³⁾	23,2	33,7	62,8	- ³⁾
				A4-70 ¹⁾	- ³⁾	24,4	35,4	65,9	- ³⁾
Partial factor	$\gamma_{Ms}^{2)}$	[-]	HBC-T 29/20 HBC-T 40/22 HBC-T 50/30	8.8	1,25 and 1,26 ⁴⁾				
			HBC-40/22(-N) HBC-50/30(-N) HBC-28/15 HBC-38/17	A4-70	1,56				

¹⁾ Materials according to Table 5, Annex A8

²⁾ In absence of other national regulations

³⁾ Product not available

⁴⁾ Partial factor 1,26 for the bolt HBC-T 50/30 M20 and 1,25 for the other bolts

Hilti anchor channels (HAC) with channel bolts (HBC)

Performance

Characteristic resistances of channel bolts under shear load

Annex C15

Table 39: Characteristic resistances under shear load with lever arm – steel failure of channel bolts (HBC)

Channel bolt				M8	M10	M12	M16	M20	
Steel failure									
Characteristic flexural resistance	$M^{0}_{RK,s}{}^{5)}$	[Nm]	HBC-T 29/20	8,8	- ³⁾	59,8	104,8	- ³⁾	
				A4-70 ²⁾	- ³⁾	52,3	91,7	- ³⁾	
			HBC-T 40/22	8,8	- ³⁾	59,8	104,8	266,4	- ³⁾
				A4-70 ²⁾	- ³⁾	52,3	91,7	233,1	- ³⁾
			HBC-T 50/30	8,8	- ³⁾			266,4	538,7
				A4-70 ²⁾	- ³⁾			233,1	454,4
			HBC-50/30(-N) HBC-40/22(-N) HBC-38/17 HBC-28/15	8,8	30,0	59,8	104,8	266,4	538,7
				A4-70 ²⁾	26,2	52,3	91,7	233,1	454,4
Partial factor	$\gamma_{Ms}{}^{1)}$	[-]	HBC-T 29/20 HBC-T 40/22 HBC-T 50/30 HBC-40/22(-N) HBC-50/30(-N) HBC-28/15 HBC-38/17	8,8	1,25 and 1,26 ⁴⁾				
				A4-70 ²⁾	1,56				
Internal lever arm	a	[mm]	HBC-T 29/20	29/20	- ³⁾	19,0	20,0	- ³⁾	
			HBC-T 40/22	40/22	- ³⁾	23,0	24,0	26,0	- ³⁾
			HBC-T 50/30	50/30	- ³⁾			32,0	34,0
				53/34	- ³⁾			32,0	34,0
			HBC-40/22(-N)	40/22	- ³⁾	24,3	25,7	27,3	- ³⁾
			HBC-50/30(-N)	50/30	- ³⁾		29,9	31,7	33,9
			HBC-28/15	28/15	17,3	18,7	20,0	- ³⁾	
HBC-38/17	38/17	- ³⁾	23,0	24,3	26,3	- ³⁾			

¹⁾ In absence of other national regulations;
²⁾ Materials according to Table 5, Annex A8;

³⁾ Product not available;
⁴⁾ Partial factor 1,26 for the bolt HBC-T 50/30 M20 and 1,25 for the other bolts

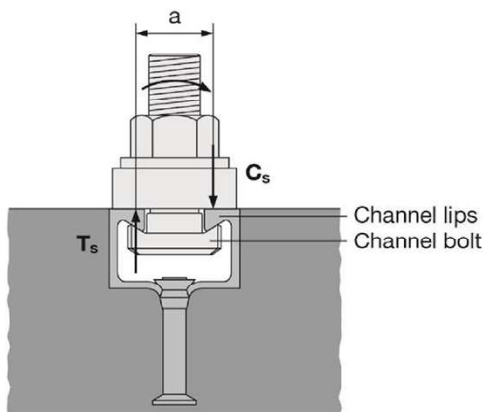

⁵⁾ The characteristic flexure resistance according to Table 39 is limited as follows:

$$M^{0}_{RK,s} \leq 0,5 \cdot N_{RK,s,l} \cdot a \quad (N_{RK,s,l} \text{ according to Table 11, 12 and 13})$$

and

$$M^{0}_{RK,s} \leq 0,5 \cdot N_{RK,s} \cdot a \quad (N_{RK,s} \text{ according to Table 37})$$

a = internal lever arm according Table 39

T_s = tension force acting on the channel lips

C_s = compression force acting on the channel lips

Hilti anchor channels (HAC-C) with channel bolts (HBC)

Performance

Characteristic resistances of channel bolts under shear load with lever arm

Annex C16

Table 40: Combination of anchor channels and channel bolts under fatigue tension load (Design method I or II for assessment method A1, A2 and B according to EOTA TR050)

Anchor channel			Channel bolt			
Channel profile	Anchor type ¹⁾	Corrosion protection	Channel bolt	Diameter	Steel grade	Corrosion protection
HAC-C-T 29/20	R	F	HBC-T 29/20	M10	8.8	G F
				M12		
HAC-C-T 40/22			HBC-T 40/22	M12		
HAC-C-T 40L				M16		
HAC-C-T 50/30			HBC-T 50/30	M16		
HAC-C-T 50L				M20		
HAC-C-T 53/34						
HAC-C-P 40/22			HBC-40/22	M12		
HAC-C-P 40L				M16		
HAC-C-P 50/30			HBC-50/30	M16		
HAC-C-P 50L				M20		
HAC-C 52/34			HBC-50/30	M16		
				M20		

¹⁾ R – Round anchor according Annexes A3 and A6

Hilti anchor channels (HAC-C) with channel bolts (HBC)

Performance

Characteristic resistances under fatigue tension load according to assessment method A1, A2 and B

Annex C17

Table 41: Characteristic resistances under fatigue tension load - steel failure with n load cycles without static preload ($N_{Ed} = 0$) (Design method I according to EOTA TR050) for HAC-C-T (hot-rolled serrated) anchor channels

Anchor channel				HAC-C-T 29/20	HAC-C-T 40/22	HAC-C-T 40L	HAC-C-T 50/30	HAC-C-T 50L	HAC-C-T 53/34
Steel failure									
Characteristic resistance under fatigue tension load after n load cycles without static preload ($N_{Ed} = 0$)	$\Delta N_{Rk,s,0,n}$	[kN]	$\leq 10^4$	15,4	20,4		20,3		33,5
			$\leq 10^5$	8,4	10,8		8,5		18,2
			$\leq 10^6$	4,4	4,9		4,5		9,0
			$\leq 2 \cdot 10^6$	3,9	4,1		4,2		7,5
			$\leq 5 \cdot 10^6$	3,4	3,4		4,0		6,1
			$\leq 10^8$	3,0	2,8		3,9		4,6
			$> 10^8$	3,0	2,8		3,9		4,5

Table 42: Characteristic resistances under fatigue tension load - steel failure with n load cycles without static preload ($N_{Ed} = 0$) (Design method I according to EOTA TR050) for HAC-C(-P) (hot-rolled) anchor channels

Anchor channel				HAC-C-P 40/22	HAC-C-P 40L	HAC-C-P 50/30	HAC-C-P 50L	HAC-C 52/34	
Steel failure									
Characteristic resistance under fatigue tension load after n load cycles without static preload ($N_{Ed} = 0$)	$\Delta N_{Rk,s,0,n}$	[kN]	$\leq 10^4$		16,4		20,9		24,3
			$\leq 10^5$		7,7		9,0		12,5
			$\leq 10^6$		3,2		4,2		7,1
			$\leq 2 \cdot 10^6$		2,6		3,7		6,4
			$\leq 5 \cdot 10^6$		2,2		3,4		5,9
			$\leq 10^8$		2,0		3,3		5,7
			$> 10^8$		1,8		3,2		5,5

Hilti anchor channels (HAC-C) with channel bolts (HBC)

Performance

Characteristic resistances under fatigue tension load according to assessment method A1, A2 and B

Annex C18

Table 43: Reduction factor $\eta_{c,fat}$ under fatigue tension load – concrete failure with n load cycles without static preload ($N_{Ed} = 0$) for HAC-C-T (hot-rolled serrated) anchor channels (Design method I or II for assessment method A1, A2 and B according to EOTA TR050)

Anchor channel			HAC-C-T 29/20	HAC-C-T 40/22	HAC-C-T 40L	HAC-C-T 50/30	HAC-C-T 50L	HAC-C-T 53/34
Pull-out failure; Concrete cone failure								
Reduction factor for $\Delta N_{RK,p;0;n} = \eta_{c,fat} \cdot N_{RK,p}$ $\Delta N_{RK,c;0;n} = \eta_{c,fat} \cdot N_{RK,c}$ with $N_{RK,p}$ according to Annex C4 and $N_{RK,c}$ calculated according to EN 1992-4 and EOTA TR 047	$\eta_{c,fat}$	[-]	$\leq 10^4$	0,736				
			$\leq 10^5$	0,665				
			$\leq 10^6$	0,600				
			$\leq 2 \cdot 10^6$	0,582				
			$\leq 5 \cdot 10^6$	0,559				
			$\leq 6 \cdot 10^7$	0,500				
			$> 6 \cdot 10^7$ ¹⁾	0,500				

¹⁾ for $\Delta N_{RK,p;0;\infty}$, $\Delta N_{RK,c;0;\infty}$

Table 44: Reduction factor $\eta_{c,fat}$ under fatigue tension load – concrete failure with n load cycles without static preload ($N_{Ed} = 0$) for HAC-C (hot-rolled) anchor channels (Design method I or II for assessment method A1, A2 and B according to EOTA TR050)

Anchor channel			HAC-C-P 40/22	HAC-C-P 40L	HAC-C-P 50/30	HAC-C-P 50L	HAC-C 52/34
Pull-out failure; Concrete cone failure							
Reduction factor for $\Delta N_{RK,p;0;n} = \eta_{c,fat} \cdot N_{RK,p}$ $\Delta N_{RK,c;0;n} = \eta_{c,fat} \cdot N_{RK,c}$ with $N_{RK,p}$ according to Annex C5 and $N_{RK,c}$ calculated according to EN 1992-4 and EOTA TR 047	$\eta_{c,fat}$	[-]	$\leq 10^4$	0,736			
			$\leq 10^5$	0,665			
			$\leq 10^6$	0,600			
			$\leq 2 \cdot 10^6$	0,582			
			$\leq 5 \cdot 10^6$	0,559			
			$\leq 6 \cdot 10^7$	0,500			
			$> 6 \cdot 10^7$ ¹⁾	0,500			

¹⁾ for $\Delta N_{RK,p;0;\infty}$, $\Delta N_{RK,c;0;\infty}$

Hilti anchor channels (HAC-C) with channel bolts (HBC)

Performance

Characteristic resistances under fatigue cyclic tension load according to assessment method A1, A2 and B

Annex C19

Table 45: Characteristic resistances under fatigue tension load – steel failure with $n \rightarrow \infty$ load cycles without static preload ($N_{Ed} = 0$) (Design method II for assessment method B according to EOTA TR050) for HAC-C-T (hot-rolled serrated) anchor channels

Anchor channel				HAC-C-T 29/20	HAC-C-T 40/22	HAC-C-T 40L	HAC-C-T 50/30	HAC-C-T 50L	HAC-C-T 53/34
Steel failure									
Characteristic fatigue limit resistance ($n \rightarrow \infty$) for any steel failure without static preload ($N_{Ed} = 0$)	$\Delta N_{Rk,s;0;\infty}$	[kN]	$n \rightarrow \infty$	3,0	2,8		3,9		4,5
Concrete cone and pull-out failure									
Reduction factor for fatigue limit resistance ($n \rightarrow \infty$) for concrete cone/pullout failure without static preload ($N_{Ed} = 0$)	$\eta_{c,fat}$	[-]	$n \rightarrow \infty$				0,5		

Table 46: Characteristic resistances under fatigue tension load – steel failure with $n \rightarrow \infty$ load cycles without static preload ($N_{Ed} = 0$) (Design method II for assessment method B according to EOTA TR050) for HAC-C (hot-rolled) anchor channels

Anchor channel				HAC-C-P 40/22	HAC-C-P 40L	HAC-C-P 50/30	HAC-C-P 50L	HAC-C 52/34	
Steel failure									
Characteristic fatigue limit resistance ($n \rightarrow \infty$) for any steel failure without static preload ($N_{Ed} = 0$)	$\Delta N_{Rk,s;0;\infty}$	[kN]	$n \rightarrow \infty$	1,8			3,2		5,5
Concrete cone and pull-out failure									
Reduction factor for fatigue limit resistance ($n \rightarrow \infty$) for concrete cone/pullout failure without static preload ($N_{Ed} = 0$)	$\eta_{c,fat}$	[-]	$n \rightarrow \infty$				0,5		

For the reduction of the characteristic resistances given in Tables 41, 42, 45 and 46 in the transition zone from the static resistance to the fatigue limit resistance the partial factors are calculated as follows:

$$\gamma_{M,fat,n} = \gamma_{M,fat} + (\gamma_M - \gamma_{M,fat}) \cdot (\Delta N_{Rk,n} - \Delta N_{Rk,\infty}) / (N_{Rk} - \Delta N_{Rk,\infty})$$

In absence of other national regulations, the following partial factors γ_M and $\gamma_{M,fat}$ are recommended for design method I according to EOTA TR 050:

γ_M according to Annex C1

$$\gamma_{M,fat} = 1,35$$

In absence of other national regulations, the following safety factor $\gamma_{M,fat}$ is recommended for design method II (Table 34) according to EOTA TR 050:

$$\gamma_{M,fat} = 1,35$$

Hilti anchor channels (HAC-C) with channel bolts (HBC)

Performance

Characteristic resistances under fatigue cyclic tension load according to assessment method A1, A2 and B

Annex C20

Table 47: Combination of anchor channels and channel bolts under seismic load (seismic performance category C1)

Anchor channel	Channel bolt			
	Channel bolt	Diameter	Steel grade	Corrosion protection
HAC-C-T 29/20	HBC-T 29/20	M10	8.8 A4	F ¹⁾ R ²⁾
		M12		
HAC-C-T 40/22 HAC-C-T 40L	HBC-T 40/22	M12		
		M16		
HAC-C-T 50/30 HAC-C-T 50L HAC-C-T 53/34	HBC-T 50/30	M16		
		M20		

¹⁾ Hot dip galvanized;

²⁾ Stainless steel

Table 48: Characteristic resistances under seismic tension load – steel failure of HAC-C-T (serrated hot-rolled) anchor channels

Anchor channel				HAC-C-T 29/20	HAC-C-T 40/22	HAC-C-T 40L	HAC-C-T 50/30	HAC-C-T 50L	HAC-C-T 53/34
Steel failure: Anchor									
Characteristic resistance	Carbon steel	$N_{Rk,s,a,eq}$	[kN]	35,0	41,0		57,0	73,5	
	Stainless steel				45,0				
Partial factor		$\gamma_{Ms,eq}$ ¹⁾	[-]	1,8					
Steel failure: Connection between anchor and channel									
Characteristic resistance	Carbon steel	$N_{Rk,s,c,eq}$	[kN]	33,0	40,0	55,0		73,5	
	Stainless steel			35,0	42,0	60,0			
Partial factor		$\gamma_{Ms,ca,eq}$ ¹⁾	[-]	1,8					
Steel failure: Local flexure of channel lips									
Characteristic spacing of channel bolts for $N_{Rk,s,l}$		$s_{l,N,eq}$	[mm]	61	76	100		107	
Characteristic resistance	Carbon steel	$N^0_{Rk,s,l,eq}$	[kN]	35,0	45,0		64,0		85,0
	Stainless steel				42,0				
Partial factor		$\gamma_{Ms,l,eq}$ ¹⁾	[-]	1,8					

¹⁾ In absence of other national regulations

Hilti anchor channels (HAC-C) with channel bolts (HBC)

Performance

Characteristic resistances of anchor channels and channel bolts under seismic load (Seismic performance category C1)

Annex C21

Table 49: Characteristic flexural resistance of HAC-C-T (hot-rolled serrated) channels under seismic tension load

Anchor channel				HAC-C-T 29/20	HAC-C-T 40/22	HAC-C-T 40 L	HAC-C-T 50/30	HAC-C-T 50L	HAC-C-T 53/34
Steel failure: Failure by flexure of channel									
Characteristic flexural resistance of channel	Carbon steel	$M_{Rk,s,flex,eq}$ [Nm]	[Nm]	977	1557		3256		4870
	Stainless steel			1100	1754		3366		4626
Partial factor		$\gamma_{Ms,flex}^{1)}$	[-]	1,15					

¹⁾ In absence of other national regulations.

Table 50: Characteristic resistances under seismic shear load – steel failure of HAC-C-T (hot-rolled serrated) anchor channels

Anchor channel				HAC-C-T 29/20	HAC-C-T 40/22	HAC-C-T 40L	HAC-C-T 50/30	HAC-C-T 50L	HAC-C-T 53/34
Steel failure: Anchor									
Characteristic resistance	Carbon steel	$V_{Rk,s,a,y,eq}$ [kN]	[kN]	37,0	52,0		80,0		120,0
	Stainless steel				49,5		100,0		
Characteristic resistance	Carbon steel	$V_{Rk,s,a,x,eq}$ [kN]	[kN]	22,9	24,7		35,2		44,1
	Stainless steel				28,3		37,1		
Partial factor		$\gamma_{Ms,eq}^{1)}$	[-]	1,5					
Steel failure: Connection between anchor and channel									
Characteristic resistance	Carbon steel	$V_{Rk,s,c,y,eq}$ [kN]	[kN]	37,0	52,0		80,0		120,0
	Stainless steel				49,5		100,0		
Characteristic resistance	Carbon steel	$V_{Rk,s,c,x,eq}$ [kN]	[kN]	19,8	24,0		31,4		44,1
	Stainless steel				21,0		36,0		
Partial factor		$\gamma_{Ms,eq}^{1)}$	[-]	1,8					
Steel failure: Local flexure of channel lips under shear load perpendicular to the longitudinal axis of the channel									
Characteristic spacing of channel bolts for $V_{Rk,s,l}$		$s_{l,V,eq}$	[mm]	61,0	76,0		100,0		107,0
Characteristic resistance	Carbon steel	$V_{Rk,s,l,y,eq}^0$ [kN]	[kN]	37,0	52,0		80,0		120,0
	Stainless steel				49,5		100,0		
Partial factor		$\gamma_{Ms,l,eq}^{1)}$	[-]	1,8					

¹⁾ In absence of other national regulations;

Hilti anchor channels (HAC-C) with channel bolts (HBC)

Performance

Characteristic resistances of anchor channels under seismic load (Seismic performance category C1)

Annex C22

Table 51: Characteristic resistances under seismic shear load in direction of the longitudinal axis of the channel – steel failure of HAC-C-T (hot-rolled serrated) anchor channels

Anchor channel				HAC-C-T 29/20	HAC-C-T 40/22	HAC-C-T 40L	HAC-C-T 50/30	HAC-C-T 50L	HAC-C-T 53/34
Steel failure: Connection between channel lips and channel bolt									
Characteristic resistance	HBC-T 29/20 M10	Carbon steel	$V_{Rk,s,l,x,eq}$ [kN]	20,0	- 1)				
		Stainless steel							
	HBC-T 29/20 M12	Carbon steel			- 1)				
		Stainless steel							
	HBC-T 40/22 M10	Carbon steel			- 1)	- 1)	- 1)		
		Stainless steel							
	HBC-T 40/22 M12	Carbon steel			- 1)	28,0	- 1)		
		Stainless steel							
	HBC-T 40/22 M16	Carbon steel			- 1)	40,0	- 1)		
		Stainless steel							
HBC-T 50/30 M16	Carbon steel	- 1)		50,0	50,0				
	Stainless steel			71,4	51,0				
HBC-T 50/30 M20	Carbon steel	- 1)		52,3	55,0				
	Stainless steel			71,4	51,0				
Installation factor		Carbon steel	$\gamma_{inst,eq}$	[-]	1,2	1,2	1,4	1,4	
		Stainless steel			1,0	1,2	1,4	1,0	

¹⁾ No performance assessed

Hilti anchor channels (HAC-C) with channel bolts (HBC)

Performance

Characteristic resistances of anchor channels and channel bolts under seismic load
(Seismic performance category C1)

Annex C23

Table 52: Characteristic resistances under seismic tension and seismic shear load – steel failure of channel bolts (HBC)

Channel bolt				M10	M12	M16	M20	
Steel failure								
Characteristic resistance (tension load)	$N_{Rk,s,eq}^{1)}$	[kN]	HBC-T 29/20	8.8	46,4	67,4	- ³⁾	
				A4-70 ¹⁾	40,6	59,0	- ³⁾	
			HBC-T 40/22	8.8	- ⁴⁾	67,4	125,6	- ³⁾
				A4-70 ¹⁾	- ⁴⁾	59,0	109,9	- ³⁾
			HBC-T 50/30	8.8	- ³⁾	-	125,6	203,4
				A4-70 ¹⁾	- ³⁾	-	109,9	171,5
Partial factor	$\gamma_{Ms,eq}^{2)}$	[-]	HBC-T 50/30 HBC-T 40/22 HBC-T 29/20	8.8	1,50 and 1,51 ⁵⁾			
			A4-70 ¹⁾	-	1,87			
Characteristic resistance (shear load)	$V_{Rk,s,eq}^{1)}$	[kN]	HBC-T 29/20	8.8	23,2	33,7	- ³⁾	
				A4-70 ¹⁾	24,4	35,4	- ³⁾	
			HBC-T 40/22	8.8	- ⁵⁾	33,7	62,8	- ³⁾
				A4-70 ¹⁾	- ⁵⁾	35,4	65,9	- ³⁾
			HBC-T 50/30	8.8	- ³⁾	-	62,8	101,7
				A4-70 ¹⁾	- ³⁾	-	65,9	102,9
Partial factor	$\gamma_{Ms,eq}^{2)}$	[-]	HBC-T 50/30 HBC-T 40/22 HBC-T 29/20	8.8	1,25 and 1,26 ⁵⁾			
			A4-70	-	1,56			

¹⁾ Materials according to Table 5, Annex A8

²⁾ In absence of other national regulations

³⁾ Product not available

⁴⁾ Performance not assessed

⁵⁾ Partial factors 1,51 and 1,26 for the bolt HBC-T 50/30 M20; 1,5 and 1,25 for the other bolts

Hilti anchor channels (HAC-C) with channel bolts (HBC)

Performance

Characteristic resistances of channel bolts under seismic load
(Seismic performance category C1)

Annex C24

Table 53: Characteristic resistance under fire exposure – steel failure for HAC-C(-T) (serrated hot-rolled) anchor channels

Channel bolt				M10	M12	M16	M20				
Steel failure: Anchor, connection between anchor and channel, local flexure of channel lip											
Carbon steel, Stainless steel A2											
Characteristic resistance under fire exposure	HAC-C-T 29/20	R30	$N_{Rk,s,fi}$ = $V_{Rk,s,y,fi}$	[kN]	1,2	1,2	- 2)	- 2)			
		R60			0,9	0,9					
		R90			0,6	0,6					
		R120			0,5	0,5					
	HAC-C-T 40/22	R30			1,2	1,2	6,2	- 2)			
		R60			0,9	0,9	4,6				
		R90			0,6	0,6	2,9				
		R120			0,5	0,5	2,1				
	HAC-C-T 50/30	R30			- 2)	- 2)	6,4	10,7			
		R60			- 2)	- 2)	4,8	8,0			
		R90			- 2)	- 2)	3,2	5,2			
		R120			- 2)	- 2)	2,3	3,8			
	HAC-C-T 53/34	R30			- 2)	- 2)	6,5	9,0			
		R60			- 2)	- 2)	5,0	6,7			
		R90			- 2)	- 2)	3,4	4,5			
		R120			- 2)	- 2)	2,7	3,4			
	Stainless steel A4										
	Characteristic resistance under fire exposure	HAC-C-T A4 29/20			R30	$N_{Rk,s,fi}$ = $V_{Rk,s,y,fi}$	[kN]	9,9	11,1	- 2)	- 2)
					R60			6,1	7,2		
					R90			2,2	3,4		
R120			0,3	1,4							
HAC-C-T A4 40/22		R30	9,9	11,1	20,0			- 2)			
		R60	6,1	7,2	17,7						
		R90	2,2	3,4	8,2						
		R120	0,3	1,4	3,5						
HAC-C-T A4 50/30		R30	- 2)	- 2)	20,0			20,0			
		R60	- 2)	- 2)	17,7			17,7			
		R90	- 2)	- 2)	8,2			8,2			
		R120	- 2)	- 2)	3,5			3,5			
HAC-C-T A4 53/34		R30	- 2)	- 2)	20,0			20,0			
		R60	- 2)	- 2)	17,7			17,7			
		R90	- 2)	- 2)	8,2			8,2			
		R120	- 2)	- 2)	3,5			3,5			
Partial safety factor			$\gamma_{Ms,fi}^{1)}$	[-]	1,0						

¹⁾ In absence of other national regulations

²⁾ Product not available

Hilti anchor channels (HAC-C) with channel bolts (HBC)

Performance

Characteristic resistances of anchor channels and channel bolts under fire exposure

Annex C25

Table 54: Characteristic resistance under fire exposure – steel failure for HAC-C(-P) (hot-rolled) anchor channels

Channel bolt				M10	M12	M16	M20			
Steel failure: Anchor, connection between anchor and channel, local flexure of channel lip										
Carbon steel and Stainless steel (A4)										
Characteristic resistance under fire exposure	HAC-C(-P) 40/22 HAC-C-P 40L	R60	$N_{Rk,s,fi}$ = $V_{Rk,s,y,fi}$	[kN]	- ³⁾	- ³⁾	3,5	- ²⁾		
		R90					2,2			
		R120					1,5			
	HAC-C(-P) 50/30 HAC-C-P 50L HAC-C 52/34	R60			- ²⁾	3,8	3,9			
		R90				2,5	2,9			
		R120				1,9	2,4			
	Partial safety factor				$\gamma_{Ms,fi}$ ¹⁾	[-]	1,0			

1) In absence of other national regulations

2) Product not available

3) Performance not assessed

Table 55: Characteristic resistance under fire exposure – steel failure for HAC-C (cold-formed) anchor channels

Channel bolt				M10	M12	M16	M20			
Steel failure of anchor, connection between anchor and channel, local flexure of channel lip										
Carbon steel and Stainless steel (A4)										
Characteristic resistance under fire exposure	HAC-C 28/15	R60	$N_{Rk,s,fi}$ = $V_{Rk,s,y,fi}$	[kN]	0,8		- ²⁾	- ²⁾		
		R90			0,6					
		R120			0,5					
	HAC-C 38/17	R60			- ³⁾	- ³⁾	1,9		- ²⁾	
		R90					1,3			
		R120					1,0			
	HAC-C 40/25	R60			1,7		3,5		- ²⁾	
		R90			1,2		2,2			
		R120			0,9		1,5			
	HAC-C 49/30	R60			- ²⁾	3,8		3,9		
		R90				2,5		2,9		
		R120				1,9		2,4		
	Partial safety factor				$\gamma_{Ms,fi}$ ¹⁾	[-]	1,0			

1) In absence of other national regulations

2) Product not available

3) Performance not assessed

Hilti anchor channels (HAC-C) with channel bolts (HBC)

Performance

Characteristic resistances of anchor channels and channel bolts under fire exposure

Annex C26

**Table 56: Minimum axis distance of reinforcement –
for HAC-C-T (hot-rolled serrated) anchor channels**

Anchor channel				HAC-C-T 29/20	HAC-C-T 40/22	HAC-C-T 40L	HAC-C-T 50/30	HAC-C-T 50L	HAC-C-T 53/34
Minimum axis distance	R30	a	[mm]	35			50		
	R60			35			50		
	R90			45			50		
	R120			55			55		

**Table 57: Minimum axis distance of reinforcement –
for HAC-C (cold-formed) and HAC-C(-P) (hot-rolled) anchor channels**

Anchor channel				HAC-C 28/15	HAC-C 38/17	HAC-C 40/25	HAC-C(-P) 40/22	HAC-C-P 40L	HAC-C 49/30	HAC-C(-P) 50/30	HAC-C-P 50L	HAC-C 54/33	HAC-C 52/34
Minimum axis distance	R60	a	[mm]	35					50				
	R90			45					50				
	R120			55					55				

Fire exposure from one side only

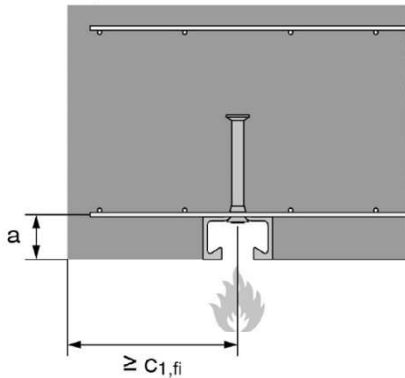

Fire exposure from more than one side

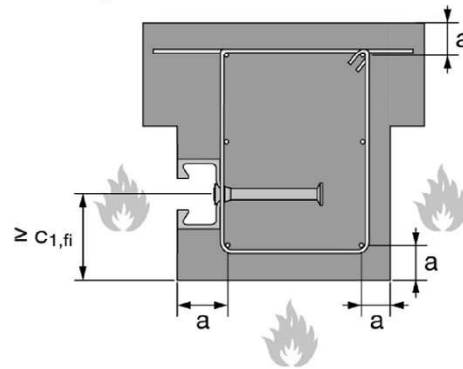

Hilti anchor channels (HAC-C) with channel bolts (HBC)

Performance

Characteristic resistances of anchor channels and channel bolts under fire exposure

Annex C27

Eine vom Bund und den Ländern gemeinsam
getragene Anstalt des öffentlichen Rechts

Europäische Technische
Bewertungsstelle für Bauprodukte



Europäische Technische Bewertung

ETA-17/0336
vom 29. August 2025

Allgemeiner Teil

Technische Bewertungsstelle, die die Europäische Technische Bewertung ausstellt

Handelsname des Bauprodukts

Produktfamilie,
zu der das Bauprodukt gehört

Hersteller

Herstellungsbetrieb

Diese Europäische Technische Bewertung enthält

Diese Europäische Technische Bewertung wird ausgestellt gemäß der Verordnung (EU) Nr. 305/2011, auf der Grundlage von

Diese Fassung ersetzt

Deutsches Institut für Bautechnik

Ankerschienen (HAC-C) mit Spezialschrauben (HBC)

Ankerschienen

Hilti AG

Feldkircherstraße 100

9494 Schaan

FÜRSTENTUM LIECHTENSTEIN

Hilti Werke

53 Seiten, davon 3 Anhänge, die fester Bestandteil dieser Bewertung sind.

EAD 330008-04-0601, Edition 07/2024

ETA-17/0336 vom 18. Juli 2024

Die Europäische Technische Bewertung wird von der Technischen Bewertungsstelle in ihrer Amtssprache ausgestellt. Übersetzungen dieser Europäischen Technischen Bewertung in andere Sprachen müssen dem Original vollständig entsprechen und müssen als solche gekennzeichnet sein.

Diese Europäische Technische Bewertung darf, auch bei elektronischer Übermittlung, nur vollständig und ungekürzt wiedergegeben werden. Nur mit schriftlicher Zustimmung der ausstellenden Technischen Bewertungsstelle kann eine teilweise Wiedergabe erfolgen. Jede teilweise Wiedergabe ist als solche zu kennzeichnen.

Die ausstellende Technische Bewertungsstelle kann diese Europäische Technische Bewertung widerrufen, insbesondere nach Unterrichtung durch die Kommission gemäß Artikel 25 Absatz 3 der Verordnung (EU) Nr. 305/2011.

Besonderer Teil

1 Technische Beschreibung des Produkts

Die Ankerschiene (HAC-C) mit Spezialschrauben (HBC) ist ein System bestehend aus einer C-förmigen Schiene aus Stahl oder nichtrostendem Stahl mit mindestens zwei auf dem Profilrücken unlösbar befestigten Anker und Spezialschrauben.

Die Ankerschiene wird oberflächenbündig einbetoniert. In den Schienen werden Spezialschrauben (HBC) mit entsprechenden Sechskantmutter und Unterlegscheiben befestigt. In Anhang A ist die Produktbeschreibung dargestellt.

2 Spezifizierung des Verwendungszwecks gemäß dem anwendbaren Europäischen Bewertungsdokument

Von den Leistungen in Abschnitt 3 kann nur ausgegangen werden, wenn die Ankerschiene entsprechend den Angaben und unter den Randbedingungen nach Anhang B verwendet wird.

Die Prüf- und Bewertungsmethoden, die dieser Europäischen Technischen Bewertung zu Grunde liegen, führen zur Annahme einer Nutzungsdauer der Ankerschiene von mindestens 50 Jahren. Die Angabe der Nutzungsdauer kann nicht als Garantie des Herstellers verstanden werden, sondern ist lediglich ein Hilfsmittel zur Auswahl des richtigen Produktes im Hinblick auf die erwartete wirtschaftlich angemessene Nutzungsdauer des Bauwerks.

3 Leistung des Produkts und Angabe der Methoden ihrer Bewertung

3.1 Mechanische Festigkeit und Standsicherheit (BWR 1)

Wesentliches Merkmal	Leistung
Charakteristischer Widerstand unter Zuglast (statische und quasi-statische Einwirkungen)	
- Widerstand gegen Stahlversagen der Anker	$N_{Rk,s,a}$ siehe Anhang C1 und C2
- Widerstand gegen Stahlversagen der Verbindung zwischen Anker und Schiene	$N_{Rk,s,c}$ siehe Anhang C1 und C2
- Widerstand gegen Stahlversagen der Schienenlippen und Herausziehen der Spezialschraube	$N_{Rk,s,l}^0 ; s_{l,N}$ siehe Anhang C1 und C2
- Widerstand gegen Stahlversagen der Spezialschraube	$N_{Rk,s}$ siehe Anhang C14
- Widerstand gegen Stahlversagen durch Überschreitung der Biegefestigkeit der Schiene	s_{max} siehe Anhang B3 und B4 $M_{Rk,s,flex}$ siehe Anhang C3
- Maximales Montagedrehmoment, um Schaden bei der Montage zu vermeiden	$T_{inst,g} ; T_{inst,s}$ siehe Anhang B5
- Widerstand gegen Herausziehen des Ankers	$N_{Rk,p}$ siehe Anhang C4 bis C6
- Widerstand gegen Betonausbruch	h_{ef} siehe Anhang B3 und B4 $k_{cr,N} ; k_{ucr,N}$ siehe Anhang C4 bis C6
- Min. Rand-, Achsabstand und min. Bauteildicke, um Spalten bei Montage zu vermeiden	s_{min} siehe Anhang B3 und B4 $c_{min} ; h_{min}$ siehe Anhang B3 und B4
- Charakteristischer Rand- und Achsabstand gegen Spalten unter Last	$s_{cr,sp} ; c_{cr,sp}$ siehe Anhang C4 bis C6
- Widerstand gegen lokalen Betonausbruch – lastabtragende Fläche des Ankerkopfes	A_h siehe Anhang A6

Wesentliches Merkmal	Leistung
<p>Charakteristischer Widerstand unter Querlast (statische und quasi-statische Einwirkungen)</p> <ul style="list-style-type: none"> - Widerstand gegen Stahlversagen der Spezialschraube unter Querlast ohne Hebelarm - Widerstand gegen Stahlversagen durch Biegung der Spezialschraube unter Querlast mit Hebelarm - Widerstand gegen Stahlversagen der Schienenlippen, Stahlversagen der Verbindung zwischen Anker und Schiene und Stahlversagen des Ankers (Querlast senkrecht zur Schienenlängsachse) - Widerstand gegen Stahlversagen der Verbindung zwischen Schienenlippen und Spezialschraube (Querlast in Schienenlängsrichtung) - Montagebeiwert (Querlast längs) - Widerstand gegen Stahlversagen der Anker (Querlast längs) - Widerstand gegen Stahlversagen der Verbindung zwischen Anker und Schiene (Querlast längs) - Widerstand gegen Betonausbruch auf der lastabgewandten Seite - Widerstand gegen Betonkantenbruch 	<p>$V_{Rk,s}$ siehe Anhang C15</p> <p>$M_{Rk,s}^0$ siehe Anhang C16</p> <p>$V_{Rk,s,l,y}^0$; $s_{l,v}$; $V_{Rk,s,c,y}$; $V_{Rk,s,a,y}$ siehe Anhang C8 und C9</p> <p>$V_{Rk,s,l,x}$ siehe Anhang C10</p> <p>γ_{inst} siehe Anhang C10</p> <p>$V_{Rk,s,a,x}$ siehe Anhang C8 und C9</p> <p>$V_{Rk,s,c,x}$ siehe Anhang C8 und C9</p> <p>k_8 siehe Anhang C11</p> <p>$k_{cr,v}$; $k_{ucr,v}$ siehe Anhang C11</p>
<p>Charakteristischer Widerstand unter kombinierter Zug- und Querlast (statische und quasi-statische Einwirkungen)</p> <ul style="list-style-type: none"> - Widerstand gegen Stahlversagen der Ankerschiene 	<p>k_{13}; k_{14} siehe Anhang C13</p>
<p>Charakteristische Widerstände für zyklische Ermüdungsbeanspruchungen unter Zuglast</p> <ul style="list-style-type: none"> - Ermüdungswiderstand gegen Stahlversagen des gesamten Systems (stetige oder tri-lineare Funktion, Prüfverfahren A1, A2) - Dauerermüdungswiderstand gegen Stahlversagen des gesamten Systems (Prüfverfahren B) - Ermüdungswiderstand gegen Stahlversagen des gesamten Systems (Lineare Funktion, Prüfverfahren C) - Ermüdungswiderstand gegen Betonversagen (Exponentialfunktion, Prüfverfahren A1, A2) - Dauerermüdungswiderstand gegen Betonversagen (Prüfverfahren B) - Ermüdungswiderstand gegen Betonversagen (Lineare Funktion, Prüfverfahren C) 	<p>$\Delta N_{Rk,s,0,n}$ ($n = 1$ bis $n = \infty$) siehe Anhang C18</p> <p>$\Delta N_{Rk,s,0,\infty}$ siehe Anhang C20</p> <p>Leistung nicht bewertet</p> <p>$\Delta N_{Rk,c,0,n}$; $\Delta N_{Rk,p,0,n}$ ($n = 1$ bis $n = \infty$) siehe Anhang C19</p> <p>$\Delta N_{Rk,c,0,\infty}$; $\Delta N_{Rk,p,0,\infty}$ siehe Anhang C20</p> <p>Leistung nicht bewertet</p>

Wesentliches Merkmal	Leistung
Charakteristischer Widerstand für seismischer Beanspruchung (Leistungskategorie C1) - Widerstand gegen Stahlversagen für seismische Beanspruchung unter Zuglast (Leistungskategorie C1) - Widerstand gegen Stahlversagen unter seismischer Beanspruchung für Querlast senkrecht zur Schienenlängsachse (Leistungskategorie C1) - Widerstand gegen Stahlversagen unter seismischer Querbeanspruchung in Schienenlängsrichtung (Leistungskategorie C1)	$N_{Rk,s,a,eq}$; $N_{Rk,s,c,eq}$; $N^0_{Rk,s,l,eq}$ siehe Anhang C21 $M_{Rk,s,flex,eq}$ siehe Anhang C22 $N_{Rk,s,eq}$ siehe Anhang C24 $V_{Rk,s,eq}$ siehe Anhang C24 $V^0_{Rk,s,l,y,eq}$; $V_{Rk,s,c,y,eq}$; $V_{Rk,s,a,y,eq}$ siehe Anhang C22 $V_{Rk,s,l,x,eq}$ siehe Anhang C23 $V_{Rk,s,a,x,eq}$; $V_{Rk,s,c,x,eq}$ siehe Anhang C22
Charakteristischer Widerstand unter Zug- und/oder Querlast (statische und quasi-statische Einwirkungen) - Verschiebungen (statische und quasi-statische Einwirkungen)	δ_{N0} ; $\delta_{N\infty}$ siehe Anhang C7 $\delta_{V,y,0}$; $\delta_{V,y,\infty}$; $\delta_{V,x,0}$; $\delta_{V,x,\infty}$ siehe Anhang C12 und C13

3.2 Brandschutz (BWR 2)

Wesentliches Merkmal	Leistung
Brandverhalten	Klasse A1
Feuerwiderstand	$N_{Rk,s,fi}$; $V_{Rk,s,y,fi}$ siehe Anhang C25 und C26

3.3 Aspekte der Dauerhaftigkeit in Bezug auf die Grundanforderungen an Bauwerke

Wesentliches Merkmal	Leistung
Dauerhaftigkeit	Siehe Anhang B1

4 Angewandtes System zur Bewertung und Überprüfung der Leistungsbeständigkeit mit der Angabe der Rechtsgrundlage

Gemäß dem Europäischen Bewertungsdokument EAD Nr. 330008-04-0601 gilt folgende Rechtsgrundlage: [2000/273/EG].

Folgendes System ist anzuwenden: 1

5 Für die Durchführung des Systems zur Bewertung und Überprüfung der Leistungsbeständigkeit erforderliche technische Einzelheiten gemäß anwendbarem Europäischen Bewertungsdokument

Technische Einzelheiten, die für die Durchführung des Systems zur Bewertung und Überprüfung der Leistungsbeständigkeit notwendig sind, sind Bestandteil des Kontrollplans, der beim Deutschen Institut für Bautechnik hinterlegt ist.

Folgende technische Spezifikationen werden in diesem Bescheid in Bezug genommen:

EN 10025-1:2004	Warmgewalzte Erzeugnisse aus Baustählen - Teil 1: Allgemeine technische Lieferbedingungen
EN 10149-1:2013	Warmgewalzte Flacherzeugnisse aus Stählen mit hoher Streckgrenze zum Kaltumformen - Teil 1: Allgemeine technische Lieferbedingungen
EN 10263-1:2017	Walzdraht, Stäbe und Draht aus Kaltstauch- und Kaltfließpressstählen - Teil 1: Allgemeine technische Lieferbedingungen
EN ISO 898-1:2013	Mechanische Eigenschaften von Verbindungselementen aus Kohlenstoffstahl und legiertem Stahl – Teil 1: Schrauben mit festgelegten Festigkeitsklassen - Regelgewinde und Feingewinde (ISO 898-1:2013)
EN ISO 898-2:2022	Verbindungselemente - Mechanische Eigenschaften von Verbindungselementen aus Kohlenstoffstahl und legiertem Stahl - Teil 2: Muttern mit festgelegten Festigkeitsklassen (ISO 898-2:2022)
EN ISO 7089:2000	Flache Scheiben - Normale Reihe, Produktklasse A (ISO 7089:2000)
EN ISO 7093-1:2000	Flache Scheiben - Große Reihe - Teil 1: Produktklasse A (ISO 7093-1:2000)
EN ISO 4032:2023	Verbindungselemente - Sechskantmuttern (Typ 1) (ISO 4032:2023)
DIN 934:1987-10	Sechskantmuttern; Metrisches Regel- und Feingewinde; Produktklassen A und B
EN ISO 1461:2022	Durch Feuerverzinken auf Stahl aufgebraute Zinküberzüge (Stückverzinken) - Anforderungen und Prüfungen (ISO 1461:2022)
EN ISO 4042:2022	Verbindungselemente - Galvanisch aufgebraute Überzugsysteme (ISO 4042:2022)
EN ISO 10684:2004 + AC:2009	Verbindungselemente – Feuerverzinkung (ISO 10684:2004 + Cor. 1:2008)
EN 10088-1:2023	Nichtrostende Stähle - Teil 1: Verzeichnis der nichtrostenden Stähle
EN ISO 3506-1:2020	Mechanische Verbindungselemente - Mechanische Eigenschaften von Verbindungselementen aus korrosionsbeständigen nichtrostenden Stählen - Teil 1: Schrauben mit festgelegten Stahlsorten und Festigkeitsklassen (ISO 3506-1:2020)
EN 206:2013 + A2:2021	Beton - Festlegung, Eigenschaften, Herstellung und Konformität
EN 1993-1-4:2006 + A1:2015 + A2:2020	Eurocode 3: Bemessung und Konstruktion von Stahlbauten - Teil 1-4: Allgemeine Bemessungsregeln - Ergänzende Regeln zur Anwendung von nichtrostenden Stählen
EN 1992-4:2018	Eurocode 2 - Bemessung und Konstruktion von Stahlbeton- und Spannbetontragwerken - Teil 4: Bemessung der Verankerung von Befestigungen in Beton
EOTA TR047:2021-05	Bemessung von Ankerschienen in Ergänzung zu EN 1992-4
EOTA TR050:2023-10	Bemessungsverfahren für Ankerschienen unter ermüdungsrelevanter Belastung

EN 1992-1-1:2023

Eurocode 2: Bemessung und Konstruktion von Stahlbeton- und
Spannbetontragwerken -
Teil 1-1: Allgemeine Regeln und Regeln für Hochbauten, Brücken
und Ingenieurbauwerke

Ausgestellt in Berlin am 29 August 2025 vom Deutschen Institut für Bautechnik

Dipl.-Ing. Andreas Kummerow
Abteilungsleiter

Beglaubigt
Müller

Produkt und Einbauzustand
(z.B. warmgewalzte Ankerschiene mit Rundanker)

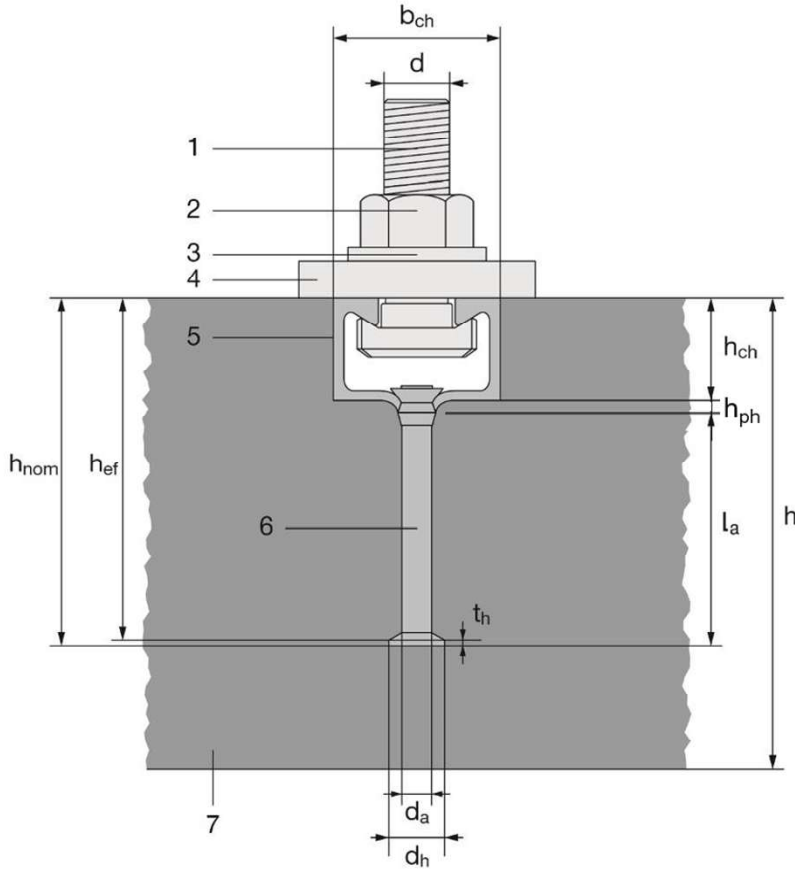

Legende

- 1 Spezialschraube
- 2 Sechskantmutter
- 3 Unterlegscheibe
- 4 Anbauteil
- 5 Schienenprofil
- 6 Anker
- 7 Betonbauteil

Ankerschienen (HAC-C) mit Spezialschrauben (HBC)

Produktbeschreibung
Einbauzustand

Anhang A1

Dichtung Schienenprofil

Schiene ohne zusätzliche Dichtung

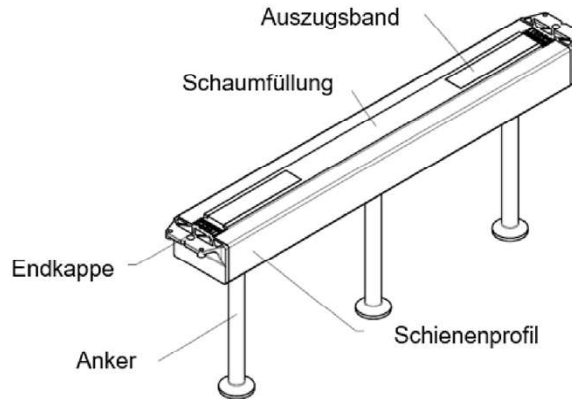

Schiene mit zusätzlicher Dichtung (seitliche Dichtung)

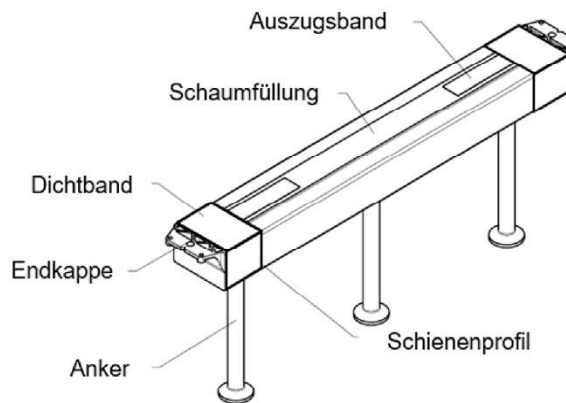

Schiene mit zusätzlicher Dichtung (Dichtung auf der Oberseite)

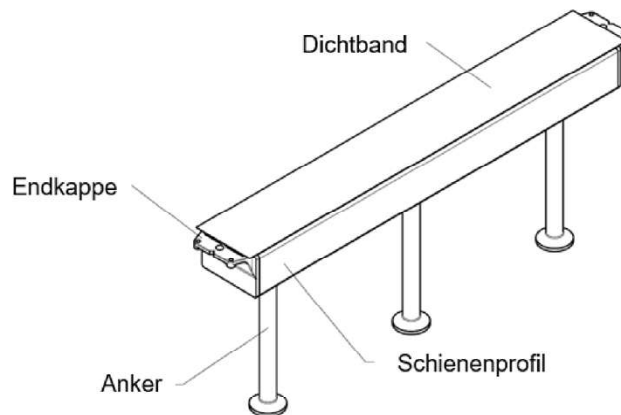

Ankerschienen (HAC-C) mit Spezialschrauben (HBC)

Produktbeschreibung
Dichtung des Schienenprofils

Anhang A2

Ankerschienentypen

Warmgewalzte
glatte und gezahnte (-T)
Schiennenprofil

Kaltverformte
glatte
Schiennenprofil

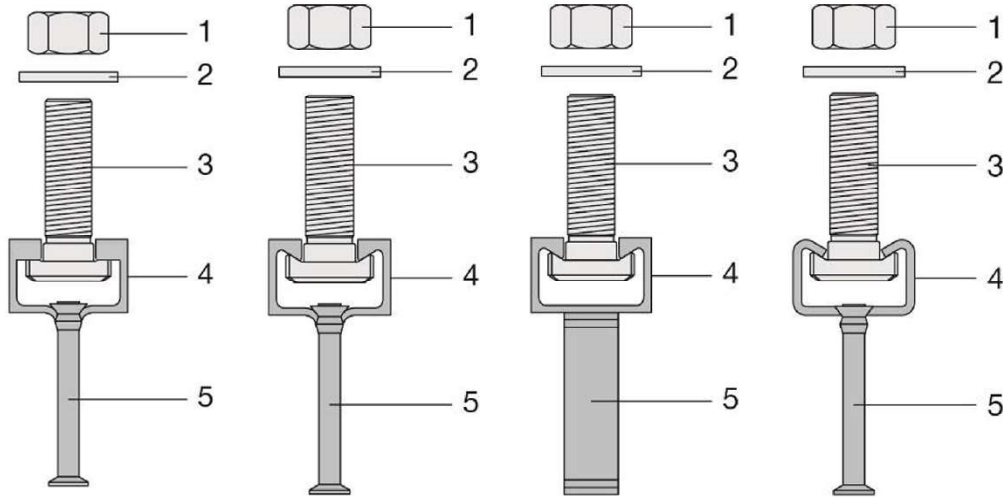

Legende

- 1 Sechskantmutter
- 2 Unterlegscheibe
- 3 Spezialschraube
- 4 Schiennenprofil
- 5 Anker

mit

Rundanker

HAC-C-T 29/20,
HAC-C-T 40/22,
HAC-C-T 40L,
HAC-C-T 50/30,
HAC-C-T 50L,
HAC-C-T 53/34

Rundanker oder

HAC-C(-P) 40/22,
HAC-C-P 40L,
HAC-C(-P) 50/30,
HAC-C-P 50L,
HAC-C 52/34

angeschweißtem I-Anker

Rundanker

HAC-C 28/15,
HAC-C 38/17,
HAC-C 40/25,
HAC-C 49/30,
HAC-C 54/33

Ankerschienen (HAC-C) mit Spezialschrauben (HBC)

Produktbeschreibung
Ankerschienentypen

Anhang A3

Kennzeichnung der Hilti Ankerschiene:

HAC-C(-T)(-P)(-I) X W Z

HAC	= Herstellerkennzeichen (H ilti A ncor C hannel)
T	= Zusätzliche Kennzeichnung für gezahnte Schienen
P	= Zusätzliche Kennzeichnung für Premium Variante
I	= Zusätzliche Kennzeichnung für I-Anker (keine Kennzeichnung für Rundanker)
X	= Größe der Schiene
W	= Schienenlänge
Z	= Korrosionsschutz/ Werkstoff (z.B. F für Feuerverzinkt, A4 oder A2 für Nichtrostender Stahl)

a)

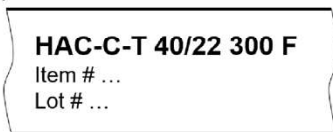

(Aufkleber und/oder Aufdruck mit Tinte z.B. auf der Rückseite der Schiene z.B. HAC-C-T 40/22 300 F)

HAC-C-T	= Gezahnte Ankerschiene
40/22 ¹⁾	= Ankerschienengröße 40/22
F	= Feuerverzinkt
300	= 300 mm Schienenlänge (l _{ch})

b)

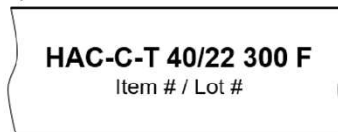

(Stempel innerhalb der Schiene, e.g. HAC-C-T 40/22 F)

Anmerkung: ¹⁾ Ankerschiene HAC-C-T 40/22 kann auch mit Kennzeichnung "38/23" ohne Änderung der Größe des Produktes hergestellt werden. Die 38/23 und 40/22 besitzen die gleichen Leistungen.

Kennzeichnung der Hilti Spezialschraube:

HBC(-T) X (-N) Y Z

HBC	= Herstellerkennzeichen (H ilti B olt C hannel)
T	= Zusätzliche Kennzeichnung für Zahnschraube
X	= Größe der Spezialschraube
N	= Zusätzliche Kennzeichnung für Kerbzahnschraube
Y	= Festigkeitsklasse (8.8, 70)
Z	= Korrosionsschutz/ Werkstoff (z.B. F)

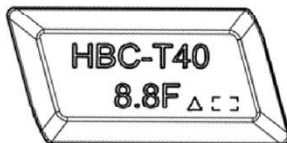

(Stempel auf der Rückseite der Schraube, z.B. HBC-T40 8.8F)

HBC-T	= Zahnschraube (für gezahnte Ankerschiene HAC-C-T)
40	= Größe der Spezialschraube (siehe Table 3)
8.8	= Festigkeitsklasse 8.8
F	= Feuerverzinkt

Ankerschienen (HAC-C) mit Spezialschrauben (HBC)

Produktbeschreibung
Kennzeichnung Ankerschiene und Spezialschrauben

Anhang A4

Schienenprofile

Warmgewalzte gezahnte Schienenprofile

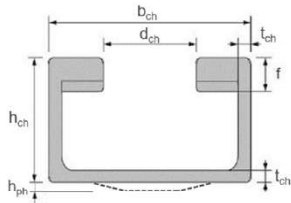

HAC-C-T 29/20,
HAC-C-T 40/22,
HAC-C-T 40L,
HAC-C-T 50/30,
HAC-C-T 50L,
HAC-C-T 53/34

Warmgewalzte glatte Schienenprofile

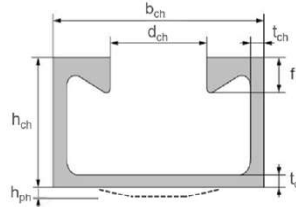

HAC-C(-P) 40/22,
HAC-C-P 40L,
HAC-C(-P) 50/30,
HAC-C-P 50L,
HAC-C 52/34

Kaltverformte glatte Schienenprofile

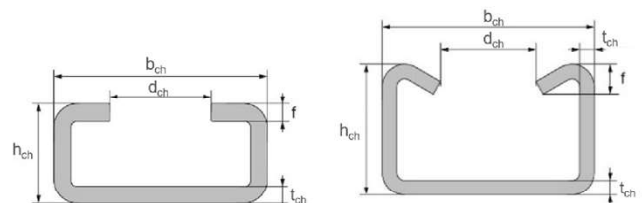

HAC-C 28/15,
HAC-C 38/17

HAC-C 40/25,
HAC-C 49/30,
HAC-C 54/33

Tabelle 1: Profilabmessungen der Schienenprofile

Ankerschiene	b _{ch}	h _{ch} ¹⁾	h _{ph} ¹⁾	t _{ch}	d _{ch}	f ²⁾	l _y
	[mm]						[mm ⁴]
Warmgewalzte HAC-C-T Ankerschiene							
HAC-C-T 29/20	30,4	20,0	1,6	3,2	14,0	5,35	11.832
HAC-C-T 40/22 HAC-C-T 40L	38,0	23,0	2,0	3,25	18,0	6,35	21.570
HAC-C-T 50/30 HAC-C-T 50L	50,0	30,0	2,5	3,4	22,5	7,3	58.546
HAC-C-T 53/34	53,5	34,0	4,0	4,5	22,5	8,50	100.900
Warmgewalzte HAC-C(-P) Ankerschiene							
HAC-C(-P) 40/22 HAC-C-P 40L	40,1	23,0	1,95	2,7	18,0	6,0	21.504
HAC-C(-P) 50/30 HAC-C-P 50L	49,6	30,0	2,5	3,2	22,5	8,1	57.781
HAC-C 52/34	52,5	34,0	-	4,0	22,5	11,5	97.606
Kaltverformte HAC-C Ankerschiene							
HAC-C 28/15	28,0	15,5	-	2,3	12,0	2,3	4.277
HAC-C 38/17	38,0	17,25	-	3,0	18,0	3,0	8.224
HAC-C 40/25	40,0	25,0	-	2,75	18,0	5,6	20.122
HAC-C 49/30	50,0	30,0	-	3,25	22,0	7,4	43.105
HAC-C 54/33	53,5	33,0	-	5,0	21,5	8,0	74.706

¹⁾ Für warmgewalzte gezahnte und glatte Ankerschienen – punktuelle Vergrößerung der Schienenhöhe (Höhe über den gestanzten Löchern) im Bereich des Ankers ist nicht im Maß h_{ch} berücksichtigt.

²⁾ Für warmgewalzte gezahnte Schienen (HAC-C-T) beinhaltet die Höhe der Schienenlippen die Höhe der Zähne;

Ankerschienen (HAC-C) mit Spezialschrauben (HBC)

Produktbeschreibung
Schienenprofile (HAC-C)

Anhang A5

Anker



Tabelle 2: Ankerabmessungen (Angeschweißter I-Anker oder Rundanker) ¹⁾

Ankerschiene	Rundanker					Angeschweißter I-Anker					
	min l_a	d_a	d_h	t_h	A_h	min l_a	t_w	b_h	t_h	W_A	A_h
	[mm]				[mm ²]	[mm]					[mm ²]
HAC-C-T (Warmgewalzte Ankerschiene)											
HAC-C-T 29/20	62,4	9,0	18,0	2,0	190,8	- ²⁾					
HAC-C-T 40/22	71,2	10,0	21,5	2,2	284,4	- ²⁾					
HAC-C-T 40L	87,2	10,0	21,5	2,2	284,4	- ²⁾					
HAC-C-T 50/30	101,5	11,0	26,0	2,5	435,9	- ²⁾					
HAC-C-T 50L	141,8	11,0	26,0	2,5	435,9	- ²⁾					
HAC-C-T 53/34	119,5	12,0	26,0	2,5	417,8	- ²⁾					
HAC-C-P (Warmgewalzte Ankerschiene)											
HAC-C 40/22	58,0	8,0	16,0	2,0	151,0	62,0	5,0	20,0	5,0	20,0	300,0
HAC-C-P 40/22	70,0	10,0	21,5	2,2	285,0	125,0	6,0	25,0	5,0	20,0	380,0
HAC-C-P 40L	83,2	10,0	21,5	2,2	285,0	- ²⁾					
HAC-C 50/30	66,0	10,0	20,0	2,2	236,0	69,0	5,0	20,0	5,0	25,0	375,0
HAC-C-P 50/30	78,0	11,0	26,0	2,5	436,0	125,0	6,0	25,0	5,0	25,0	475,0
HAC-C-P 50L	118,3	11,0	26,0	2,5	436,0	- ²⁾					
HAC-C 52/34	123,5	11,0	24,3	2,5	369,0	125,0	6,0	25,0	5,0	40,0	760,0
HAC-C (Kaltverformte Ankerschiene)											
HAC-C 28/15	31,0	6,0	12,0	1,3	85,0	- ²⁾					
HAC-C 38/17	60,8	8,0	16,0	2,0	151,0	- ²⁾					
HAC-C 40/25	56,0	8,0	16,0	2,0	151,0	- ²⁾					
HAC-C 49/30	66,0	10,0	20,0	2,2	236,0	- ²⁾					
HAC-C 54/33	124,5	11,0	24,3	2,5	369,0	- ²⁾					

¹⁾ Für kaltverformte Schienenprofile (und für HAC-C 52/34) – $h_{ph} = 0$ und Länge der Anker wie bei den angeschweißten I-Ankern ermittelt;

²⁾ Produkt nicht vorhanden

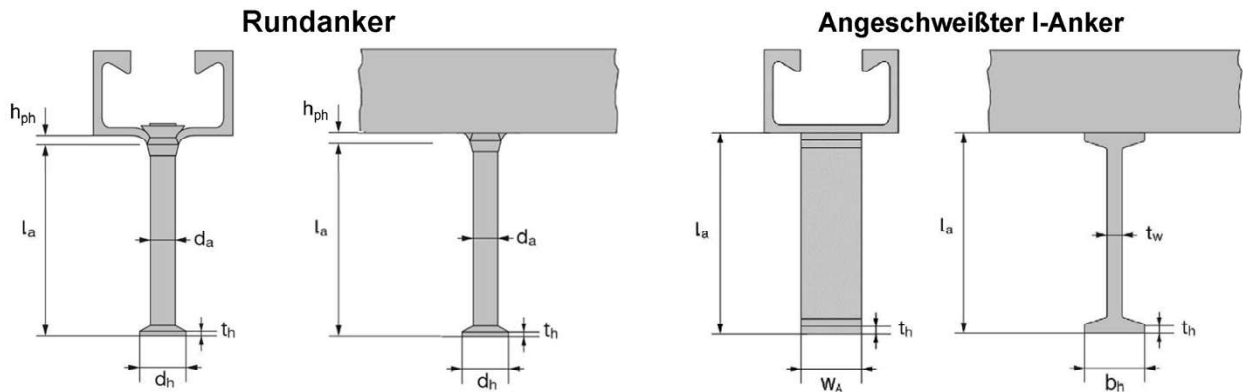
Ankerschienen (HAC-C) mit Spezialschrauben (HBC)

Produktbeschreibung
Anker

Anhang A6

Spezialschrauben

Tabelle 3: Abmessungen der Spezialschrauben

Ankerschiene	Spezial- schraube	Festig- keits- klasse 1)	Abmessungen			
			d	b _{cbo,1}	b _{cbo,2}	t _{cbo}
[mm]						
für warmgewalzte Schienen (HAC-C-T)						
HAC-C-T 29/20	HBC-T 29/20	8.8, A4-70	10	13,5	22,8	8,0
			12	13,5	22,8	8,0
HAC-C-T 40/22	HBC-T 40/22	8.8, A4-70	10	17,1	30,3	9,5
			12	17,1	30,3	9,5
			16	17,1	30,3	9,5
HAC-C-T 50/30	HBC-T 50/30	8.8, A4-70	16	21,0	42,0	13,8
HAC-C-T 53/34	HBC-T 50/30	8.8, A4-70	20	21,0	42,0	13,8
für warmgewalzte und/oder kaltverformte Schienen (HAC-C)						
HAC-C(-P) 40/22 HAC-C-P 40L HAC-C 40/25	HBC-40/22	8.8, A4-70	10	14,0	33,0	10,5
			12	14,0	33,0	11,5
			16	17,0	33,0	11,5
HAC-C-P 40/22 HAC-C-P 40L	HBC-40/22-N	8.8, A4-70	16	17,0	33,0	11,5
HAC-C 49/30 HAC-C(-P) 50/30 HAC-C-P 50L HAC-C 52/34 HAC-C 54/33	HBC-50/30	8.8, A4-70	12	17,0	42,0	14,5
			16	17,0	42,0	15,5
			20	21,0	42,0	15,5
HAC-C-P 50/30 HAC-C-P 50L HAC-C 52/34	HBC-50/30-N	8.8, A4-70	16	21,0	42,0	15,5
HAC-C-P 50/30 HAC-C-P 50L HAC-C 52/34	HBC-50/30-N	8.8, A4-70	20	21,0	42,0	15,5
für kaltverformte Schienen (HAC-C)						
HAC-C 38/17	HBC-38/17	8.8, A4-70	10	13,0	30,5	6,0
			12	13,0	30,5	7,0
			16	16,0	30,5	7,0
HAC-C 28/15	HBC-28/15	8.8, A4-70	8	10,1	22,2	5,0
			10	10,1	22,2	5,0
			12	11,0	22,2	8,0

1) Werkstoffeigenschaften gemäß Anhang A8

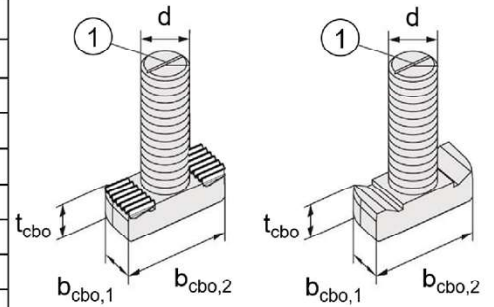

HBC-T 29/20,
HBC-T 40/22,
HBC-T 50/30

HBC-40/22;
HBC-50/30

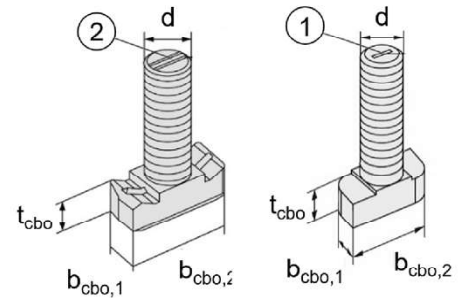

HBC-40/22-N,
HBC-50/30-N

HBC-28/15,
HBC-38/17

Anmerkung:
Kennzeichnung Lage der Schraube:
① - Einfacher Schlitz;
② - Doppelter Schlitz

Tabelle 4: Festigkeitsklasse und Korrosionsschutz

Schraube	Stahl 1) 2)	Nichtrostender Stahl 1) 3)
Steel grade	8.8	A4-70
f _{uk} [N/mm ²]	800 / 830	700
f _{yk} [N/mm ²]	640 / 660	450
Korrosionsschutz	G 4) ; F 5)	R

1) Werkstoffeigenschaften gemäß Anhang A8

2) Werkstoffeigenschaften gemäß EN ISO 898-1

3) Werkstoffeigenschaften gemäß EN ISO 3506-1

4) Galvanisch verzinkt

5) Feuerverzinkt

Ankerschienen (HAC-C) mit Spezialschrauben (HBC)

Produktbeschreibung
Spezialschrauben (HBC)

Anhang A7

Tabelle 5: Werkstoffe

Komponente	Stahl			Nichtrostender Stahl	
	Werkstoff- eigenschaften	Beschichtung		Werkstoff- eigenschaften	
1	2a	2b	2c	3	4
Schienenprofil	1.0038, 1.0044, 1.0045 gemäß EN 10025-1 1.0976, 1.0979 gemäß EN 10149-1	Feuerverzinkt $\geq 55 \mu\text{m}$ ³⁾ Feuerverzinkt $\geq 70 \mu\text{m}$ ⁴⁾ gemäß EN ISO 1461, Tabelle 3		1.4301 gemäß EN 10088-1 ³⁾	1.4362, 1.4401 1.4404, 1.4571, 1.4578 gemäß EN 10088-1 ³⁾
Anker	1.0038, 1.0213, 1.0214 gemäß EN 10025-1 1.5523, 1.5535 gemäß EN 10263-1				
Spezialschraube	Festigkeitsklasse 8.8 gemäß EN ISO 898-1	Galvanisch verzinkt gemäß EN ISO 4042	Feuerverzinkt $\geq 50 \mu\text{m}$ gemäß EN ISO 10684	Festigkeitsklasse 70 gemäß EN ISO 3506-1	
Unterlegscheibe ¹⁾ gemäß EN ISO 7089 und EN ISO 7093-1	Härteklasse A ≥ 200 HV	Galvanisch verzinkt gemäß EN ISO 4042	Feuerverzinkt \geq 50 μm gemäß EN ISO 10684	1.4401, 1.4404 1.4571, 1.4578 gemäß EN 10088-1	
Sechskantmutter gemäß EN ISO 4032 oder DIN 934	Klasse 8 gemäß EN ISO 898-2	Galvanisch verzinkt gemäß EN ISO 4042	Feuerverzinkt \geq 50 μm gemäß EN ISO 10684	Klasse 50, 70 or 80 gemäß EN ISO 3506-1	

¹⁾ Nur für Kerbzahnschrauben im Lieferumfang enthalten

²⁾ Anker aus Stahl gemäß Spalte 2a können auch verwendet werden, wenn sie angeschweißt sind und deren Betondeckung mehr als 50mm beträgt und die Anlauffarben entfernt sind

³⁾ Ankerschienen gemäß Tabelle 5 Spalte 3 sind mit "A2" gekennzeichnet und gemäß Spalte 4 mit "A4";

³⁾ für HAC-C-T 29/20; HAC-C(-P) 40/22, 40L; HAC-C 28/15, 38/17, 40/25, 49/30, 54/33;

⁴⁾ für HAC-C-T 53/34, 50/30, 50L, 40/22, 40L; HAC-C(-P) 50/30, 50L, 53/34.

Ankerschienen (HAC-C) mit Spezialschrauben (HBC)

Verwendungszweck
Werkstoffe

Anhang A8

Anwendungsbedingungen

Lebensdauer:

Der Nachweis und die Bewertungsmethoden, auf der diese Europäische Technische Bewertung basiert, führt zu der Annahme einer Lebensdauer von mindestens:

- 50 Jahren
(Ankerschienen und Spezialschrauben aus Stahl – gemäß Anhang A8, Spalten 2a-2c)
- 100 years
(Ankerschienen und Spezialschrauben aus nichtrostendem Stahl A4 – gemäß Anhang A8, Spalte 4)

Beanspruchung der Ankerschienen und Spezialschrauben:

- Statische und quasi-statische Zug und Querlast senkrecht zur Schienenlängsrichtung
- Statische und quasi-statische Querlast in Schienenlängsrichtung
(Ankerschienen HAC-C-P 40/22 und HAC-P 40L mit Kerbzahnschrauben HBC 40/22-N; Ankerschienen HAC-C-P 50/30 und HAC-C-P 50L mit Kerbzahnschrauben HBC 50/30-N und gezahnte Ankerschienen HAC-C-T mit Zahnschrauben HBC-T)
- Zyklische Ermüdungsbeanspruchung unter Zuglast
(Ankerschienen und Spezialschrauben gemäß Anhang C17)
- Seismische Zuglast, seismische Querlast senkrecht zur Schienenlängsrichtung und seismische Querlast in Schienenlängsrichtung (seismische Leistungskategorie C1)
(Ankerschienen und Spezialschrauben gemäß Anhang C19);
- Brandbeanspruchung: nur für Betonfestigkeitsklassen C20/25 bis C50/60 unter Zug und Querlast senkrecht zur Schienenlängsrichtung
(Ankerschienen und Spezialschrauben gemäß Anhang C23-C25)

Verankerungsgrund:

- Bewehrter oder unbewehrter verdichteter Normalbeton ohne Fasern gemäß EN 206.
- Festigkeitsklassen C12/15 bis C90/105 gemäß EN 206.
- Gerissener oder ungerissener Beton.

Anwendungsbedingungen (Umweltbedingungen):

- Bauteile unter den Bedingungen trockener Innenräume
(Ankerschienen und Spezialschrauben gemäß Anhang A8, Tabelle 5, Spalten 2 und 3).
- Bauteile unter den Bedingungen von Innenräumen mit normaler Luftfeuchte (z.B. Küchen, Bäder und Waschküchen in Wohngebäuden mit Ausnahme permanente Dampfeinwirkung und Anwendungen unter Wasser)
(Ankerschienen und Spezialschrauben gemäß Anhang A8, Tabelle 5, Spalten 2c und 3).
- Gemäß EN 1993-1-4 entsprechend der Korrosionsbeständigkeitsklasse CRC II
(Ankerschienen, Spezialschrauben, Scheiben, Muttern aus nichtrostendem Stahl 1.4401, 1.4404, 1.4571, 1.4362 und 1.4578 gemäß Anhang A8, Tabelle 5, Spalte 3).
- Gemäß EN 1993-1-4 entsprechend der Korrosionsbeständigkeitsklasse CRC III
(Ankerschienen, Spezialschrauben, Scheiben, Muttern aus nichtrostendem Stahl 1.4401, 1.4404, 1.4571, 1.4362 und 1.4578 gemäß Anhang A8, Tabelle 5, Spalte 4).

Ankerschienen (HAC-C) mit Spezialschrauben (HBC)

Verwendungszweck
Spezifikation

[Anhang B1](#)

Bemessung:

- Ankerschienen müssen unter der Verantwortung eines auf dem Gebiet der Verankerungen und des Betonbaus erfahrenen Ingenieurs bemessen werden.
- Unter Berücksichtigung der zu verankernden Lasten sind prüfbare Berechnungen und Konstruktionszeichnungen anzufertigen. Auf den Konstruktionszeichnungen ist die Lage der Ankerschienen und Spezialschrauben anzugeben (z.B. Lage der Ankerschiene zur Bewehrung oder zu den Auflagern).
- Die Bemessung von Ankerschienen unter statischer und quasi-statischer Belastung sowie Ankerschienen unter Brandbeanspruchung erfolgt gemäß EN 1992-4 und EOTA TR 047.
- Die Bemessung von Ankerschienen unter Ermüdungsbeanspruchung erfolgt gemäß EOTA TR 050.
- Die charakteristischen Widerstände sind mit der minimalen wirksamen Verankerungstiefe zu berechnen.

Einbau:

- Der Einbau der Ankerschienen erfolgt durch entsprechend geschultes Personal unter der Aufsicht des Bauleiters.
- Verwendung der Ankerschiene nur so, wie vom Hersteller geliefert, ohne Veränderungen, Umordnung oder Austausch einzelner Teile.
- Abschneiden der Ankerschienen, nur wenn Stücke einschließlich der Schienenüberstände und minimalen Schienenlängen gemäß Anhang B3, Tabelle 6 und Tabelle 7 sowie Anhang B4 Tabelle 8 erzeugt werden und für den Fall der feuerverzinkten Ankerschienen nur zur Verwendung in trockenen Innenräumen.
- Einbau nach der Montageanleitung des Herstellers gemäß Anhängen B7-B11.
- Die Ankerschienen sind so auf der Schalung, der Bewehrung oder Hilfskonstruktion zu fixieren, dass sie sich beim Verlegen der Bewehrung sowie beim Einbringen und Verdichten des Betons nicht bewegen.
- Einwandfreie Verdichtung des Betons unter dem Kopf der Anker. Die Schienen sind gegen Eindringen von Beton in den Schieneninnenraum geschützt.
- Unterlegscheiben können gemäß Anhang A6 gewählt und separat durch den Anwender bezogen werden.
- Ausrichtung der Spezialschrauben (Schlitz gemäß Anhang B8, B9 und B10) rechtwinklig zur Schienenachse.
- Sechskantschraube muss mit einem kalibrierten Drehmomentenschlüssel angezogen werden. Die erforderlichen Montagedrehmomente in Anhang B5 müssen aufgebracht werden und dürfen nicht überschritten werden.

Ankerschienen (HAC-C) mit Spezialschrauben (HBC)

Verwendungszweck
Spezifikation

[Anhang B2](#)

Tabelle 6: Montagekennwerte der HAC-C-T (gezahnten warmgewalzten) Ankerschienen

Ankerschiene		HAC-C-T 29/20			HAC-C-T 40/22		HAC-C-T 40L	HAC-C-T 50/30	HAC-C-T 50L	HAC-C-T 53/34
Minimale wirksame Verankerungstiefe	$h_{ef,min}$	82			94		110	108	148	155
Minimaler Achabstand	s_{min}	100	100	50	80	100	80	80	80	80
Maximaler Achabstand	s_{max}	200			250		250		250	
Endabstand	x	25 ²⁾			25 ²⁾		30 ²⁾		35	
Minimale Schienenlänge	l_{min}	150	150	100	130	150	130	140	140	170
Minimaler Randabstand	c_{min}	75	50	75	75	50	75	75	75	75
Minimale Bauteildicke	h_{min}	100	125	125	100	125	125	120	162	178
$h_{ef} + t_h + c_{nom}$ ¹⁾										

¹⁾ c_{nom} gemäß EN 1992-1-1

²⁾ Der Endabstand kann von 25 mm auf 35 mm vergrößert werden

Tabelle 7: Montagekennwerte der HAC-C-(P) (warmgewalzten) Ankerschienen

Ankerschiene		HAC-C 40/22	HAC-C-P 40/22	HAC-C-P 40L	HAC-C 50/30	HAC-C-P 50/30	HAC-C-P 50L	HAC-C 52/34	
Minimale wirksame Verankerungstiefe	$h_{ef,min}$	79	91	106	94	106	148	155	
Minimaler Achabstand	s_{min}	100	50	50	100	50 ³⁾	50	100	
Maximaler Achabstand	s_{max}	250							
Endabstand	x	25 ²⁾						35 ⁴⁾	
Minimale Schienenlänge	l_{min}	150	100	100	150	100	100	170 ⁵⁾	
Minimaler Randabstand	c_{min}	50			75			75	
Minimale Bauteldicke	h_{min}	100	100	120	105	120	162	165	
$h_{ef} + t_h + c_{nom}$ ¹⁾									

¹⁾ c_{nom} gemäß EN 1992-1-1

²⁾ Der Endabstand kann von 25 mm auf 35 mm vergrößert werden

³⁾ $s_{min} = 100$ mm in Kombination mit Kerbzahnschraube

⁴⁾ $x = 25$ mm für geschweißte I-Anker

⁵⁾ $l_{min} = 150$ mm für geschweißte I-Anker

Ankerschienen (HAC-C) mit Spezialschrauben (HBC)

Verwendungszweck
Montageparameter der Ankerschienen (HAC-C) mit Spezialschrauben (HBC)

[Anhang B3](#)

Tabelle 8: Montagekennwerte der HAC-C (kaltverformten) Ankerschienen

Ankerschiene		HAC-C 28/15	HAC-C 38/17	HAC-C 40/25	HAC-C 49/30	HAC-C 54/33
Minimale wirksame Verankerungstiefe	$h_{ef,min}$	45	76	79	94	155
Minimaler Achsabstand	s_{min}	50	100			
Maximaler Achsabstand	s_{max}	200		250		
Endabstand	x	25 ²⁾				
Minimale Schienenlänge	l_{min}	100	150			
Minimaler Randabstand	c_{min}	40	50	50	75	100
Minimale Bauteldicke	h_{min}	70	100	100	120	180
		$h_{ef} + t_h + c_{nom}$ ¹⁾				

¹⁾ c_{nom} gemäß EN 1992-1-1

²⁾ Der Endabstand kann von 25 mm auf 35 mm vergrößert werden



Tabelle 9: Minimaler Achsabstand der Spezialschrauben

Spezialschraube		M8	M10	M12	M16	M20
Minimaler Achsabstand der Spezialschrauben	$s_{cbo,min}$ [mm]	40	50	60	80	100

s_{cbo} = Achsabstand der Spezialschrauben ($s_{cbo,min} = 5d$)

Ankerschienen (HAC-C) mit Spezialschrauben (HBC)

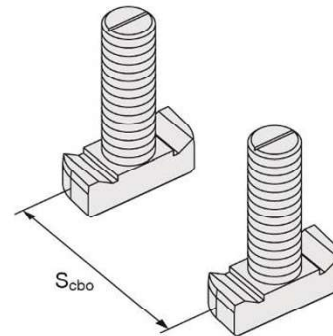
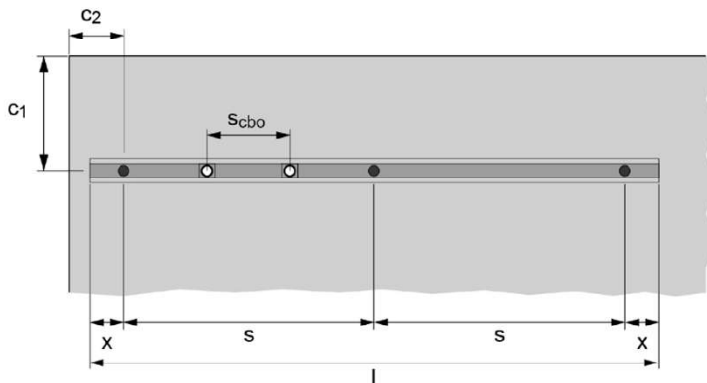
Verwendungszweck
Montageparameter der Ankerschienen (HAC-C) mit Spezialschrauben (HBC)

[Anhang B4](#)

Tabelle 10: Erforderliches Montagedrehmoment T_{inst}

Spezialschraube		Montagedrehmoment T_{inst} [Nm] ¹⁾		
		Allgemein: $T_{inst,g}$ [Nm]		Allgemein: $T_{inst,g}$ [Nm]
		8.8, A4-70	8.8	A4-70
Schrauben für warmgewalzte (HAC-C-T) Ankerschienen ²⁾				
HBC-T 29/20	M10	40	40	40
	M12	60	60	60
HBC-T 40/22	M10	40	40	40
	M12	60	60	60
	M16	100	100	100
HBC-T 50/30	M16	100	100	100
	M20	120	120	120
Schrauben für warmgewalzte und/oder kaltverformte (HAC-C) Ankerschienen ²⁾				
HBC 40/22	M10	15	- ³⁾	22
	M12	25	45	50
	M16	30	100	90
HBC 40/22-N	M16	30	160	- ³⁾
HBC 50/30	M12	25	45	50
	M16	60	100	130
	M20	75	360	250
HBC 50/30-N	M16	60	185	- ³⁾
	M20	75	320	- ³⁾
Schrauben für kaltverformte glatte (HAC-C) Ankerschienen ²⁾				
HBC 28/15	M8	7	20	15
	M10	10	40	30
	M12	13	60	50
HBC 38/17	M10	15	- ³⁾	22
	M12	25	45	50
	M16	40	100	90

¹⁾ T_{inst} darf nicht überschritten werden

²⁾ gemäß Tabelle 3

³⁾ Produkt nicht vorhanden

Ankerschienen (HAC-C) mit Spezialschrauben (HBC)

Verwendungszweck
Montagekennwerte der Spezialschrauben (HBC)

[Anhang B5](#)

Allgemein: Das Anbauteil ist in Kontakt mit dem Schienenprofil und der Betonoberfläche

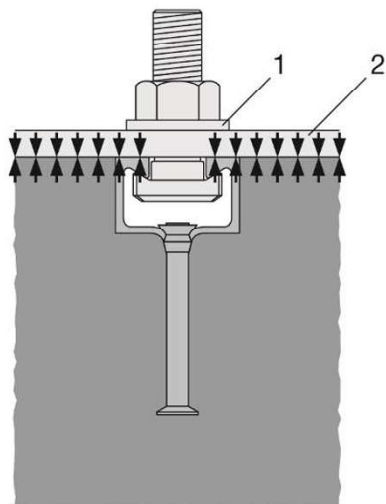

Stahl-Stahl Kontakt: Das Anbauteil ist nicht in Kontakt mit der Betonoberfläche. Das Anbauteil ist mit der Ankerschiene durch ein geeignetes Stahlteil (z.B. Unterlegescheibe) verspannt

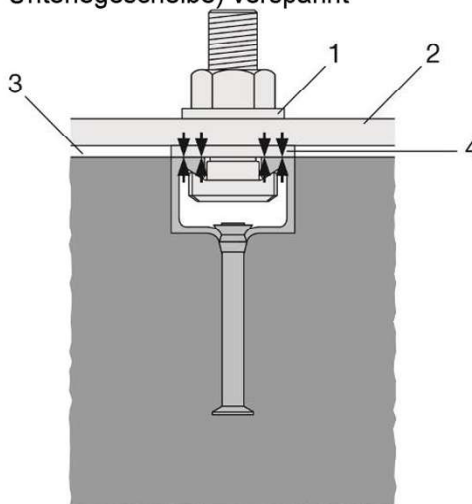

Legende

- 1 Unterlegscheibe
- 2 Anbauteil
- 3 Abstand
- 4 geeignetes Stahlteil

Ankerschienen (HAC-C) mit Spezialschrauben (HBC)

Verwendungszweck
Lage des Anbauteils

Anhang B6

HAC-C(-P)

2443751-11.2024

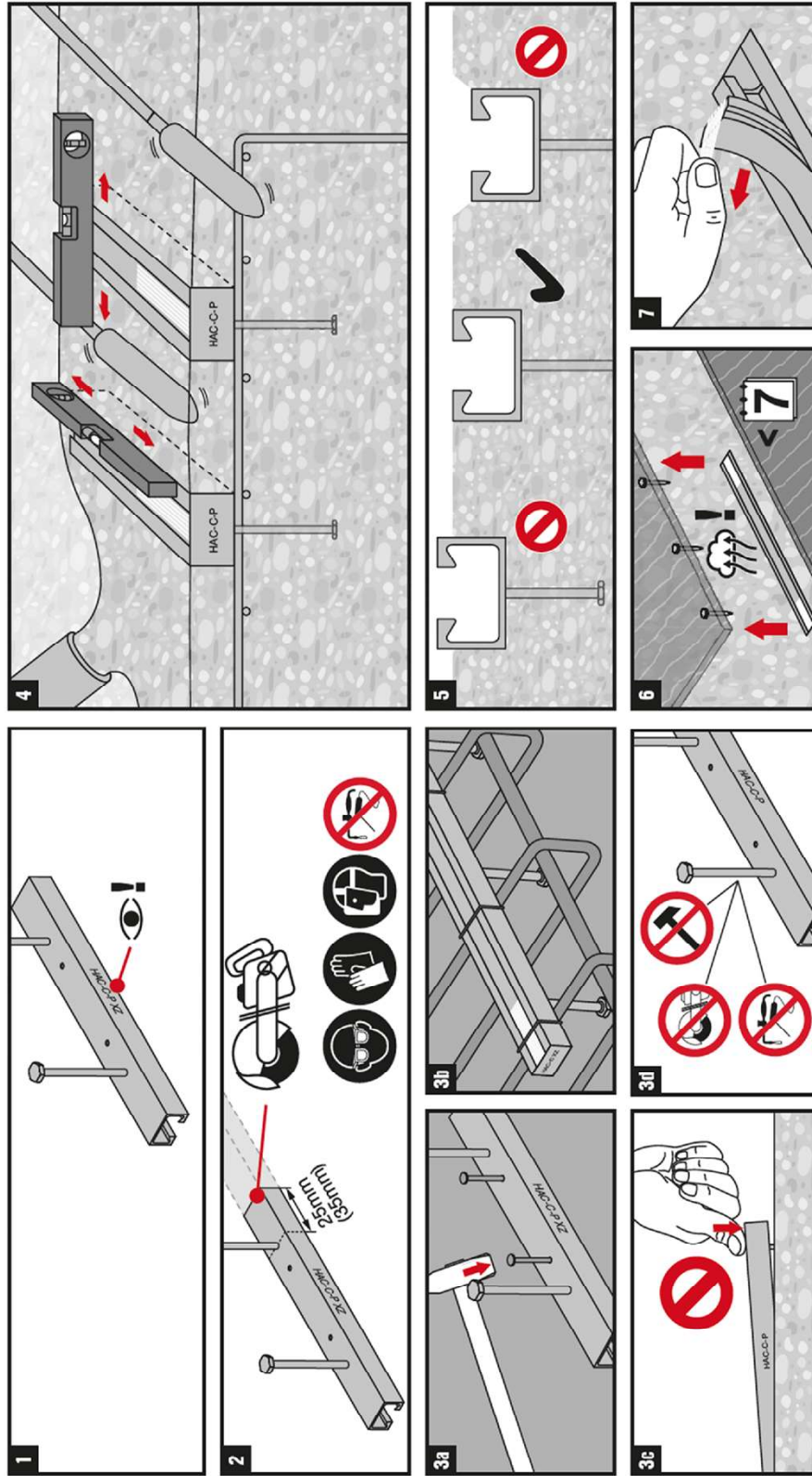

Ankerschienen (HAC-C) mit Spezialschrauben (HBC)

Verwendungszweck
Montageanleitung der Ankerschienen (HAC-C)

Anhang B7



HAC-C-T



2412857-04.2025

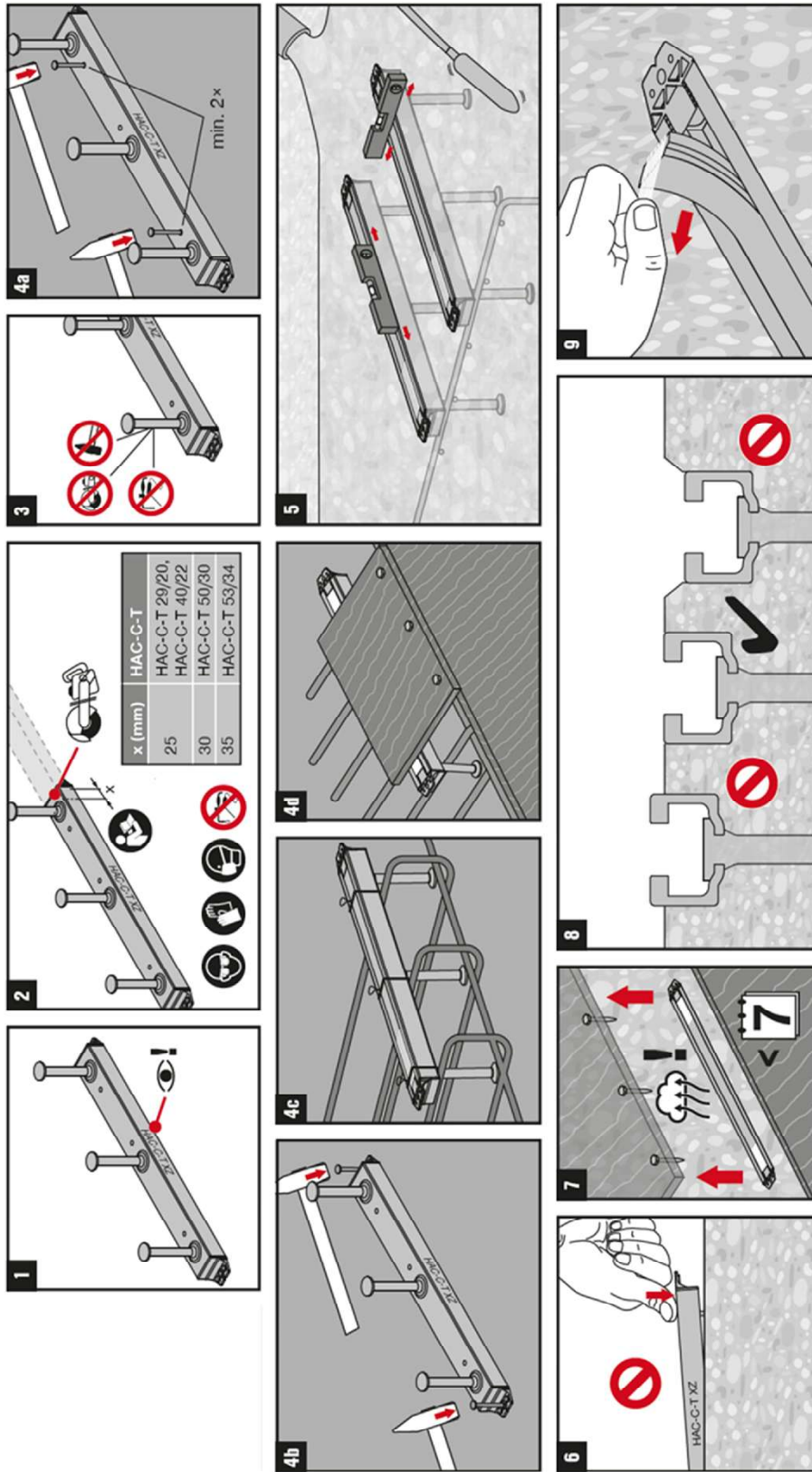

Ankerschienen (HAC-C) mit Spezialschrauben (HBC)

Verwendungszweck
Montageanleitung der Ankerschienen (HAC-C-T)

Anhang B8



HBC

2194125-09.2022

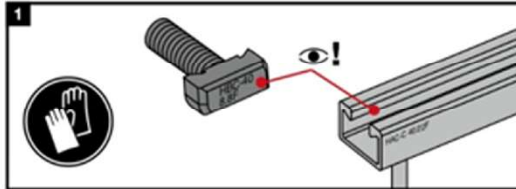

HBC-28/15	HAC-C 28/15
HBC-38/17	HAC-C 38/17
HBC-40/22	HAC-C-P 40/22, HAC-C-P 40L, HAC-C 40/22, HAC-C 40/25
HBC-50/30	HAC-C-P 50/30, HAC-C-P 50L, HAC-C 49/30, HAC-C 50/30
HBC-52/34	HAC-C 52/34, HAC-C 54/33
	HAC-HW53, HAC-C 52/34

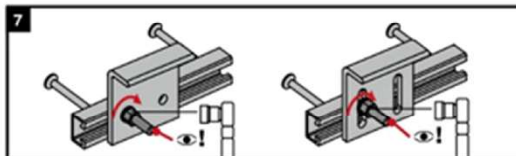
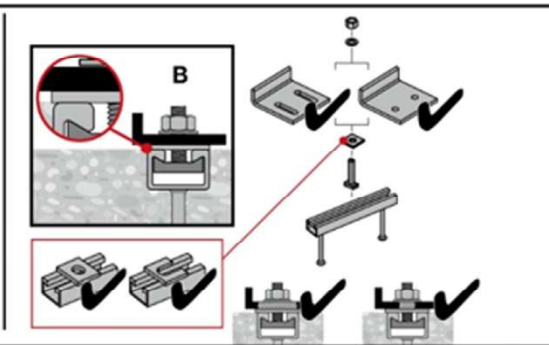
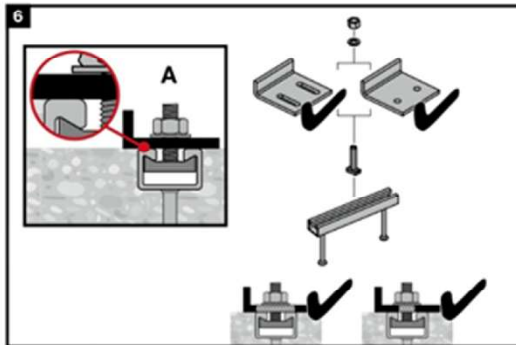
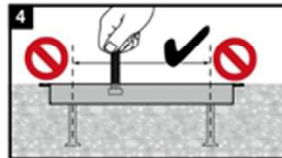
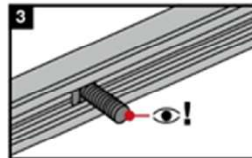
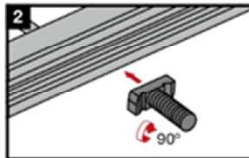

Channel bolt		T _{inst} [Nm]			
		A		B	
		8.8, A4-70	8.8	8.8	A4-70
HBC-28/15	M8	7		20	15
	M10	10		40	30
	M12	13		60	50
HBC-38/17	M10	15		15	22
	M12	25		45	50
	M16	40		100	90
HBC-40/22	M10	15		15	22
	M12	25		45	50
	M16	30		100	90
HBC-50/30	M12	25		45	50
	M16	55		100	130
	M20	55		360	250
HBC-52/34	M20	55		360	-

T_{inst} darf nicht überschritten werden

Ankerschienen (HAC-C) mit Spezialschrauben (HBC)

Verwendungszweck
Montageanleitung der Spezialschrauben (HBC)

Anhang B9



HBC-N

2257118-09.2022

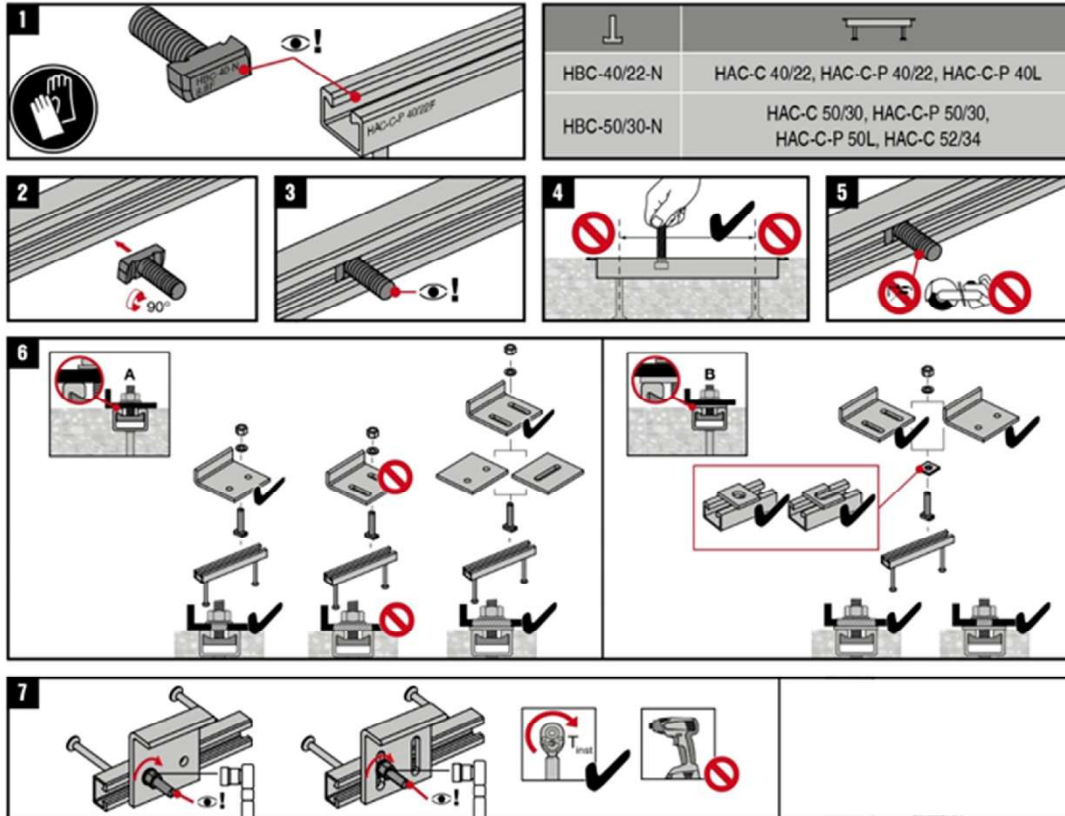

Anchor Channel	Channel Bolt	T_{inst} [Nm]	
		A	B
HAC-C-P 40/22	HBC-40/22-N M16	8,8	8,8
HAC-C-P 40L		160	160
HAC-C 40/22		60	160
HAC-C-P 50/30	HBC-50/30-N M16	185	185
HAC-C-P 50L		185	185
HAC-C 50/30		185	185
HAC-C 52/34	HBC-50/30-N M20	320	320
HAC-C-P 50/30		320	320
HAC-C-P 50L		320	320
HAC-C 50/30		320	320
HAC-C 52/34			

T_{inst} darf nicht überschritten werden

Ankerschienen (HAC-C) mit Spezialschrauben (HBC)

Verwendungszweck
Montageanleitung der Kerbzahnschrauben (HBC-N)

Anhang B10



HBC-T



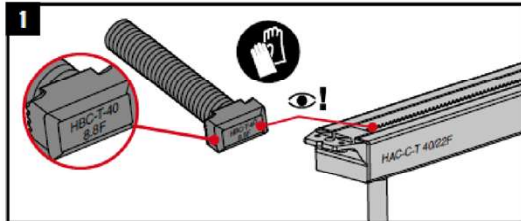

2412973-05.2025

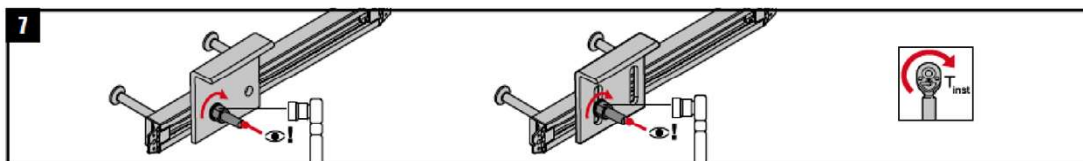
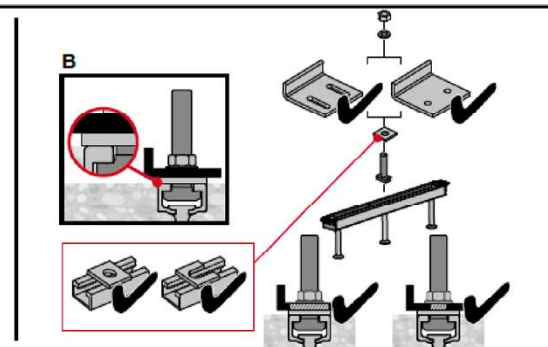
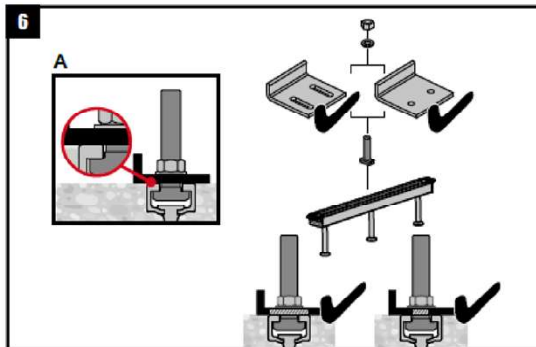
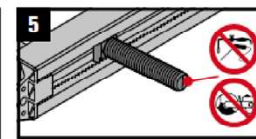
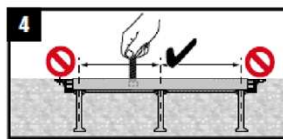
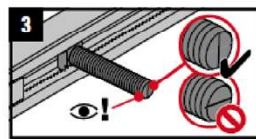
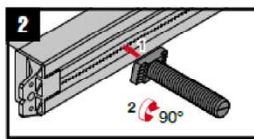

T-bolt	Channel
HBC-T-29/20	HAC-C-T 29/20
HBC-T-40/22	HAC-C-T 40/22
HBC-T-50/30	HAC-C-T 50/30
	HAC-C-T 53/34

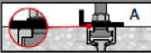
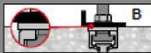

Channel bolt		 	
		T_{inst} [Nm] 	
		8.8 / A4-70	
HBC-T-29/20	M10	40	
	M12	60	
HBC-T-40/22	M10	40	
	M12	60	
	M16	100	
HBC-T-50/30	M16	100	
	M20	120	

T_{inst} darf nicht überschritten werden

Ankerschienen (HAC-C) mit Spezialschrauben (HBC)

Verwendungszweck
Montageanleitung der Zahnschrauben (HBC-T)

Anhang B11

Tabelle 11: Charakteristische Widerstände unter Zuglast – Stahlversagen der HAC-C-T (gezahnten warmgewalzten) Ankerschienen

Ankerschiene				HAC-C-T 29/20	HAC-C-T 40/22	HAC-C-T 40L	HAC-C-T 50/30	HAC-C-T 50L	HAC-C-T 53/34
Stahlversagen: Anker									
Charakteristischer Widerstand	Stahl	$N_{Rk,s,a}$	[kN]	35,0	41,0		57,0		73,5
	Nichtrostender Stahl				45,0				
Teilsicherheitsbeiwert		$\gamma_{Ms}^{1)}$	[-]	1,8					
Stahlversagen: Verbindung zwischen Anker und Schiene									
Charakteristischer Widerstand	Stahl	$N_{Rk,s,c}$	[kN]	33,0	40,0	55,0			73,5
	Nichtrostender Stahl			35,0	42,0	60,0			
Teilsicherheitsbeiwert		$\gamma_{Ms,ca}^{1)}$	[-]	1,8					
Stahlversagen: Aufbiegen der Schienenlippe									
Teilsicherheitsbeiwert $N_{Rk,s,l}$		$s_{i,N}$	[mm]	61	76	100		107	
Charakteristischer Widerstand	Stahl	$N^0_{Rk,s,l}$	[kN]	35,0	45,0		64,0		85,0
	Nichtrostender Stahl				42,0				
Teilsicherheitsbeiwert		$\gamma_{Ms,l}^{1)}$	[-]	1,8					

¹⁾ Sofern andere nationale Regelungen fehlen

Tabelle 12: Charakteristische Widerstände unter Zuglast – Stahlversagen der HAC-C-(P) (glatten warmgewalzten) Ankerschienen

Ankerschiene				HAC-C 40/22	HAC-C-P 40/22	HAC-C-P 40L	HAC-C 50/30	HAC-C-P 50/30	HAC-C-P 50L	HAC-C 52/34
Stahlversagen: Anker										
Charakteristischer Widerstand		$N_{Rk,s,a}$	[kN]	20,0	40,0	40,0	31,0	57,0	57,0	55,0
Teilsicherheitsbeiwert		$\gamma_{Ms}^{1)}$	[-]	1,8						
Stahlversagen: Verbindung zwischen Anker und Schiene										
Charakteristischer Widerstand		$N_{Rk,s,c}$	[kN]	20,0	39,6	39,6	31,0	50,6	50,6	55
Teilsicherheitsbeiwert		$\gamma_{Ms,ca}^{1)}$	[-]	1,8						
Stahlversagen: Aufbiegen der Schienenlippe										
Charakteristischer Achsabstand der Spezialschrauben für $N_{Rk,s,l}$		$s_{i,N}$	[mm]	79	79	79	98	98	98	105
Charakteristischer Widerstand		$N^0_{Rk,s,l}$	[kN]	47,9	47,9	47,9	50,5	50,5	50,5	65,0
Teilsicherheitsbeiwert		$\gamma_{Ms,l}^{1)}$	[-]	1,8						

¹⁾ Sofern andere nationale Regelungen fehlen.

Ankerschienen (HAC-C) mit Spezialschrauben (HBC)

Leistung

Charakteristische Widerstände der Ankerschienen (HAC-C) unter Zuglast - Stahlversagen

Anhang C1

Tabelle 13: Charakteristische Widerstände unter Zuglast – Stahlversagen der HAC-C (kaltverformten) Ankerschienen

Ankerschiene			HAC-C 28/15	HAC-C 38/17	HAC-C 40/25	HAC-C 49/30	HAC-C 54/33
Stahlversagen: Anker							
Charakteristischer Widerstand	$N_{RK,s,a}$	[kN]	9,0	18,0	20,0	31,0	55,0
Teilsicherheitsbeiwert	$\gamma_{Ms}^{1)}$	[-]	1,8				
Stahlversagen: Verbindung zwischen Anker und Schiene							
Charakteristischer Widerstand	$N_{RK,s,c}$	[kN]	9,0	18,0	20,0	31,0	55,0
Teilsicherheitsbeiwert	$\gamma_{Ms,ca}^{1)}$	[-]	1,8				
Stahlversagen: Aufbiegen der Schienenlippe							
Charakteristischer Achsabstand der Spezialschrauben für $N_{RK,s,l}$	$s_{i,N}$	[mm]	56	76	80	100	107
Charakteristischer Widerstand	$N_{RK,s,l}^0$	[kN]	9,0	18,0	20,0	31,0	55,0
Teilsicherheitsbeiwert	$\gamma_{Ms,l}^{1)}$	[-]	1,8				

¹⁾ Sofern andere nationale Regelungen fehlen.

Ankerschienen (HAC-C) mit Spezialschrauben (HBC)

Leistung

Charakteristische Widerstände der Ankerschienen (HAC-C) unter Zuglast -
Stahlversagen

Anhang C2

Tabelle 14: Charakteristischer Biege­widerstand der HAC-C-T (gezahnten warmgewalzten) Schienen unter Zuglast

Ankerschiene				HAC-C-T 29/20	HAC-C-T 40/22	HAC-C-T 40 L	HAC-C-T 50/30	HAC-C-T 50L	HAC-C-T 53/34
Stahlversagen: Biegung der Schiene									
Charakteristischer Biege­widerstand der Schiene	Stahl	$M_{Rk,s,flex}$	[Nm]	977	1557		3256		4870
	Nichtrostender Stahl			1100	1754		3366		4626
Teilsicherheitsbeiwert		$\gamma_{Ms,flex}$ ¹⁾	[-]	1,15					

¹⁾ Sofern andere nationale Regelungen fehlen.

Tabelle 15: Charakteristischer Biege­widerstand der HAC-C(-P) (warmgewalzten) Schienen unter Zuglast

Ankerschiene				HAC-C 40/22	HAC-C-P 40/22	HAC-C-P 40L	HAC-C 50/30	HAC-C-P 50/30	HAC-C-P 50L	HAC-C 52/34
Stahlversagen: Biegung der Schiene										
Charakteristischer Biege­widerstand der Schiene	Stahl	$M_{Rk,s,flex}$	[Nm]	1013	1704	1704	2084	3448	3448	3435
	Nichtrostender Stahl									
Teilsicherheitsbeiwert		$\gamma_{Ms,flex}$ ¹⁾	[-]	1,15						

¹⁾ Sofern andere nationale Regelungen fehlen.

Tabelle 16: Charakteristischer Biege­widerstand der HAC-C (kaltverformten) Schienen unter Zuglast

Ankerschiene				HAC-C 28/15	HAC-C 38/17	HAC-C 40/25	HAC-C 49/30	HAC-C 54/33
Stahlversagen: Biegung der Schiene								
Charakteristischer Biege­widerstand der Schiene	Stahl	$M_{Rk,s,flex}$	[Nm]	316	538	979	1669	2929
	Nichtrostender Stahl				527		1702	2832
Teilsicherheitsbeiwert		$\gamma_{Ms,flex}$ ¹⁾	[-]	1,15				

¹⁾ Sofern andere nationale Regelungen fehlen.

Ankerschienen (HAC-C) mit Spezialschrauben (HBC)

Leistung
Charakteristische Widerstände der Ankerschienen (HAC-C) unter Zuglast -
Stahlversagen

Anhang C3

Tabelle 17: Charakteristische Widerstände unter Zuglast – Betonversagen der HAC-C-T (gezahnten warmgewalzten) Ankerschienen

Ankerschiene				HAC-C-T 29/20	HAC-C-T 40/22	HAC-C-T 40L	HAC-C-T 50/30	HAC-C-T 50L	HAC-C-T 53/34
Ankertyp ²⁾				R	R	R	R	R	R
Betonversagen: Herausziehen									
Charakteristischer Widerstand in gerissenem Beton C12/15		N _{Rk,p}	[kN]	17,2	25,6		39,2		37,6
Charakteristischer Widerstand in ungerissenem Beton C12/15				24,0	35,8		54,9		52,6
Faktor für N _{Rk,p} = N _{Rk,p(C12/15)} · Ψ _c	C16/20	Ψ _c	[-]	1,33					
	C20/25			1,67					
	C25/30			2,08					
	C30/37			2,50					
	C35/45			2,92					
	C40/50			3,33					
	C45/55			3,75					
	C50/60			4,17					
	C55/67			4,58					
≥C60/75	5,00								
Teilsicherheitsbeiwert		γ _{Mp} = γ _{Mc} ¹⁾	[-]	1,5					
Betonversagen: Betonausbruch									
Produktfaktor k ₁	gerissener	k _{cr,N}	[-]	7,9	8,1	8,3	8,2	8,6	8,7
	unge- rissener	k _{ucr,N}	[-]	11,3	11,5	11,8	11,8	12,3	12,4
Teilsicherheitsbeiwert		γ _{Mc} ¹⁾	[-]	1,5					
Betonversagen: Spalten									
Charakteristischer Randabstand		s _{cr,sp}	[mm]	246	282	330	324	444	465
Charakteristischer Achsabstand		s _{cr,sp}	[mm]	492	564	660	648	888	930
Teilsicherheitsbeiwert		γ _{Msp} = γ _{Mc} ¹⁾	[-]	1,5					

¹⁾ Sofern andere nationale Regelungen fehlen.

²⁾ Ankertyp gemäß Anhang A3 und A6

Ankerschienen (HAC-C) mit Spezialschrauben (HBC)

Leistung

Charakteristische Widerstände der Ankerschienen (HAC-C-T) unter Zuglast -
Betonversagen

Anhang C4

Tabelle 18: Charakteristische Widerstände unter Zuglast – Betonversagen der HAC-C-(P) (warmgewalzten) Ankerschienen

Ankerschiene			HAC-C 40/22		HAC-C-P 40/22		HAC-C-P 40L		HAC-C 50/30		HAC-C-P 50/30		HAC-C-P 50L		HAC-C 52/34		
			I	R	I	R	I	R	I	R	I	R	I	R	I	R	
Ankertyp³⁾																	
Betonversagen: Herausziehen																	
Charakteristischer Widerstand in gerissenem Beton C12/15		$N_{Rk,p}$	[kN]	27,0	13,6	34,2	25,6	- ¹⁾	25,6	33,8	21,2	42,8	39,2	- ¹⁾	39,2	68,4	33,2
Charakteristischer Widerstand in ungerissenem Beton C12/15				37,8	19,0	47,9	35,8	- ¹⁾	35,8	47,3	29,7	59,9	54,9	- ¹⁾	54,9	95,8	46,5
Faktor für $N_{Rk,p} = N_{Rk,p(C12/15)} \cdot \Psi_c$	C16/20	Ψ_c	[-]	1,33													
	C20/25			1,67													
	C25/30			2,08													
	C30/37			2,50													
	C35/45			2,92													
	C40/50			3,33													
	C45/55			3,75													
	C50/60			4,17													
	C55/67			4,58													
	≥C60/75			5,00													
Teilsicherheitsbeiwert		$\gamma_{Mp} = \gamma_{Mc}^{2)}$	[-]	1,5													
Betonversagen: Betonausbruch																	
Produktfaktor k_1	gerissener	$k_{cr,N}$	[-]	7,9	8,0	8,2	8,1	8,2	8,6	8,7							
	unge-rissener	$k_{ucr,N}$	[-]	11,2	11,5	11,7	11,6	11,7	12,3	12,4							
Teilsicherheitsbeiwert		$\gamma_{Mc}^{2)}$	[-]	1,5													
Betonversagen: Spalten																	
Charakteristischer Randabstand		$c_{cr,sp}$	[mm]	237	273	318	282	318	444	465							
Charakteristischer Achsabstand		$s_{cr,sp}$	[mm]	474	546	636	564	636	888	930							
Teilsicherheitsbeiwert		$\gamma_{Mp} = \gamma_{Mc}^{2)}$	[-]	1,5													

¹⁾ Produkt nicht vorhanden

²⁾ Sofern andere nationale Regelungen fehlen

³⁾ Ankertyp gemäß Anhang A3 und A6

Ankerschienen (HAC-C) mit Spezialschrauben (HBC)

Leistung

Charakteristische Widerstände der Ankerschienen (HAC-C) unter Zuglast-Betonversagen

Anhang C5

Tabelle 19: Charakteristische Widerstände unter Zuglast – Betonversagen der HAC-C (kaltverformten) Ankerschienen

Ankerschiene				HAC-C 28/15	HAC-C 38/17	HAC-C 40/25	HAC-C 49/30	HAC-C 54/33
Ankertyp²⁾				R	R	R	R	R
Betonversagen: Herausziehen								
Charakteristischer Widerstand in gerissenem Beton C12/15		N _{Rk,p}	[kN]	7,6	13,6	13,6	21,2	33,2
Charakteristischer Widerstand in ungerissenem Beton C12/15				10,7	19,0	19,0	29,7	46,5
Faktor für N _{Rk,p} = N _{Rk,p(C12/15)} · Ψ _c	C16/20	Ψ _c	[-]	1,33				
	C20/25			1,67				
	C25/30			2,08				
	C30/37			2,50				
	C35/45			2,92				
	C40/50			3,33				
	C45/55			3,75				
	C50/60			4,17				
	C55/67			4,58				
≥C60/75	5,00							
Teilsicherheitsbeiwert		γ _{Mp} = γ _{Mc} ¹⁾	[-]	1,5				
Betonversagen: Betonausbruch								
Produktfaktor k ₁	gerissener	k _{cr,N}	[-]	7,2	7,8	7,9	8,1	8,7
	ungerissener	k _{ucr,N}	[-]	10,3	11,2	11,2	11,6	12,4
Teilsicherheitsbeiwert		γ _{Mc} ¹⁾	[-]	1,5				
Betonversagen: Spalten								
Charakteristischer Randabstand		c _{cr,sp}	[mm]	135	228	237	282	465
Charakteristischer Achsabstand		s _{cr,sp}	[mm]	270	456	474	564	930
Teilsicherheitsbeiwert		γ _{Msp} = γ _{Mc} ¹⁾	[-]	1,5				

¹⁾ Sofern andere nationale Regelungen fehlen

²⁾ Ankertyp gemäß Anhang A3 und A6

Ankerschienen (HAC-C) mit Spezialschrauben (HBC)

Leistung

Charakteristische Widerstände der Ankerschienen (HAC-C) unter Zuglast - Betonversagen

Anhang C6

Tabelle 20: Verschiebungen der HAC-C-T (gezahnten warmgewalzten) Ankerschienen unter Zuglast

Ankerschiene				HAC-C-T 29/20	HAC-C-T 40/22	HAC-C-T 40L	HAC-C-T 50/30	HAC-C-T 50L	HAC-C-T 53/34
Zuglast	Stahl	N	[kN]	14,8	20,1	20,1	34,6	34,6	50,8
	Nichtrostender Stahl			17,3	21,0	21,0	37,3	37,3	50,2
Kurzzeit- verschiebung ¹⁾	Stahl	δ_{N0}	[mm]	0,9	1,5	1,5	1,2	1,2	1,8
	Nichtrostender Stahl			0,9	1,5	1,5	1,7	1,7	1,6
Langzeit- verschiebung ¹⁾	Stahl	$\delta_{N\infty}$	[mm]	1,8	3,0	3,0	2,4	2,4	3,6
	Nichtrostender Stahl			1,8	3,0	3,0	3,4	3,4	3,2

¹⁾ Verschiebung in der Mitte zwischen zwei Ankern der Ankerschiene, einschließlich Schlupf der Schraube, Schienenlippenverformung, Biegung der Schiene und Schlupf der Ankerschiene im Beton.

Tabelle 21: Verschiebungen der (warmgewalzten) HAC-C(-P) Ankerschienen unter Zuglast

Ankerschiene				HAC-C 40/22	HAC-C-P 40/22	HAC-C-P 40L	HAC-C 50/30	HAC-C-P 50/30	HAC-C-P 50L	HAC-C 52/34
Zuglast	N	[kN]		13,9	15,3	15,3	14,3	25,8	25,8	25,8
Kurzzeit-verschiebung ¹⁾	δ_{N0}	[mm]		2,3	1,1	1,1	2,2	1,4	1,4	1,4
Langzeit-verschiebung ¹⁾	$\delta_{N\infty}$	[mm]		4,6	2,2	2,2	4,4	2,8	2,8	2,8

¹⁾ Verschiebung in der Mitte zwischen zwei Ankern der Ankerschiene, einschließlich Schlupf der Schraube, Schienenlippenverformung, Biegung der Schiene und Schlupf der Ankerschiene im Beton.

Tabelle 22: Verschiebungen der (kaltverformten) HAC-C Ankerschienen unter Zuglast

Ankerschiene				HAC-C 28/15	HAC-C 38/17	HAC-C 40/25	HAC-C 49/30	HAC-C 54/33
Zuglast	N	[kN]		3,6	7,1	7,9	12,3	21,8
Kurzzeit-verschiebung ¹⁾	δ_{N0}	[mm]		0,6	1,3	1,4	1,4	1,6
Langzeit-verschiebung ¹⁾	$\delta_{N\infty}$	[mm]		1,2	2,6	2,8	2,8	3,2

¹⁾ Verschiebung in der Mitte zwischen zwei Ankern der Ankerschiene, einschließlich Schlupf der Schraube, Schienenlippenverformung, Biegung der Schiene und Schlupf der Ankerschiene im Beton.

Ankerschienen (HAC-C) mit Spezialschrauben (HBC)

Leistung
Verschiebungen unter Zuglast.

Anhang C7

Tabelle 23: Charakteristische Widerstände unter Querlast – Stahlversagen der HAC-C-T (gezahnten warmgewalzten) Ankerschienen

Ankerschiene				HAC-C-T 29/20	HAC-C-T 40/22	HAC-C-T 40L	HAC-C-T 50/30	HAC-C-T 50L	HAC-C-T 53/34
Stahlversagen: Anker									
Charakteris- tischer Widerstand	Stahl	$V_{Rk,s,a,y}$	[kN]	37,0	52,0		80,0		120,0
	Nichtrostender Stahl				49,5		100,0		
Charakteris- tischer Widerstand	Stahl	$V_{Rk,s,a,x}$	[kN]	22,9	24,7		37,1		44,1
	Nichtrostender Stahl				28,3				
Teilsicherheits- beiwert	Stahl	$\gamma_{Ms}^{1)}$	[-]	1,5					
	Nichtrostender Stahl								
Stahlversagen: Verbindung zwischen Anker und Schiene									
Charakteris- tischer Widerstand	Stahl	$V_{Rk,s,c,y}$	[kN]	37,0	52,0		80,0		120,0
	Nichtrostender Stahl				49,5		100,0		
Charakteris- tischer Widerstand	Stahl	$V_{Rk,s,c,x}$	[kN]	19,8	24,0		33,0		44,1
	Nichtrostender Stahl			21,0	25,2		36,0		
Teilsicherheitsbeiwert		$\gamma_{Ms}^{1)}$	[-]	1,8					
Stahlversagen: Aufbiegen der Schienenlippe unter Querlast senkrecht zur Schienenlängsrichtung									
Charakteristischer Achsabstand der Spezialschrauben für $V_{Rk,s,l}$		$s_{l,v}$	[mm]	61,0	76,0		100,0		107,0
Charakteris- tischer Widerstand	Stahl	$V^0_{Rk,s,l,y}$	[kN]	37,0	52,0		80,0		120,0
	Nichtrostender Stahl				49,5		100,0		
Teilsicherheitsbeiwert		$\gamma_{Ms,l}^{1)}$	[-]	1,8					

¹⁾ Sofern andere nationale Regelungen fehlen

Ankerschienen (HAC-C) mit Spezialschrauben (HBC)

Leistung

Charakteristische Widerstände der Ankerschienen (HAC-C) unter Querlast-
Stahlversagen

Anhang C8

Tabelle 24: Charakteristische Widerstände unter Querlast – Stahlversagen der HAC-C(-P) (warmgewalzten) Ankerschienen

Ankerschiene			HAC-C 40/22	HAC-C-P 40/22	HAC-C-P 40L	HAC-C 50/30	HAC-C-P 50/30	HAC-C-P 50L	HAC-C 52/34
Stahlversagen: Anker									
Char. Widerstand	$V_{Rk,s,a,y}$	[kN]	26,0	58,1	58,1	40,3	100,0	100,0	121,5
Char. Widerstand	$V_{Rk,s,a,x}$	[kN]	- ²⁾	24,0	24,0	- ²⁾	34,2	34,2	33,1
Teilsicherheitsbeiwert	γ_{Ms} ¹⁾	[-]	1,5						
Stahlversagen: Verbindung zwischen Anker und Schiene									
Char. Widerstand	$V_{Rk,s,c,y}$	[kN]	26,0	58,1	58,1	40,3	100,0	100,0	121,5
Char. Widerstand	$V_{Rk,s,c,x}$	[kN]	- ²⁾	23,8	23,8	- ²⁾	30,4	30,4	28,1
Teilsicherheitsbeiwert	$\gamma_{Ms,ca}$ ¹⁾	[-]	1,8						
Stahlversagen: Aufbiegen der Schienenlippe unter Querlast senkrecht zur Schienenlängsrichtung									
Charakteristischer Achsabstand der Spezialschrauben für $V_{Rk,s,l}$	$s_{l,v}$	[mm]	80	80	80	99	99	99	105
Char. Widerstand	$V^0_{Rk,s,l,y}$	[kN]	55,0	55,0	55,0	91,7	91,7	91,7	71,5
Teilsicherheitsbeiwert	$\gamma_{Ms,l}$ ¹⁾	[-]	1,8						

¹⁾ Sofern andere nationale Regelungen fehlen

²⁾ Leistung nicht bewertet

Tabelle 25: Charakteristische Widerstände unter Querlast – Stahlversagen der HAC-C (kaltverformten) Ankerschienen

Ankerschiene			HAC-C 28/15	HAC-C 38/17	HAC-C 40/25	HAC-C 49/30	HAC-C 54/33
Stahlversagen: Anker							
Char. Widerstand	$V_{Rk,s,a,y}$	[kN]	9,0	18,0	20,0	31,0	55,0
Teilsicherheitsbeiwert	γ_{Ms} ¹⁾	[-]	1,5				
Stahlversagen: Verbindung zwischen Anker und Schiene							
Char. Widerstand	$V_{Rk,s,c,y}$	[kN]	9,0	18,0	20,0	31,0	55,0
Teilsicherheitsbeiwert	$\gamma_{Ms,ca}$ ¹⁾	[-]	1,8				
Stahlversagen: Aufbiegen der Schienenlippe unter Querlast senkrecht zur Schienenlängsrichtung							
Charakteristischer Achsabstand der Spezialschrauben für $V_{Rk,s,l}$	$s_{l,v}$	[mm]	56	76	80	100	107
Char. Widerstand	$V^0_{Rk,s,l,y}$	[kN]	9,0	18,0	20,0	31,0	55,0
Teilsicherheitsbeiwert	$\gamma_{Ms,l}$ ¹⁾	[-]	1,8				

¹⁾ Sofern andere nationale Regelungen fehlen

Ankerschienen (HAC-C) mit Spezialschrauben (HBC)

Leistung

Charakteristische Widerstände der Ankerschienen (HAC-C) unter Querlast-Stahlversagen

Anhang C9

Tabelle 26: Charakteristische Widerstände unter Querlast in Schienenlängsrichtung – Stahlversagen der HAC-C-T (gezahnten warmgewalzten) Ankerschienen

Ankerschiene				HAC-C-T 29/20	HAC-C-T 40/22	HAC-C-T 40L	HAC-C-T 50/30	HAC-C-T 50L	HAC-C-T 53/34	
Stahlversagen: Verbindung zwischen Schienenlippen und Spezialschraube										
Charakteris- tischer Widerstand	HBC-T 29/20 M10	Stahl	$V_{Rk,s,l,x}$	[kN]	20,0	- 1)				
		Nichtrostender Stahl								
	HBC-T 29/20 M12	Stahl			24,0	- 1)				
		Nichtrostender Stahl								
	HBC-T 40/22 M10	Stahl			- 1)	28,0	- 1)			
		Nichtrostender Stahl								
	HBC-T 40/22 M12	Stahl			- 1)	28,0	- 1)			
		Nichtrostender Stahl								
HBC-T 40/22 M16	Stahl	- 1)	40,0	- 1)						
	Nichtrostender Stahl									
HBC-T 50/30 M16	Stahl	- 1)		50,0	50,0					
	Nichtrostender Stahl						71,4	51,0		
HBC-T 50/30 M20	Stahl	- 1)		55,0	55,0					
	Nichtrostender Stahl						71,4	51,0		
Montagefaktor	Stahl	γ_{inst}	[-]	1,2	1,2	1,4			1,4	
	Nichtrostender Stahl			1,0	1,2	1,4	1,0			

1) Produkt nicht vorhanden

Tabelle 27: Charakteristische Widerstände unter Querlast in Schienenlängsrichtung – Stahlversagen der (warmgewalzten) HAC-C(-P) Ankerschienen

Ankerschiene				HAC-C 40/22	HAC-C-P 40/22	HAC-C-P 40L	HAC-C 50/30	HAC-C-P 50/30	HAC-C-P 50L	HAC-C 52/34			
Stahlversagen: Verbindung zwischen Schienenlippen und Spezialschraube													
Charakteris- tischer Widerstand	HBC-40/22-N M16 8.8F	$V_{Rk,s,l,x}$	[kN]	- 2)	12,5	12,5	- 2)	- 1)					
	HBC-50/30-N M16 8.8F				- 2)						8,3	8,3	8,3
	HBC-50/30-N M20 8.8F										8,3	8,3	8,3
Montagefaktor		γ_{inst}	[-]	- 2)	1,4	- 2)	1,0						

1) Produkt nicht vorhanden

2) Leistung nicht bewertet

Ankerschienen (HAC-C) mit Spezialschrauben (HBC)

Leistung

Charakteristische Widerstände der Ankerschienen (HAC-C) unter Querlast-
Stahlversagen

Anhang C10

Tabelle 28: Charakteristische Widerstände unter Querlast – Betonversagen der HAC-C-T (gezahnten warmgewalzten) Ankerschienen

Ankerschiene				HAC-C-T 29/20	HAC-C-T 40/22	HAC-C-T 40L	HAC-C-T 50/30	HAC-C-T 50L	HAC-C-T 53/34
Betonversagen: Betonausbruch auf der lastabgewandten Seite									
Produktfaktor	k_8	[-]		2,0					
Teilsicherheitsbeiwert	$\gamma_{Mc}^{1)}$	[-]		1,5					
Betonversagen: Betonkantenbruch									
Produktfaktor k_{12}	gerissener	$k_{cr,V}$	[-]	7,5					
	ungerissener	$k_{ucr,V}$	[-]	10,5					
Teilsicherheitsbeiwert	$\gamma_{Mc}^{1)}$	[-]		1,5					

¹⁾ Sofern andere nationale Regelungen fehlen

Tabelle 29: Charakteristische Widerstände unter Querlast – Betonversagen der HAC-C(-P) (warmgewalzten) Ankerschienen

Ankerschiene				HAC-C 40/22	HAC-C-P 40/22	HAC-C-P 40L	HAC-C 50/30	HAC-C-P 50/30	HAC-C-P 50L	HAC-C 52/34
Betonversagen: Betonausbruch auf der lastabgewandten Seite										
Produktfaktor	k_8	[-]		2,0						
Teilsicherheitsbeiwert	$\gamma_{Mc}^{1)}$	[-]		1,5						
Betonversagen: Betonkantenbruch										
Produktfaktor k_{12}	gerissener	$k_{cr,V}$	[-]	7,5						
	ungerissener	$k_{ucr,V}$	[-]	10,5						
Teilsicherheitsbeiwert	$\gamma_{Mc}^{1)}$	[-]		1,5						

¹⁾ Sofern andere nationale Regelungen fehlen

Tabelle 30: Charakteristische Widerstände unter Querlast – Betonversagen der HAC-C (kaltverformten) Ankerschienen

Ankerschiene				HAC-C 28/15	HAC-C 38/17	HAC-C 40/25	HAC-C 49/30	HAC-C 54/33
Betonversagen: Betonausbruch auf der lastabgewandten Seite								
Produktfaktor	k_8	[-]	1,0	2,0				
Teilsicherheitsbeiwert	$\gamma_{Mc}^{1)}$	[-]		1,5				
Betonversagen: Betonkantenbruch								
Produktfaktor k_{12}	gerissener	$k_{cr,V}$	[-]	6,9	6,9	7,5		
	ungerissener	$k_{ucr,V}$	[-]	9,6	9,6	10,5		
Teilsicherheitsbeiwert	$\gamma_{Mc}^{1)}$	[-]		1,5				

¹⁾ Sofern andere nationale Regelungen fehlen

Ankerschienen (HAC-C) mit Spezialschrauben (HBC)

Leistung
Charakteristische Widerstände der Ankerschienen (HAC-C) unter Querlast-Betonversagen

Anhang C11

Tabelle 31: Verschiebungen unter Querlast der HAC-C(-T) (gezahnten warmgewalzten) Ankerschienen

Ankerschiene			HAC-C-T 29/20		HAC-C-T 40/22; HAC-C-T 40L			HAC-C-T 50/30; HAC-C-T 50L		HAC-C-T 53/34	
			M10	M12	M10	M12	M16	M16	M20	M16	M20
Schraubendurchmesser			M10	M12	M10	M12	M16	M16	M20	M16	M20
Stahl											
Senkrechte Querlast	V_y	[kN]	23,3		32,8			51,9		69,0	
Kurzzeit-Verschiebung ¹⁾	$\delta_{v0,y}$	[mm]	1,6		2,1			2,0		2,8	
Langzeit-Verschiebung ¹⁾	$\delta_{v\infty,y}$	[mm]	2,4		3,2			3,0		4,2	
Längsquerlast	V_x	[kN]	13,2	15,7	14,5	19,1	25,1	35,4	49,6	33,1	40,6
Kurzzeit-Verschiebung ¹⁾	$\delta_{v0,x}$	[mm]	1,1	0,7	0,9	1,0	1,2	1,4	1,5	1,4	1,5
Langzeit-Verschiebung ¹⁾	$\delta_{v\infty,x}$	[mm]	1,7	1,1	1,4	1,5	1,8	2,1	2,3	2,1	2,3
Nichtrostender Stahl											
Senkrechte Querlast	V_y	[kN]	25,0		34,7			61,8		66,8	
Kurzzeit-Verschiebung ¹⁾	$\delta_{v0,y}$	[mm]	1,7		2,5			2,5		2,5	
Langzeit-Verschiebung ¹⁾	$\delta_{v\infty,y}$	[mm]	2,6		3,8			3,8		3,8	
Längsquerlast	V_x	[kN]	14,5	17,1	16,9	20,4	26,5	42,1	53,8	38,4	
Kurzzeit-Verschiebung ¹⁾	$\delta_{v0,x}$	[mm]	1,1	2,4	0,7	2,1	0,9	1,4	1,6	1,3	
Langzeit-Verschiebung ¹⁾	$\delta_{v\infty,x}$	[mm]	1,6	3,6	1,1	3,2	1,4	2,1	2,4	2,0	

¹⁾ Verschiebung in der Mitte zwischen zwei Ankern der Ankerschiene, einschließlich Schlupf der Schraube, Schienenlippenverformung und Schlupf der Ankerschiene im Beton

Tabelle 32: Verschiebungen unter Querlast der HAC-C(-P) (warmgewalzten) Ankerschienen

Ankerschiene			HAC-C 40/22	HAC-C-P 40/22	HAC-C-P 40L	HAC-C 50/30	HAC-C-P 50/30	HAC-C-P 50L	HAC-C 52/34
			Senkrechte Querlast	V_y	[kN]	10,3	29,0	29,0	16,0
Kurzzeit-Verschiebung ¹⁾	$\delta_{v0,y}$	[mm]	2,1	2,0	2,0	2,6	2,7	3,7	3,7
Langzeit-Verschiebung ¹⁾	$\delta_{v\infty,y}$	[mm]	3,1	3,5	3,5	3,9	4,0	5,5	5,5
Längsquerlast	V_x	[kN]	²⁾	5,2	5,2	²⁾	3,3	3,3	7,9
Kurzzeit-Verschiebung ¹⁾	$\delta_{v0,x}$	[mm]	²⁾	0,1	0,1	²⁾	0,1	0,1	1,4
Langzeit-Verschiebung ¹⁾	$\delta_{v\infty,x}$	[mm]	²⁾	0,2	0,2	²⁾	0,2	0,2	2,0

¹⁾ Verschiebung in der Mitte zwischen zwei Ankern der Ankerschiene, einschließlich Schlupf der Schraube, Schienenlippenverformung und Schlupf der Ankerschiene im Beton;

²⁾ Leistung nicht bewertet

Ankerschienen (HAC-C) mit Spezialschrauben (HBC)

Leistung
Verschiebungen unter Querlast

Anhang C12

Tabelle 33: Verschiebungen unter Querlast senkrecht zur Schienenlängsachse der HAC-C (kaltverformten) Ankerschienen

Ankerschiene			HAC-C 28/15	HAC-C 38/17	HAC-C 40/25	HAC-C 49/30	HAC-C 54/33
Senkrechte Querlast	V_y	[kN]	3,6	7,1	7,9	12,3	21,8
Kurzzeit-verschiebung ¹⁾	$\delta_{V0,y}$	[mm]	0,6	1,3	1,4	1,4	1,6
Langzeit-verschiebung ¹⁾	$\delta_{V\infty,y}$	[mm]	0,9	2,0	2,1	2,1	2,4

¹⁾ Verschiebung in der Mitte zwischen zwei Anker der Ankerschiene, einschließlich Schlupf der Schraube, Schienenlippenverformung und Schlupf der Ankerschiene im Beton

Tabelle 34: Charakteristische Widerstände unter kombinierter Zug- und Querlast der HAC-C-T (gezahnten warmgewalzten) Ankerschienen

Ankerschiene			HAC-C-T 29/20	HAC-C-T 40/22	HAC-C-T 40L	HAC-C-T 50/30	HAC-C-T 50L	HAC-C-T 53/34
Stahlversagen der Schienenlippe und Biegung der Ankerschiene								
Produktfaktor	k_{13}	[-]	Werte gemäß EN 1992-4, Abschnitt 7.4.3.1					
Stahlversagen des Ankers und der Verbindung zwischen Anker und Schiene								
Produktfaktor	k_{14}	[-]	Werte gemäß EN 1992-4, Abschnitt 7.4.3.1					

Tabelle 35: Charakteristische Widerstände unter kombinierter Zug- und Querlast der HAC-C-P (warmgewalzten) Ankerschienen

Ankerschiene			HAC-C 40/22	HAC-C-P 40/22	HAC-C-P 40L	HAC-C 50/30	HAC-C-P 50/30	HAC-C-P 50L	HAC-C 52/34
Stahlversagen der Schienenlippe und Biegung der Ankerschiene									
Produktfaktor	k_{13}	[-]	Werte gemäß EN 1992-4, Abschnitt 7.4.3.1						
Stahlversagen des Ankers und der Verbindung zwischen Anker und Schiene									
Produktfaktor	k_{14}	[-]	Werte gemäß EN 1992-4, Abschnitt 7.4.3.1						

Tabelle 36: Charakteristische Widerstände Ankerschienen unter kombinierter Zug- und Querlast der HAC-C (kaltverformten)

Ankerschiene			HAC-C 28/15	HAC-C 38/17	HAC-C 40/25	HAC-C 49/30	HAC-C 54/33
Stahlversagen der Schienenlippe und Biegung der Ankerschiene							
Produktfaktor	k_{13}	[-]	Werte gemäß EN 1992-4, Abschnitt 7.4.3.1				
Stahlversagen des Ankers und der Verbindung zwischen Anker und Schiene							
Produktfaktor	k_{14}	[-]	Werte gemäß EN 1992-4, Abschnitt 7.4.3.1				

Ankerschienen (HAC-C) mit Spezialschrauben (HBC)

Leistung
Verschiebungen unter Querlast.
Charakteristische Widerstände unter kombinierter Zug- und Querlast

Anhang C13

Tabelle 37: Charakteristische Widerstände unter Zuglast – Stahlversagen der Spezialschrauben (HBC)

Spezialschraube		M8	M10	M12	M16	M20			
Stahlversagen									
Charakteristischer Widerstand (Zuglast)	$N_{Rk,s}^{1)}$	[kN]	Schrauben für HAC-C-T (warmgewalzten) Ankerschienen						
			HBC-T 29/20	8.8	- ³⁾	46,4	67,4	- ³⁾	
				A4-70 ¹⁾	- ³⁾	40,6	59,0	- ³⁾	
			HBC-T 40/22	8.8	- ³⁾	46,4	67,4	125,6	- ³⁾
				A4-70 ¹⁾	- ³⁾	40,6	59,0	109,9	- ³⁾
			HBC-T 50/30	8.8	- ³⁾			125,6	203,4
				A4-70 ¹⁾	- ³⁾			109,9	171,5
			Schrauben für HAC-C (warmgewalzten und/oder kaltverformten) Ankerschienen						
			HBC-40/22	8.8	- ³⁾	- ³⁾	67,4	125,6	- ³⁾
				A4-70 ¹⁾	- ³⁾	20,5	59,0	91,0	- ³⁾
			HBC-40/22-N	8.8	- ³⁾			125,6	- ³⁾
				A4-70 ¹⁾	- ³⁾				
			HBC-50/30	8.8	- ³⁾		67,4	125,6	147,1
				A4-70 ¹⁾	- ³⁾		59,0	109,9	121,2
			HBC-50/30-N	8.8	- ³⁾			125,6	186,6
				A4-70 ¹⁾	- ³⁾				
			Schrauben für HAC-C kaltverformten Ankerschienen						
			HBC-28/15	8.8	22,4	35,4	44,3	- ³⁾	
				A4-70 ¹⁾	25,6	38,9	51,3	- ³⁾	
			HBC-38/17	8.8	- ³⁾	35,4	35,4	55,8	- ³⁾
A4-70 ¹⁾	- ³⁾	20,5		47,2	53,0	- ³⁾			
Teilsicherheits- beiwert	$\gamma_{Ms}^{2)}$	[-]	HBC-T 29/20 HBC-T 40/22 HBC-T 50/30	8.8	1,50 and 1,51 ⁴⁾				
			HBC-40/22(-N) HBC-50/30(-N) HBC-28/15 HBC-38/17	A4-70 ¹⁾	1,87				

1) Werkstoffe gemäß Tabelle 5, Anhang A8

2) Sofern andere nationale Regelungen fehlen

3) Produkt nicht vorhanden

4) Teilsicherheitsbeiwert $\gamma_{Ms} = 1,51$ nur für HBC-T 53/34 M20 und 1,5 für die übrigen Schrauben

Ankerschienen (HAC-C) mit Spezialschrauben (HBC)

Leistung

Charakteristische Widerstände der Spezialschrauben unter Zuglast

Anhang C14

**Tabelle 38: Charakteristische Widerstände unter Querlast – Stahlversagen der
Spezierschrauben (HBC)**

Spezierschraube		M8	M10	M12	M16	M20			
Stahlversagen									
Charakteristischer Widerstand (Querlast)	$V_{Rk,s}^{1)}$	[kN]	Schrauben für HAC-C-T (warmgewalzten) Ankerschienen						
			HBC-T 29/20	8.8	- ³⁾	23,2	33,7	- ³⁾	
				A4-70 ¹⁾	- ³⁾	24,4	35,4	- ³⁾	
			HBC-T 40/22	8.8	- ³⁾	23,2	33,7	62,8	- ³⁾
				A4-70 ¹⁾	- ³⁾	24,4	35,4	65,9	- ³⁾
			HBC-T 50/30	8.8	- ³⁾			62,8	101,7
				A4-70 ¹⁾	- ³⁾			65,9	102,9
			Schrauben für HAC-C (gewalzten und/oder kaltverformten) Ankerschienen						
			HBC-40/22	8.8	- ³⁾	23,2	33,7	62,8	- ³⁾
				A4-70 ¹⁾	- ³⁾	24,4	35,4	65,9	- ³⁾
			HBC-40/22-N	8.8	- ³⁾			62,8	- ³⁾
				A4-70 ¹⁾	- ³⁾				
			HBC-50/30	8.8	- ³⁾		33,7	62,8	101,7
				A4-70 ¹⁾	- ³⁾		35,4	65,9	102,9
			HBC-50/30-N	8.8	- ³⁾			62,8	101,7
				A4-70	- ³⁾				
			Schrauben für HAC-C kaltverformten Ankerschienen						
			HBC-28/15	8.8	14,6	23,2	33,7	- ³⁾	
				A4-70	15,4	24,4	35,4	- ³⁾	
			HBC-38/17	8.8	- ³⁾	23,2	33,7	62,8	- ³⁾
				A4-70 ¹⁾	- ³⁾	24,4	35,4	65,9	- ³⁾
Teilsicherheits- beiwert	$\gamma_{Ms}^{2)}$	[-]	HBC-T 29/20 HBC-T 40/22 HBC-T 50/30	8.8	1,25 and 1,26 ⁴⁾				
			HBC-40/22(-N) HBC-50/30(-N) HBC-28/15 HBC-38/17	A4-70	1,56				

1) Werkstoffe gemäß Tabelle 5, Anhang A8

2) Sofern andere nationale Regelungen fehlen

3) Produkt nicht vorhanden

4) Teilsicherheitsbeiwert $\gamma_{Ms} = 1,26$ nur für HBC-T 53/34 M20 und 1,25 für übrige Schrauben

Ankerschienen (HAC-C) mit Spezierschrauben (HBC)

Leistung

Charakteristische Widerstände der Spezierschrauben unter Querlast

Anhang C15

Tabelle 39: Charakteristische Widerstände unter Querlast mit Hebelarm – Stahlversagen der Spezialschrauben (HBC)

Spezialschraube		M8	M10	M12	M16	M20			
Stahlversagen									
Charakteristischer Biege­widerstand	$M^{0}_{RK,s^{5)}$	[Nm]	HBC-T 29/20	8.8	- ³⁾	59,8	104,8	- ³⁾	
				A4-70 ²⁾	- ³⁾	52,3	91,7	- ³⁾	
			HBC-T 40/22	8.8	- ³⁾	59,8	104,8	266,4	- ³⁾
				A4-70 ²⁾	- ³⁾	52,3	91,7	233,1	- ³⁾
			HBC-T 50/30	8.8	- ³⁾			266,4	538,7
				A4-70 ²⁾	- ³⁾			233,1	454,4
			HBC-50/30(-N) HBC-40/22(-N) HBC-38/17 HBC-28/15	8.8	30,0	59,8	104,8	266,4	538,7
				A4-70 ²⁾	26,2	52,3	91,7	233,1	454,4
Teilsicherheitsbeiwert	$\gamma_{Ms}^{1)}$	[-]	HBC-T 29/20 HBC-T 40/22 HBC-T 50/30 HBC-40/22(-N) HBC-50/30(-N) HBC-28/15 HBC-38/17	8.8	1,25 und 1,26 ⁴⁾				
				A4-70 ²⁾	1,56				
Innerer Hebelarm	a	[mm]	HBC-T 29/20	29/20	- ³⁾	19,0	20,0	- ³⁾	
			HBC-T 40/22	40/22	- ³⁾	23,0	24,0	26,0	- ³⁾
			HBC-T 50/30	50/30 53/34	- ³⁾			32,0	34,0
			HBC-40/22(-N)	40/22	- ³⁾	24,3	25,7	27,3	- ³⁾
			HBC-50/30(-N)	50/30	- ³⁾		29,9	31,7	33,9
			HBC-28/15	28/15	17,3	18,7	20,0	- ³⁾	
			HBC-38/17	38/17	- ³⁾	23,0	24,3	26,3	- ³⁾

1) Sofern andere nationale Regelungen fehlen

2) Werkstoffe gemäß Tabelle 5, Anhang A8;

3) Produkt nicht vorhanden;

4) Teilsicherheitsbeiwert 1,26 für HBC-T 50/30 M20 und 1,25 für übrige Schrauben

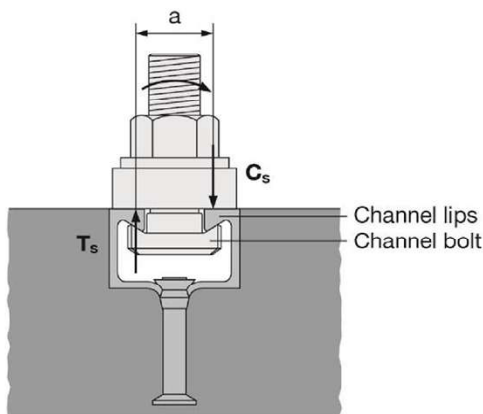

5) Der charakteristische Biege­widerstand gemäß Tabelle 39 ist wie folgt begrenzt:

$$M^{0}_{RK,s} \leq 0,5 \cdot N_{RK,s,l} \cdot a \quad (N_{RK,s,l} \text{ gemäß Tabelle 11, 12 und 13})$$

und

$$M^{0}_{RK,s} \leq 0,5 \cdot N_{RK,s} \cdot a \quad (N_{RK,s} \text{ gemäß Tabelle 29})$$

a = innerer Hebelarm gemäß Tabelle 30

T_s = Zugkraft auf die Schienenlippe

C_s = Druckkraft auf die Schienenlippe

Ankerschienen (HAC-C) mit Spezialschrauben (HBC)

Leistung

Charakteristische Widerstände der Spezialschrauben unter Querlast mit Hebelarm

Anhang C16

Tabelle 40: Kombination der Ankerschienen und Spezialschrauben für Ermüdungsbeanspruchung unter Zuglast (Bemessungsmethode I oder II für Bewertungsverfahren A1, A2 und B gemäß EOTA TR050)

Ankerschiene			Spezialschraube			
Ankerschiene	Ankertyp ¹⁾	Beschichtung	Spezial- schraube	Durch- messer	Festigkeits- klasse	Beschichtung
HAC-C-T 29/20	R	F	HBC-T 29/20	M10	8.8	G F
				M12		
HAC-C-T 40/22 HAC-C-T 40L			HBC-T 40/22	M12		
				M16		
HAC-C-T 50/30 HAC-C-T 50L HAC-C-T 53/34			HBC-T 50/30	M16		
				M20		
HAC-C-P 40/22 HAC-C-P 40L			HBC-40/22	M12		
				M16		
HAC-C-P 50/30 HAC-C-P 50L			HBC-50/30	M16		
				M20		
HAC-C 52/34			HBC-50/30	M16		
				M20		

¹⁾ R – Rundanker gemäß Anhang A3 und A6

Ankerschienen (HAC-C) mit Spezialschrauben (HBC)

Leistung

Charakteristische Widerstände für Ermüdungsbeanspruchung unter Zuglast gemäß Bewertungsverfahren A1, A2 und B

Anhang C17

**Tabelle 41: Charakteristische Widerstände für Ermüdungsbeanspruchung unter Zuglast
Stahlversagen nach n Lastzyklen ohne statischen Lastanteil ($N_{Ed} = 0$) (Bemessungsmethode I gemäß
EOTA TR050) für HAC-C-T (warmgewalzte gezahnte) Ankerschienen**

Ankerschiene			HAC-C-T 29/20	HAC-C-T 40/22	HAC-C-T 40L	HAC-C-T 50/30	HAC-C-T 50L	HAC-C-T 53/34
Stahlversagen								
Charakteristische Widerstände unter Ermüdungsbeanspruchung (Zug) ohne statische Vorlast ($N_{Ed} = 0$)	$\Delta N_{Rk,s,0,n}$	[kN]	$\leq 10^4$	15,4	20,4	20,3	33,5	
			$\leq 10^5$	8,4	10,8	8,5	18,2	
			$\leq 10^6$	4,4	4,9	4,5	9,0	
			$\leq 2 \cdot 10^6$	3,9	4,1	4,2	7,5	
			$\leq 5 \cdot 10^6$	3,4	3,4	4,0	6,1	
			$\leq 10^8$	3,0	2,8	3,9	4,6	
			$> 10^8$	3,0	2,8	3,9	4,5	

**Tabelle 42: Charakteristische Widerstände für Ermüdungsbeanspruchung unter Zuglast
Stahlversagen nach n Lastzyklen ohne statischen Lastanteil ($N_{Ed} = 0$) (Bemessungsmethode I gemäß
EOTA TR050) für HAC-C(-P) (warmgewalzte) Ankerschienen**

Ankerschiene			HAC-C-P 40/22	HAC-C-P 40L	HAC-C-P 50/30	HAC-C-P 50L	HAC-C 52/34
Stahlversagen							
Charakteristische Widerstände unter Ermüdungsbeanspruchung (Zug) ohne statische Vorlast ($N_{Ed} = 0$)	$\Delta N_{Rk,s,0,n}$	[kN]	$\leq 10^4$	16,4	20,9	24,3	
			$\leq 10^5$	7,7	9,0	12,5	
			$\leq 10^6$	3,2	4,2	7,1	
			$\leq 2 \cdot 10^6$	2,6	3,7	6,4	
			$\leq 5 \cdot 10^6$	2,2	3,4	5,9	
			$\leq 10^8$	2,0	3,3	5,7	
			$> 10^8$	1,8	3,2	5,5	

Ankerschienen (HAC-C) mit Spezialschrauben (HBC)

Leistung

Charakteristische Widerstände für Ermüdungsbeanspruchung unter Zuglast gemäß
Bewertungsverfahren A1, A2 und B

Anhang C18

Tabelle 43: Abminderungsfaktor $\eta_{c,fat}$ für Ermüdungsbeanspruchung unter Zuglast – Betonversagen nach n Lastzyklen ohne statischen Lastanteil ($N_{Ed} = 0$) für HAC-C-T (warmgewalzte gezahnte) Ankerschienen (Bemessungsmethode I oder II für Bewertungsverfahren A1, A2 und B gemäß EOTA TR050)

Ankerschiene				HAC-C-T 29/20	HAC-C-T 40/22	HAC-C-T 40L	HAC-C-T 50/30	HAC-C-T 50L	HAC-C-T 53/34
Herausziehen und Betonausbruch									
Abminderungsfaktor nach n Lastzyklen ohne statische Vorlast ($N_{Ed} = 0$) für: $\Delta N_{Rk,p;0;n} = \eta_{c,fat} \cdot N_{Rk,p}$ $\Delta N_{Rk,c;0;n} = \eta_{c,fat} \cdot N_{Rk,c}$ mit $N_{Rk,p}$ gemäß Anhang C3 und C4 und $N_{Rk,c}$ berechnet gemäß EN 1992-4 and EOTA TR 047	$\eta_{c,fat}$	[-]	$\leq 10^4$	0,736					
			$\leq 10^5$	0,665					
			$\leq 10^6$	0,600					
			$\leq 2 \cdot 10^6$	0,582					
			$\leq 5 \cdot 10^6$	0,559					
			$\leq 6 \cdot 10^7$	0,500					
			$> 6 \cdot 10^7$ ¹⁾	0,500					

¹⁾ für $\Delta N_{Rk,p;0;\infty}$, $\Delta N_{Rk,c;0;\infty}$

Tabelle 44: Abminderungsfaktor $\eta_{c,fat}$ für Ermüdungsbeanspruchung unter Zuglast – Betonversagen nach n Lastzyklen ohne statischen Lastanteil ($N_{Ed} = 0$) für HAC-C (warmgewalzte) Ankerschienen (Bemessungsmethode I oder II für Bewertungsverfahren A1, A2 und B gemäß EOTA TR050)

Ankerschiene				HAC-C-P 40/22	HAC-C-P 40L	HAC-C-P 50/30	HAC-C-P 50L	HAC-C 52/34
Herausziehen und Betonausbruch								
Abminderungsfaktor nach n Lastzyklen ohne statische Vorlast ($N_{Ed} = 0$) für: $\Delta N_{Rk,p;0;n} = \eta_{c,fat} \cdot N_{Rk,p}$ $\Delta N_{Rk,c;0;n} = \eta_{c,fat} \cdot N_{Rk,c}$ mit $N_{Rk,p}$ gemäß Anhang C3 und C4 und $N_{Rk,c}$ berechnet gemäß EN 1992-4 und EOTA TR 047	$\eta_{c,fat}$	[-]	$\leq 10^4$	0,736				
			$\leq 10^5$	0,665				
			$\leq 10^6$	0,600				
			$\leq 2 \cdot 10^6$	0,582				
			$\leq 5 \cdot 10^6$	0,559				
			$\leq 6 \cdot 10^7$	0,500				
			$> 6 \cdot 10^7$ ¹⁾	0,500				

¹⁾ für $\Delta N_{Rk,p;0;\infty}$, $\Delta N_{Rk,c;0;\infty}$

Ankerschienen (HAC-C) mit Spezialschrauben (HBC)

Leistung

Charakteristische Widerstände für Ermüdungsbeanspruchung unter Zuglast gemäß Bewertungsverfahren A1, A2 und B

Anhang C19

Tabelle 45: Charakteristische Widerstände für Ermüdungsbeanspruchung unter Zuglast – Stahlversagen mit $n \rightarrow \infty$ Lastzyklen ohne statischen Lastanteil ($N_{Ed} = 0$) (Bemessungsmethode II für Bewertungsverfahren B gemäß EOTA TR050) für HAC-C-T (warmgewalzte gezahnte) Ankerschienen

Ankerschiene	HAC-C-T 29/20	HAC-C-T 40/22	HAC-C-T 40L	HAC-C-T 50/30	HAC-C-T 50L	HAC-C-T 53/34
Stahlversagen						
Charakteristischer Ermüdungsgrenzwiderstand ($n \rightarrow \infty$) für alle Stahlversagensarten ohne statischen Lastanteil ($N_{Ed} = 0$)	$\Delta N_{Rk,s;0;\infty}$ [kN]	$n \rightarrow \infty$	3,0	2,8	3,9	4,5
Herausziehen und Betonausbruch						
Abminderungsfaktor für Ermüdungsgrenzwiderstand ($n \rightarrow \infty$) für Betonversagen ohne statischen Lastanteil ($N_{Ed} = 0$)	$\eta_{c,fat}$	[-]	$n \rightarrow \infty$	0,5		

Tabelle 46: Charakteristische Widerstände für Ermüdungsbeanspruchung unter Zuglast – Stahlversagen mit $n \rightarrow \infty$ Lastzyklen ohne statischen Lastanteil ($N_{Ed} = 0$) (Bemessungsmethode II für Bewertungsverfahren B gemäß EOTA TR050) für HAC-C-T (warmgewalzte) Ankerschienen

Ankerschiene	HAC-C-P 40/22	HAC-C-P 40L	HAC-C-P 50/30	HAC-C-P 50L	HAC-C 52/34
Stahlversagen					
Charakteristischer Ermüdungsgrenzwiderstand ($n \rightarrow \infty$) für alle Stahlversagensarten ohne statischen Lastanteil ($N_{Ed} = 0$)	$\Delta N_{Rk,s;0;\infty}$ [kN]	$n \rightarrow \infty$	1,8	3,2	5,5
Herausziehen und Betonausbruch					
Abminderungsfaktor für Ermüdungsgrenzwiderstand ($n \rightarrow \infty$) für Betonversagen ohne statischen Lastanteil ($N_{Ed} = 0$)	$\eta_{c,fat}$	[-]	$n \rightarrow \infty$	0,5	

Für die Reduzierung der in den Tabellen 41, 42, 45 und 46 angegebenen charakteristischen Widerstände im Übergangsbereich vom statischen Widerstand zum Ermüdungsgrenzwiderstand werden die Teilsicherheitsbeiwerte wie folgt berechnet:

Sofern andere nationale Regelungen fehlen, werden die folgenden Teilsicherheitsbeiwerte γ_M und $\gamma_{M,fat}$ für die Bemessungsmethode I gemäß EOTA TR 050 empfohlen:

γ_M gemäß Anhang C1

$\gamma_{M,fat} = 1,35$

Sofern andere nationale Regelungen fehlen, wird der folgende Teilsicherheitsbeiwert $\gamma_{M,fat}$ für die Bemessungsmethode II (Tabelle 34) gemäß EOTA TR 050 empfohlen:

$\gamma_{M,fat} = 1,35$

Ankerschienen (HAC-C) mit Spezialschrauben (HBC)

Leistung

Charakteristische Widerstände für Ermüdungsbeanspruchung unter Zuglast gemäß Bewertungsverfahren A1, A2 und B

Anhang C20

Tabelle 47: Kombinationen der Ankerschienen und Spezialschrauben für seismische Beanspruchung (Seismische Leistungskategorie C1)

Ankerschiene	Spezialschraube			
	Schienenprofil	Spezialschraube	Durchmesser	Festigkeitsklasse
HAC-C-T 29/20	HBC-T 29/20	M10	8.8 A4	F ¹⁾ R ²⁾
		M12		
HAC-C-T 40/22 HAC-C-T 40L	HBC-T 40/22	M12		
		M16		
HAC-C-T 50/30 HAC-C-T 50L HAC-C-T 53/34	HBC-T 50/30	M16		
		M20		

¹⁾ Feuerverzinkt;

²⁾ Nichtrostender Stahl

Tabelle 48: Charakteristische Widerstände für seismische Beanspruchung unter Zuglast – Stahlversagen der HAC-C-T (warmgewalzte gezahnte) Ankerschienen

Ankerschiene				HAC-C-T 29/20	HAC-C-T 40/22	HAC-C-T 40L	HAC-C-T 50/30	HAC-C-T 50L	HAC-C-T 53/34
Stahlversagen: Anker									
Charakteristischer Widerstand	Stahl	$N_{Rk,s,a,eq}$	[kN]	35,0	41,0	57,0	73,5		
	Nichtrostender Stahl				45,0				
Teilsicherheitsbeiwert		$\gamma_{Ms,eq}^{1)}$	[-]	1,8					
Stahlversagen: Verbindung zwischen Anker und Schiene									
Charakteristischer Widerstand	Stahl	$N_{Rk,s,c,eq}$	[kN]	33,0	40,0	55,0	73,5		
	Nichtrostender Stahl			35,0	42,0	60,0			
Teilsicherheitsbeiwert		$\gamma_{Ms,ca,eq}^{1)}$	[-]	1,8					
Stahlversagen: Aufbiegen der Schienenlippe									
Charakteristischer Achsabstand der Spezialschrauben für $N_{Rk,s,l}$		$s_{l,N,eq}$	[mm]	61	76	100	107		
Charakteristischer Widerstand	Stahl	$N^0_{Rk,s,l,eq}$	[kN]	35,0	45,0	64,0	85,0		
	Nichtrostender Stahl				42,0				
Teilsicherheitsbeiwert		$\gamma_{Ms,l,eq}^{1)}$	[-]	1,8					

¹⁾ Sofern andere nationale Regelungen fehlen

Ankerschienen (HAC-C) mit Spezialschrauben (HBC)

Leistung

Charakteristische Widerstände der Ankerschienen und Spezialschrauben für seismische Beanspruchung (Seismische Leistungskategorie C1)

Anhang C21

Tabelle 49: Charakteristischer Biege­widerstand der HAC-C-T (warmgewalzte gezahnte) Ankerschienen für seismische Beanspruchung unter Zuglast

Ankerschiene				HAC-C-T 29/20	HAC-C-T 40/22	HAC-C-T 40 L	HAC-C-T 50/30	HAC-C-T 50L	HAC-C-T 53/34
Stahlversagen: Biegung der Ankerschiene									
Charakteristischer Biege­widerstand der Schiene	Stahl	$M_{RK,s,flex,eq}$	[Nm]	977	1557		3256		4870
	Nichtrostender Stahl			1100	1754		3366		4626
Teilsicherheitsbeiwert		$\gamma_{Ms,flex,eq}^1$	[-]	1,15					

¹⁾ Sofern andere nationale Regelungen fehlen

Tabelle 50: Charakteristische Widerstände für seismische Beanspruchung unter Querlast – Stahlversagen der HAC-C-T (warmgewalzte gezahnte) Ankerschienen

Ankerschiene				HAC-C-T 29/20	HAC-C-T 40/22	HAC-C-T 40L	HAC-C-T 50/30	HAC-C-T 50L	HAC-C-T 53/34
Stahlversagen: Anker									
Charakteristischer Widerstand	Stahl	$V_{RK,s,a,y,eq}$	[kN]	37,0	52,0		80,0		120,0
	Nichtrostender Stahl				49,5		100,0		
Charakteristischer Widerstand	Stahl	$V_{RK,s,a,x,eq}$	[kN]	22,9	24,7		35,2		44,1
	Nichtrostender Stahl				28,3		37,1		
Teilsicherheitsbeiwert	Stahl	$\gamma_{Ms,eq}^1$	[-]	1,5					
	Nichtrostender Stahl								
Stahlversagen: Verbindung zwischen Anker und Schiene									
Charakteristischer Widerstand	Stahl	$V_{RK,s,c,y,eq}$	[kN]	37,0	52,0		80,0		120,0
	Nichtrostender Stahl				49,5		100,0		
Charakteristischer Widerstand	Stahl	$V_{RK,s,c,x,eq}$	[kN]	19,8	24,0		31,4		44,1
	Nichtrostender Stahl				21,0		25,2		
Teilsicherheitsbeiwert		$\gamma_{Ms,eq}^1$	[-]	1,8					
Stahlversagen: Aufbiegen der Schienenlippe unter Querlast senkrecht zur Schienen­längsrichtung									
Charakteristischer Achs­abstand der Spezialschrauben für $V_{RK,s,l}$		$s_{l,V,eq}$	[mm]	61,0	76,0		100,0		107,0
Charakteristischer Widerstand	Stahl	$V^0_{RK,s,l,y,eq}$	[kN]	37,0	52,0		80,0		120,0
	Nichtrostender Stahl				49,5		100,0		
Teilsicherheitsbeiwert		$\gamma_{Ms,l,eq}^1$	[-]	1,8					

¹⁾ Sofern andere nationale Regelungen fehlen

Ankerschienen (HAC-C) mit Spezialschrauben (HBC)

Leistung

Charakteristische Widerstände der Ankerschienen für seismische Beanspruchung (Seismische Leistungskategorie C1)

Anhang C22

Tabelle 51: Charakteristische Widerstände für seismische Beanspruchung unter Querlast in Schienenlängsrichtung – Stahlversagen der HAC-C-T (warmgewalzte gezahnte) Ankerschienen

Ankerschiene				HAC-C-T 29/20	HAC-C-T 40/22	HAC-C-T 40L	HAC-C-T 50/30	HAC-C-T 50L	HAC-C-T 53/34	
Stahlversagen: Verbindung zwischen Schienenlippen und Spezialschraube										
Charakteris- tischer Widerstand	HBC-T 29/20 M10	Stahl	$V_{Rk,s,l,x,eq}$	[kN]	20,0	- 1)				
		Nichtrostender Stahl								
	HBC-T 29/20 M12	Stahl			24,0	- 1)				
		Nichtrostender Stahl								
	HBC-T 40/22 M10	Stahl			- 1)	- 1)	- 1)			
		Nichtrostender Stahl								
	HBC-T 40/22 M12	Stahl			- 1)	28,0	- 1)			
		Nichtrostender Stahl								
HBC-T 40/22 M16	Stahl	- 1)	40,0	- 1)						
	Nichtrostender Stahl									
HBC-T 50/30 M16	Stahl	- 1)		50,0	50,0					
	Nichtrostender Stahl						71,4	51,0		
HBC-T 50/30 M20	Stahl	- 1)		52,3	55,0					
	Nichtrostender Stahl						71,4	51,0		
Montagefaktor	Stahl	$\gamma_{inst,eq}$	[-]	1,2	1,2	1,4				1,4
	Nichtrostender Stahl			1,0	1,2	1,4	1,0			

1) Leistung nicht bewertet

Ankerschienen (HAC-C) mit Spezialschrauben (HBC)

Leistung

Charakteristische Widerstände der Ankerschienen und Spezialschrauben für seismische Beanspruchung (Seismische Leistungskategorie C1)

Anhang C23

Tabelle 52: Charakteristische Widerstände für seismische Beanspruchung unter Zug- und Querlast – Stahlversagen der Spezialschrauben (HBC)

Spezialschraube				M10	M12	M16	M20	
Stahlversagen								
Charakteristischer Widerstand (Zuglast)	$N_{Rk,s,eq}^{1)}$	[kN]	HBC-T 29/20	8.8	46,4	67,4	- ³⁾	
				A4-70 ¹⁾	40,6	59,0	- ³⁾	
			HBC-T 40/22	8.8	- ⁴⁾	67,4	125,6	- ³⁾
				A4-70 ¹⁾	- ⁴⁾	59,0	109,9	- ³⁾
			HBC-T 50/30	8.8	- ³⁾		125,6	203,4
				A4-70 ¹⁾	- ³⁾		109,9	171,5
Teilsicherheitsbeiwert	$\gamma_{Ms,eq}^{2)}$	[-]	HBC-T 50/30 HBC-T 40/22 HBC-T 29/20	8.8	1,50 und 1,51 ⁵⁾			
				A4-70 ¹⁾	1,87			
Charakteristischer Widerstand (Querlast)	$V_{Rk,s,eq}^{1)}$	[kN]	HBC-T 29/20	8.8	23,2	33,7	- ³⁾	
				A4-70 ¹⁾	24,4	35,4	- ³⁾	
			HBC-T 40/22	8.8	- ⁵⁾	33,7	62,8	- ³⁾
				A4-70 ¹⁾	- ⁵⁾	35,4	65,9	- ³⁾
			HBC-T 50/30	8.8	- ³⁾		62,8	101,7
				A4-70 ¹⁾	- ³⁾		65,9	102,9
Teilsicherheitsbeiwert	$\gamma_{Ms,eq}^{2)}$	[-]	HBC-T 50/30 HBC-T 40/22 HBC-T 29/20	8.8	1,25 und 1,26 ⁵⁾			
				A4-70	1,56			

¹⁾ gemäß Tabelle 5, Anhang A8

²⁾ Sofern andere nationale Regelungen fehlen

³⁾ Produkt nicht vorhanden

⁴⁾ Leistung nicht bewertet

⁵⁾ Teilsicherheitsbeiwert 1,51 und 1,26 für HBC-T 50/30 M20; 1,5 und 1,25 für übrige Schrauben

Ankerschienen (HAC-C) mit Spezialschrauben (HBC)

Leistung

Charakteristische Widerstände der Spezialschrauben für seismische Beanspruchung (Seismische Leistungskategorie C1)

Anhang C24

Tabelle 53: Charakteristische Widerstände der Ankerschienen unter Brandbeanspruchung – Stahlversagen für HAC-C-T (warmgewalzte gezahnte) Ankerschienen

Spezialschrauben				M10	M12	M16	M20				
Stahlversagen: Anker, Verbindung zwischen Anker und Schiene und Aufbiegen der Schienenlippe											
Stahl, Nichtrostender Stahl A2											
Charakterischer Widerstand unter Brandbeanspruchung	HAC-C-T 29/20	R30	$N_{Rk,s,fi}$ = $V_{Rk,s,y,fi}$	[kN]	1,2	1,2	- 2)	- 2)			
		R60			0,9	0,9					
		R90			0,6	0,6					
		R120			0,5	0,5					
	HAC-C-T 40/22	R30			1,2	1,2	6,2	- 2)			
		R60			0,9	0,9	4,6				
		R90			0,6	0,6	2,9				
		R120			0,5	0,5	2,1				
	HAC-C-T 50/30	R30			- 2)	- 2)	6,4	10,7			
		R60			- 2)	- 2)	4,8	8,0			
		R90			- 2)	- 2)	3,2	5,2			
		R120			- 2)	- 2)	2,3	3,8			
	HAC-C-T 53/34	R30			- 2)	- 2)	6,5	9,0			
		R60			- 2)	- 2)	5,0	6,7			
		R90			- 2)	- 2)	3,4	4,5			
		R120			- 2)	- 2)	2,7	3,4			
	Nichtrostender Stahl A4										
	Charakterischer Widerstand unter Brandbeanspruchung	HAC-C-T A4 29/20			R30	$N_{Rk,s,fi}$ = $V_{Rk,s,y,fi}$	[kN]	9,9	11,1	- 2)	- 2)
					R60			6,1	7,2		
					R90			2,2	3,4		
R120			0,3	1,4							
HAC-C-T A4 40/22		R30	9,9	11,1	20,0			- 2)			
		R60	6,1	7,2	17,7						
		R90	2,2	3,4	8,2						
		R120	0,3	1,4	3,5						
HAC-C-T A4 50/30		R30	- 2)	- 2)	20,0			20,0			
		R60	- 2)	- 2)	17,7			17,7			
		R90	- 2)	- 2)	8,2			8,2			
		R120	- 2)	- 2)	3,5			3,5			
HAC-C-T A4 53/34		R30	- 2)	- 2)	20,0			20,0			
		R60	- 2)	- 2)	17,7			17,7			
		R90	- 2)	- 2)	8,2			8,2			
		R120	- 2)	- 2)	3,5			3,5			
Teilsicherheitsbeiwert			$\gamma_{Ms,fi}^{1)}$	[-]	1,0						

¹⁾ Sofern andere nationale Regelungen fehlen

²⁾ Produkt nicht vorhanden

Ankerschienen (HAC-C) mit Spezialschrauben (HBC)

Leistung

Charakteristische Widerstände der Ankerschienen und Spezialschrauben unter Brandbeanspruchung

Anhang C25

Tabelle 54: Charakteristische Widerstände der Ankerschienen unter Brandbeanspruchung – Stahlversagen für HAC-C(-P) (warmgewalzte) Ankerschienen

Spezialschrauben				M10	M12	M16	M20	
Stahlversagen: Anker, Verbindung zwischen Anker und Schiene und Aufbiegen der Schienenlippe								
Stahl und Nichtrostender Stahl (A4)								
Charakterischer Widerstand unter Brandbeanspruchung	HAC-C(-P) 40/22 HAC-C-P 40L	R60	$N_{Rk,s,fi}$ = $V_{Rk,s,y,fi}$	[kN]	- ³⁾	- ³⁾	3,5	- ²⁾
		R90					2,2	
		R120					1,5	
	HAC-C(-P) 50/30 HAC-C-P 50L HAC-C 52/34	R60			- ²⁾	3,8	3,9	
		R90				2,5	2,9	
		R120				1,9	2,4	
Teilsicherheitsbeiwert			$\gamma_{Ms,fi}$ ¹⁾	[-]	1,0			

1) Sofern andere nationale Regelungen fehlen

2) Produkt nicht vorhanden

3) Leistung nicht bewertet

Tabelle 55: Charakteristische Widerstände der Ankerschienen unter Brandbeanspruchung – Stahlversagen für HAC-C (kaltverformte) Ankerschienen

Spezialschrauben				M10	M12	M16	M20		
Stahlversagen: Anker, Verbindung zwischen Anker und Schiene und Aufbiegen der Schienenlippe									
Stahl und Nichtrostender Stahl (A4)									
Charakterischer Widerstand in gerissenem Beton	HAC-C 28/15	R60	$N_{Rk,s,fi}$ = $V_{Rk,s,y,fi}$	[kN]	0,8		- ²⁾	- ²⁾	
		R90			0,6				
		R120			0,5				
	HAC-C 38/17	R60			- ³⁾	- ³⁾	1,9		- ²⁾
		R90					1,3		
		R120					1,0		
	HAC-C 40/25	R60			1,7		3,5		- ²⁾
		R90			1,2		2,2		
		R120			0,9		1,5		
	HAC-C 49/30	R60			- ²⁾	3,8		3,9	
		R90				2,5		2,9	
		R120				1,9		2,4	
Teilsicherheitsbeiwert			$\gamma_{Ms,fi}$ ¹⁾	[-]	1,0				

1) Sofern andere nationale Regelungen fehlen

2) Produkt nicht vorhanden

3) Leistung nicht bewertet

Ankerschienen (HAC-C) mit Spezialschrauben (HBC)

Leistung

Charakteristische Widerstände der Ankerschienen und Spezialschrauben unter Brandbeanspruchung

Anhang C26

**Tabelle 56: Minimaler Achsabstand der Bewehrung –
für HAC-C-T (warmgewalzte gezahnte) Ankerschienen**

Ankerschiene				HAC-C-T 29/20	HAC-C-T 40/22	HAC-C-T 40L	HAC-C-T 50/30	HAC-C-T 50L	HAC-C-T 53/34
Minimaler Achsabstand	R30	a	[mm]	35			50		
	R60			35			50		
	R90			45			50		
	R120			55			55		

**Tabelle 57: Minimaler Achsabstand der Bewehrung –
für HAC-C (kaltverformte) und HAC-C(-P) (warmgewalzte) Ankerschienen**

Ankerschiene				HAC-C 28/15	HAC-C 38/17	HAC-C 40/25	HAC-C(-P) 40/22	HAC-C-P 40L	HAC-C 49/30	HAC-C(-P) 50/30	HAC-C-P 50L	HAC-C 54/33	HAC-C 52/34
Minimaler Achsabstand	R60	a	[mm]	35					50				
	R90			45					50				
	R120			55					55				

Einseitige Brandbeanspruchung

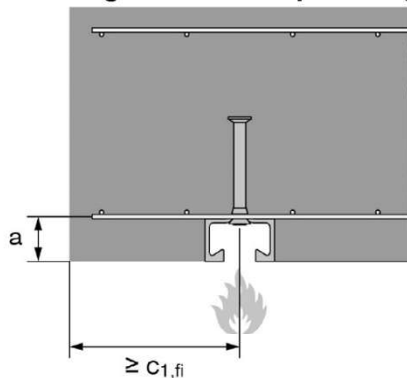

Mehrseitige Brandbeanspruchung

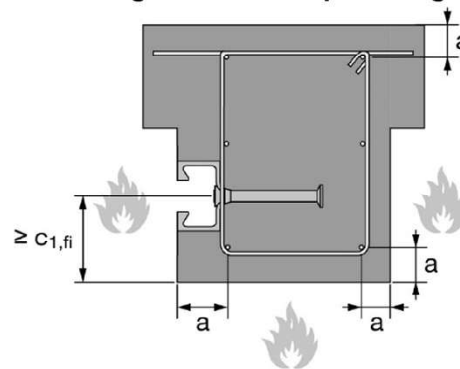

Ankerschienen (HAC-C) mit Spezialschrauben (HBC)

Leistung

Charakteristische Widerstände der Ankerschienen und Spezialschrauben unter Brandbeanspruchung

Anhang C27