



X-C G3 MX

Concrete nails (collated)

Data Sheet

[English](#)

[Deutsch](#)

[Français](#)

[Español](#)

[Italiano](#)

[Polski](#)





X-C G3 MX

Concrete nails (collated)

Data Sheet

[English](#)



25 Aug 2025

CONTENTS

1	Product information	2
1.1	Product description	2
2	Intended use	2
2.1	Fastening conditions	2
2.2	Base materials	2
2.3	Load conditions	2
2.4	Environmental conditions	3
3	Product data	3
3.1	Dimensions	3
3.2	Material properties for carbon steel parts	3
3.3	Material properties for plastic parts	3
4	System recommendation	4
4.1	Tool recommendation	4
5	Requirements for intended use	4
5.1	Fastened material properties	4
5.2	Base material properties	5
5.3	Nail length recommendation	5
6	Performance data	6
6.1	Recommended loads under quasi static loading	6
6.2	Stick rate estimation	6
7	Quality assurance	7
7.1	Fastening inspection	7
8	Ordering information	7
8.1	Item number and description	7

1 PRODUCT INFORMATION

1.1 Product description

Designation	Features
X-C G3 MX 	<ul style="list-style-type: none"> • Premium nail for excellent performance on soft concrete • Everyday fastening solution with cut-tip nail

2 INTENDED USE

2.1 Fastening conditions

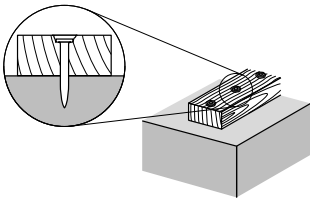
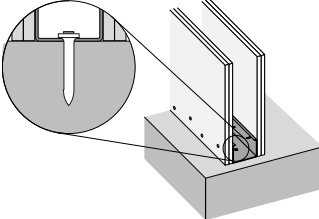
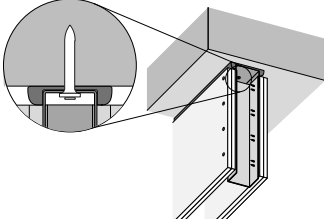
		
Wood to concrete	Fixed track fastening	Deflection head track fastening (optional with sealant)

2.2 Base materials

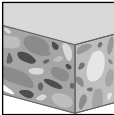
Concrete

2.3 Load conditions

Static / quasi-static

2.4 Environmental conditions

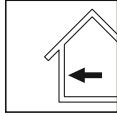

Dry indoor



• For more details, please refer to the [Hilti Corrosion Handbook](#).

3 PRODUCT DATA

3.1 Dimensions

Technical drawing	Fastener	Head length	Shank length	Shank diameter	Head diameter
		L_h [mm]	L_s [mm]	d_s [mm]	d_h [mm]
	X-C 20 G3 MX	1.9	19	3	6.5
	X-C 27 G3 MX	1.9	27	3	6.5
	X-C 32 G3 MX	1.9	30	3	6.5
	X-C 39 G3 MX	1.9	38.5	2.6	5.8

3.2 Material properties for carbon steel parts

Fastener	Component part	Material	Coating	Coating thickness	Hardness	Corrosivity category
				t_c [μm]	[HRC]	
X-C G3 MX	Nail	Carbon steel	Zinc coated	≥ 5	56.5	C1



• Corrosivity category of the atmosphere according to EN ISO 9223.

3.3 Material properties for plastic parts

Fastener	Component part	Material	Color
X-C G3 MX	Magazine strip	High Density Polyethylene (HDPE)	Grey

4 SYSTEM RECOMMENDATION

4.1 Tool recommendation

Fastening condition	Fastener	Tool type
Wood to concrete, Fixed track fastening, Deflection head track fastening (optional with sealant)	X-C G3 MX	GX 3-ME, GX 3



• For more details, please refer to the chapter Accessories and consumables compatibility in the [Direct Fastening Technology Manual \(DFTM\)](#).

5 REQUIREMENTS FOR INTENDED USE

5.1 Fastened material properties

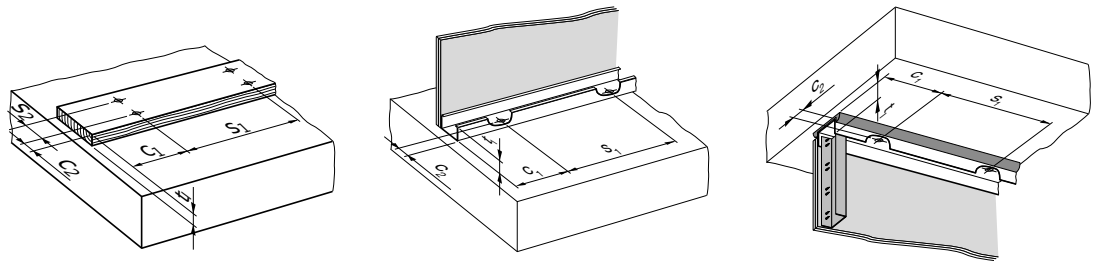

Fastening condition	Fastener	Fastened material	Fastened material thickness t_1 [mm]	Edge distance c_1 [mm]	Edge distance c_2 [mm]	Fastener spacing distance s_1 [mm]	Fastener spacing distance s_2 [mm]
Wood to concrete	X-C G3 MX	Wood	≤ 25	≥ 100	≥ 22	180–800	≥ 80
Fixed track fastening	X-C G3 MX	Steel track	≤ 1	≥ 40		≤ 600	≥ 80
Deflection head track fastening (optional with sealant)	X-C G3 MX	Steel track, Hilti CSF-TTS or sealant	≤ 3.5				

5.2 Base material properties

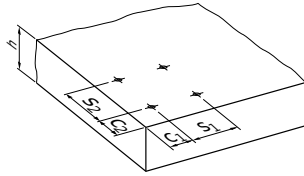

Fastening to concrete

Base material	Base material thickness h [mm]	Edge distance c ₁ [mm]	Edge distance c ₂ [mm]	Fastener spacing distance s ₁ [mm]	Fastener spacing distance s ₂ [mm]
Concrete	≥ 60	≥ 70	≥ 70	≥ 100	≥ 100

5.3 Nail length recommendation

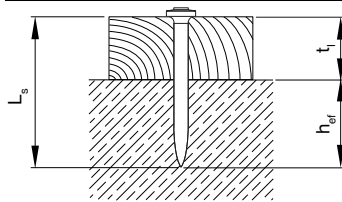

Wood to concrete

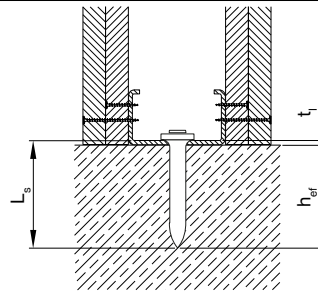

Fixed track fastening

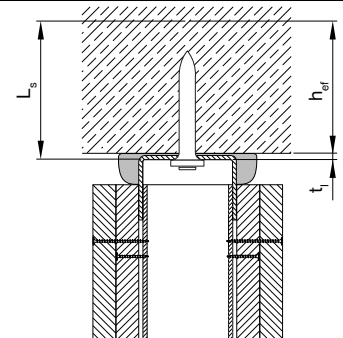

Deflection head track fastening (optional with sealant)

Fastening condition	Fastening characteristics	Shank Length	Embedment depth	Fastened material thickness
		L _s [mm]	h _{ef} [mm]	t ₁ [mm]
Wood to concrete	Standard fastening	$L_s \geq h_{ef} + t_1$	≥ 14	≤ 25
	Flush fastening	$L_s \geq h_{ef} + t_1 - 3$	≥ 14	≤ 25
Fixed track fastening	Standard fastening	$L_s \geq h_{ef} + t_1$	≥ 14	≤ 1
Deflection head track fastening (optional with sealant)	Standard fastening	$L_s \geq h_{ef} + t_1$	≥ 14	≤ 3.5

6 PERFORMANCE DATA

6.1 Recommended loads under quasi static loading

Fastening condition	Fastener	Base material type	Embedment depth	Tension load	Shear load
			h_{ef} [mm]	N_{rec} [kN]	V_{rec} [kN]
Wood to concrete, Fixed track fastening, Deflection head track fastening (optional with sealant)	X-C G3 MX	Soft concrete, Medium concrete	14 – <18	0.1	0.1
		Soft concrete, Medium concrete	≥ 18	0.2	0.2

6.2 Stick rate estimation

Technical drawing	Fastening condition	Base material type	Stick rate estimation [%]
	Wood to concrete, Fixed track fastening, Deflection head track fastening (optional with sealant)	Soft concrete	75 – 90
		Medium concrete	75 – 90



- Stick rate can vary from the above values depending on job site conditions.
- The stick rate indicates the percentage of nails that were driven correctly to carry a load.

7 QUALITY ASSURANCE

7.1 Fastening inspection

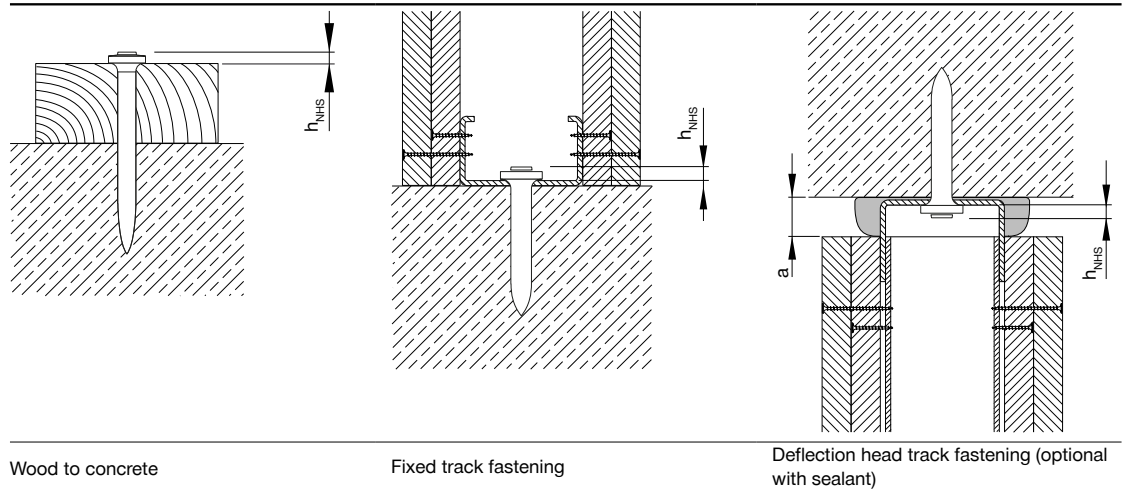

Fastening condition	Fastener	Deflection head gap a [mm]	Fastener standoff h _{NHS} [mm]
Wood to concrete	X-C G3 MX		≤ 3
Fixed track fastening	X-C G3 MX		2 – 5
Deflection head track fastening (optional with sealant)	X-C G3 MX	≤ 20	2 – 3



- Visible setting failures must be replaced with a new fastener, not in the same hole.
- These are abbreviated instructions which may vary by application.
- Always review/ follow the instructions accompanying the product.

8 ORDERING INFORMATION

8.1 Item number and description

Designation	Item number	Description
X-C 20 G3 MX	2100955, 2100959	X-C G3 MX Concrete nails (collated)
X-C 27 G3 MX	2100956, 2101040	
X-C 32 G3 MX	2100957	
X-C 39 G3 MX	2100958, 2122633	



Hilti Aktiengesellschaft
9494 Schaan, Liechtenstein
P +423-234 2965

www.facebook.com/hiltigroup
www.hilti.group



X-C G3 MX

Nägel für Beton (magaziniert)

Datenblatt

[Deutsch](#)



25.08.2025

INHALTSVERZEICHNIS

1	Produktinformationen	2
1.1	Produktbeschreibung	2
2	Vorgesehene Verwendung	2
2.1	Befestigungsbedingungen	2
2.2	Untergrundmaterial	2
2.3	Lastbedingungen	2
2.4	Umgebungsbedingungen	3
3	Produktdaten	3
3.1	Abmessungen	3
3.2	Materialeigenschaften für Teile aus Kohlenstoffstahl	3
3.3	Materialeigenschaften für Kunststoffteile	3
4	Systemempfehlung	4
4.1	Geräteempfehlung	4
5	Anforderungen an die vorgesehene Verwendung	4
5.1	Eigenschaften des befestigten Materials	4
5.2	Eigenschaften des Untergrundmaterials	5
5.3	Empfehlung zur Länge von Nägeln	5
6	Leistungsdaten	6
6.1	Empfohlene Lasten unter quasi-statischer Belastung	6
6.2	Erwartete Setzrate	6
7	Qualitätssicherung	7
7.1	Befestigungskontrolle	7
8	Bestellinformationen	7
8.1	Artikelnummer und Beschreibung	7

1 PRODUKTINFORMATIONEN

1.1 Produktbeschreibung

Bezeichnung	Besondere Eigenschaften
X-C G3 MX 	<ul style="list-style-type: none"> • Premiumnagel mit ausgezeichneter Leistung auf weichem Beton • Wirtschaftlicher Standardnagel mit geschnittener Spitze

2 VORGESEHENE VERWENDUNG

2.1 Befestigungsbedingungen

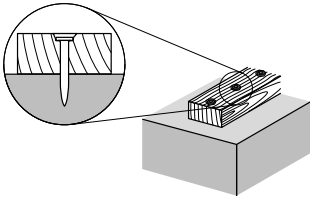
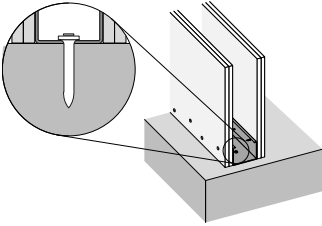
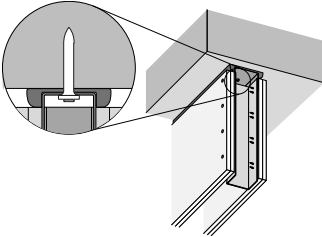
		
Holz auf Beton	Feste Profilbefestigung	Profilbefestigung Umlenkkopf (optional mit Dichtmasse)

2.2 Untergrundmaterial

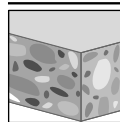

Beton

2.3 Lastbedingungen



Statisch/quasi-statisch

2.4 Umgebungsbedingungen

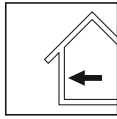

Trockene Innenräume

- Weitere Einzelheiten entnehmen Sie bitte dem [Hilti Korrosionshandbuch](#).

3 PRODUKTDATEN

3.1 Abmessungen

Technische Zeichnung	Befestigungselement	Kopflänge	Schaftlänge	Schaftdurchmesser	Kopfdurchmesser
		L_h [mm]	L_s [mm]	d_s [mm]	d_h [mm]
	X-C 20 G3 MX	1,9	19	3	6,5
	X-C 27 G3 MX	1,9	27	3	6,5
	X-C 32 G3 MX	1,9	30	3	6,5
	X-C 39 G3 MX	1,9	38,5	2,6	5,8

3.2 Materialeigenschaften für Teile aus Kohlenstoffstahl

Befestigungselement	Bauteil	Material	Beschichtung	Beschichtungsdicke	Härte	Korrosionskategorie
				t_c [µm]	[HRC]	
X-C G3 MX	Nagel	Kohlenstoffstahl	Verzinkt	≥5	56,5	C1

- Kategorie der umgebungsbedingten Korrosivität nach EN ISO 9223.

3.3 Materialeigenschaften für Kunststoffteile

Befestigungselement	Bauteil	Material	Farbe
X-C G3 MX	Streifenmagazin	HDPE (High Density Polyethylen)	Grau

4 SYSTEMEMPFEHLUNG

4.1 Geräteempfehlung

Befestigungsbedingung	Befestigungselement	Gerätetyp
Holz auf Beton, Feste Profilbefestigung, Profilbefestigung Umlenkkopf (optional mit Dichtmasse)	X-C G3 MX	GX 3-ME, GX 3

- i** • Für weitere Einzelheiten wird auf das Kapitel „Kompatibilität von Zubehör und Verbrauchsmaterialien“ im [Handbuch der Direktbefestigungstechnik \(DFTM\)](#) verwiesen.

5 ANFORDERUNGEN AN DIE VORGESEHENE VERWENDUNG

5.1 Eigenschaften des befestigten Materials

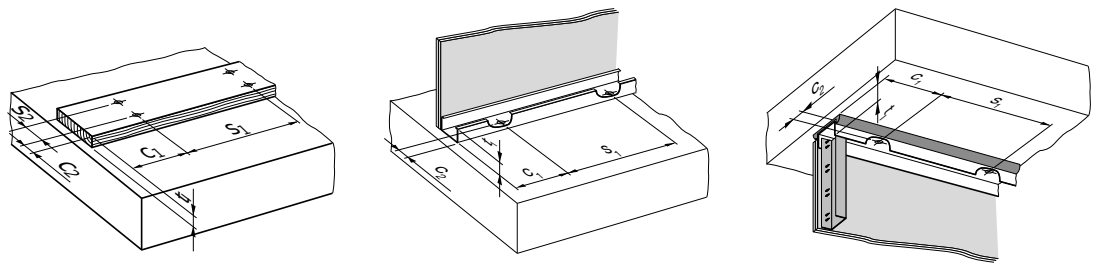

Holz auf Beton

Feste Profilbefestigung

Profilbefestigung Umlenkkopf (optional mit Dichtmasse)

Befestigungsbedingung	Befestigungselement	Befestigtes Material	Stärke des befestigten Materials	Randabstand	Randabstand	Abstände zwischen Befestigungselementen	Abstände zwischen Befestigungselementen
			t ₁ [mm]	c ₁ [mm]	c ₂ [mm]	s ₁ [mm]	s ₂ [mm]
Holz auf Beton	X-C G3 MX	Holz	≤ 25	≥ 100	≥ 22	180 – 800	≥ 80
Feste Profilbefestigung	X-C G3 MX	Stahlprofil	≤ 1	≥ 40		≤ 600	≥ 80
Profilbefestigung Umlenkkopf (optional mit Dichtmasse)	X-C G3 MX	Stahlprofil, Hilti CSF-TTS oder Dichtmasse	≤ 3,5				

5.2 Eigenschaften des Untergrundmaterials

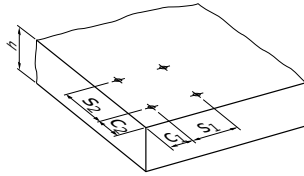

Befestigung an Beton

Untergrundmaterial	Dicke des Untergrundmaterials	Randabstand	Randabstand	Abstände zwischen Befestigungselementen	Abstände zwischen Befestigungselementen
	h [mm]	c ₁ [mm]	c ₂ [mm]	s ₁ [mm]	s ₂ [mm]
Beton	≥ 60	≥ 70	≥ 70	≥ 100	≥ 100

5.3 Empfehlung zur Länge von Nägeln

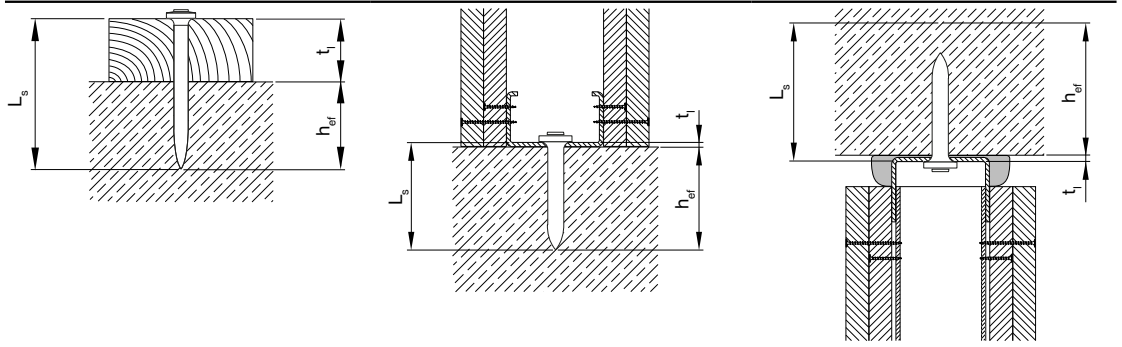

Holz auf Beton

Feste Profilbefestigung

Profilbefestigung Umlenkkopf (optional mit Dichtmasse)

Befestigungsbedingung	Befestigungsmerkmale	Schaftlänge	Verankerungstiefe	Stärke des befestigten Materials
		L _s [mm]	h _{ef} [mm]	t _i [mm]
Holz auf Beton	Standardbefestigung	$L_s \geq h_{ef} + t_i$	≥ 14	≤ 25
	Bündige Befestigung	$L_s \geq h_{ef} + t_i - 3$	≥ 14	≤ 25
Feste Profilbefestigung	Standardbefestigung	$L_s \geq h_{ef} + t_i$	≥ 14	≤ 1
Profilbefestigung Umlenkkopf (optional mit Dichtmasse)	Standardbefestigung	$L_s \geq h_{ef} + t_i$	≥ 14	≤ 3,5

6 LEISTUNGSDATEN

6.1 Empfohlene Lasten unter quasi-statischer Belastung

Befestigungsbedingung	Befestigungselement	Untergrundmaterial	Verankerungstiefe	Zuglast	Querkraft
			h_{ef} [mm]	N_{rec} [kN]	V_{rec} [kN]
Profilbefestigung Umlenkkopf (optional mit Dichtmasse), Holz auf Beton, Feste Profilbefestigung	X-C G3 MX	Weicher Beton, Mittelfester Beton	14 – < 18	0,1	0,1
		Weicher Beton, Mittelfester Beton	≥ 18	0,2	0,2

6.2 Erwartete Setzrate

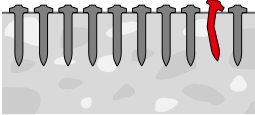
Technische Zeichnung	Befestigungsbedingung	Untergrundmaterial	Erwartete Setzrate [%]
	Profilbefestigung Umlenkkopf (optional mit Dichtmasse), Holz auf Beton, Feste Profilbefestigung	Weicher Beton	75 – 90
		Mittelfester Beton	75 – 90



- Die Setzrate kann je nach Baustellenbedingungen von den oben genannten Werten abweichen.
- Die Setzrate gibt den Anteil der Nägel an, die korrekt eingetrieben wurden, um eine Last zu tragen.

7 QUALITÄTSSICHERUNG

7.1 Befestigungskontrolle

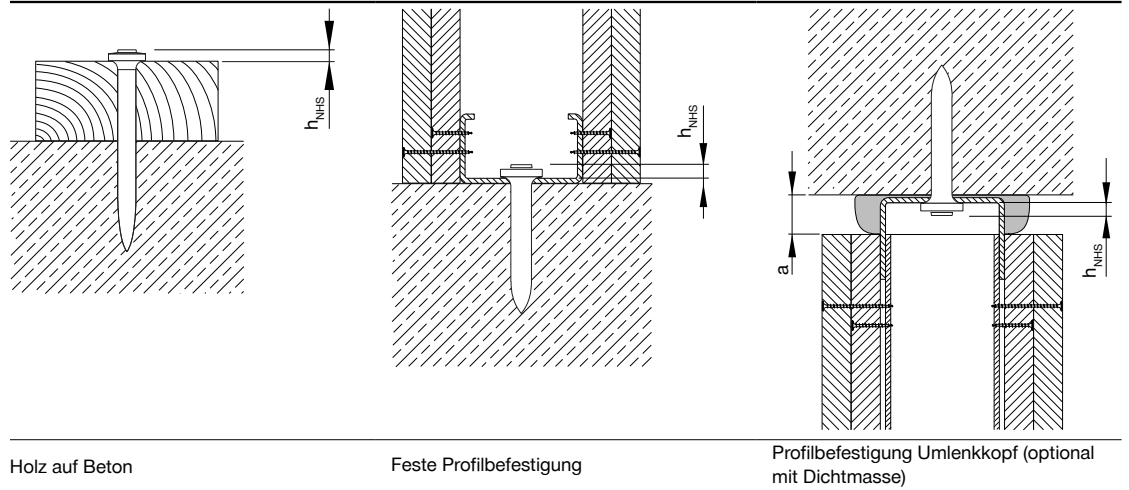

Befestigungsbedingung	Befestigungselement	Umlenkkopfspalt a [mm]	Bolzenvorstand h _{NHS} [mm]
Holz auf Beton	X-C G3 MX		≤3
Feste Profilbefestigung	X-C G3 MX		2 – 5
Profilbefestigung Umlenkopf (optional mit Dichtmasse)	X-C G3 MX	≤20	2 – 3



- Sichtbare Montagefehler sind durch ein neues Befestigungselement zu ersetzen.
- Dies ist eine gekürzte Fassung der Bedienungsanleitung. Der Wortlaut kann je nach Anwendung unterschiedlich sein.
- Beachten Sie immer die dem Produkt beiliegenden Anweisungen.

8 BESTELLINFORMATIONEN

8.1 Artikelnummer und Beschreibung

Bezeichnung	Artikelnummer	Beschreibung
X-C 20 G3 MX	2100955, 2100959	X-C G3 MX Nägel für Beton (magaziniert)
X-C 27 G3 MX	2100956, 2101040	
X-C 32 G3 MX	2100957	
X-C 39 G3 MX	2100958, 2122633	



Hilti Aktiengesellschaft
9494 Schaan, Liechtenstein
P +423-234 2965

www.facebook.com/hiltigroup
www.hilti.group



X-C G3 MX

Clous béton (en bande)

Fiche technique

[Français](#)



25 août 2025

TABLE DES MATIÈRES

1	Informations sur le produit	2
1.1	Description du produit	2
2	Utilisation prévue	2
2.1	Conditions de fixation	2
2.2	Matériaux supports	2
2.3	Conditions de charge	2
2.4	Conditions environnementales	3
3	Données produit	3
3.1	Dimensions	3
3.2	Propriétés du matériau pour pièces en acier au carbone	3
3.3	Propriétés du matériau pour pièces plastiques	3
4	Recommandation système	4
4.1	Recommandation sur l'outil	4
5	Exigences pour l'utilisation prévue	4
5.1	Propriétés du matériau fixé	4
5.2	Propriétés du matériau support	5
5.3	Longueur de clou recommandée	5
6	Données de performance	6
6.1	Charges recommandées sous les charges quasi statiques	6
6.2	Estimation du taux de réussite	6
7	Assurance qualité	7
7.1	Contrôle de la fixation	7
8	Informations de commande	7
8.1	Numéro d'article et description	7

1 INFORMATIONS SUR LE PRODUIT

1.1 Description du produit

Désignation	Caractéristiques
<p>X-C G3 MX</p> 	<ul style="list-style-type: none"> • Clou de haute qualité pour une excellente performance dans le béton tendre • Clou standard et économique avec pointe coupée

2 UTILISATION PRÉVUE

2.1 Conditions de fixation

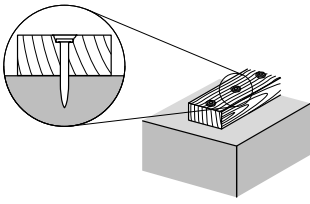
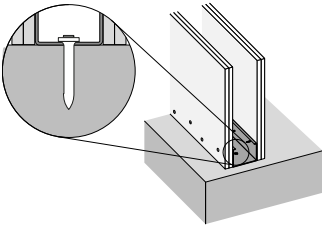
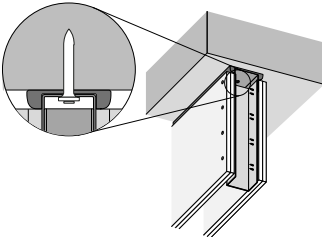
		
Bois sur béton	Fixation du rail fixe	Fixation de rails à tête de déflexion (en option avec matériau d'étanchéité)

2.2 Matériaux supports

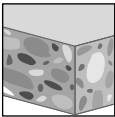
Béton

2.3 Conditions de charge

Statique/quasi statique

2.4 Conditions environnementales

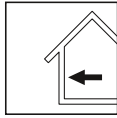

Milieu intérieur sec



- Pour de plus amples informations, veuillez vous reporter à [manuel sur la corrosion Hilti](#).

3 DONNÉES PRODUIT

3.1 Dimensions

Dessin technique	Fixation	Longueur de tête	Longueur de la tige	Diamètre de la tige	Diamètre de tête
		L_h [mm]	L_s [mm]	d_s [mm]	d_h [mm]
	X-C 20 G3 MX	1,9	19	3	6,5
	X-C 27 G3 MX	1,9	27	3	6,5
	X-C 32 G3 MX	1,9	30	3	6,5
	X-C 39 G3 MX	1,9	38,5	2,6	5,8

3.2 Propriétés du matériau pour pièces en acier au carbone

Fixation	Pièce de composant	Matériau	Revêtements	Épaisseur du revêtement	Dureté	Catégorie de corrosivité
				t_c [μm]	[HRC]	
X-C G3 MX	Clou	Acier au carbone	Recouvert de zinc	≥ 5	56,5	C1



- Catégorie de corrosivité de l'atmosphère selon la norme EN ISO 9223.

3.3 Propriétés du matériau pour pièces plastiques

Fixation	Pièce de composant	Matériau	Couleur
X-C G3 MX	Magasin à bandes	Polyéthylène haute densité (HDPE)	Gris

4 RECOMMANDATION SYSTÈME

4.1 Recommandation sur l'outil

Conditions de fixation	Fixation	Type d'outil
Bois sur béton, Fixation du rail fixe, Fixation de rails à tête de déflexion (en option avec matériau d'étanchéité)	X-C G3 MX	GX 3-ME, GX 3



- Pour plus de détails, veuillez vous reporter au chapitre sur la compatibilité des accessoires et des consommables dans le [Guide sur la technologie de clouage \(DFTM\)](#).

5 EXIGENCES POUR L'UTILISATION PRÉVUE

5.1 Propriétés du matériau fixé

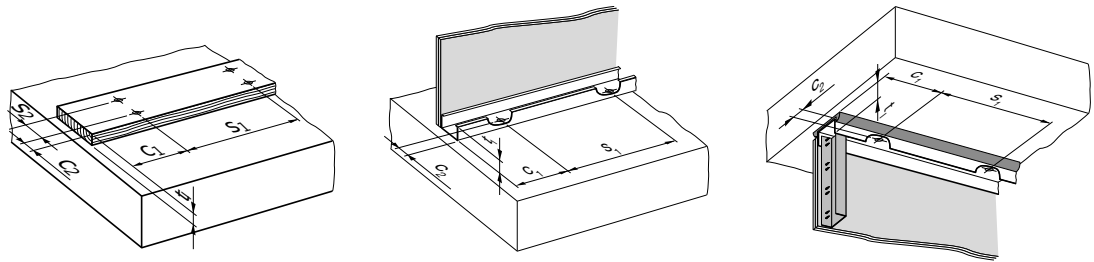

Bois sur béton

Fixation du rail fixe

Fixation de rails à tête de déflexion (en option avec matériau d'étanchéité)

Conditions de fixation	Fixation	Matériau fixé	Épaisseur du matériau fixé	Distance au bord	Distance au bord	Distance d'écartement entre les fixations	Distance d'écartement entre les fixations
			t ₁ [mm]	c ₁ [mm]	c ₂ [mm]	s ₁ [mm]	s ₂ [mm]
Bois sur béton	X-C G3 MX	Bois	≤ 25	≥ 100	≥ 22	180 – 800	≥ 80
Fixation du rail fixe	X-C G3 MX	Rail en acier	≤ 1	≥ 40		≤ 600	≥ 80
Fixation de rails à tête de déflexion (en option avec matériau d'étanchéité)	X-C G3 MX	Rail en acier, Hilti CSF-TTS ou scellant	≤ 3,5				

5.2 Propriétés du matériau support

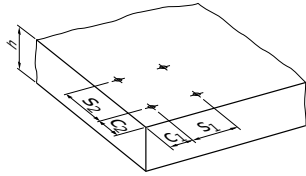

Fixation au béton

Matériau support	Épaisseur du matériau support	Distance au bord	Distance au bord	Distance d'écartement entre les fixations	Distance d'écartement entre les fixations
	h [mm]	c ₁ [mm]	c ₂ [mm]	s ₁ [mm]	s ₂ [mm]
Béton	≥ 60	≥ 70	≥ 70	≥ 100	≥ 100

5.3 Longueur de clou recommandée

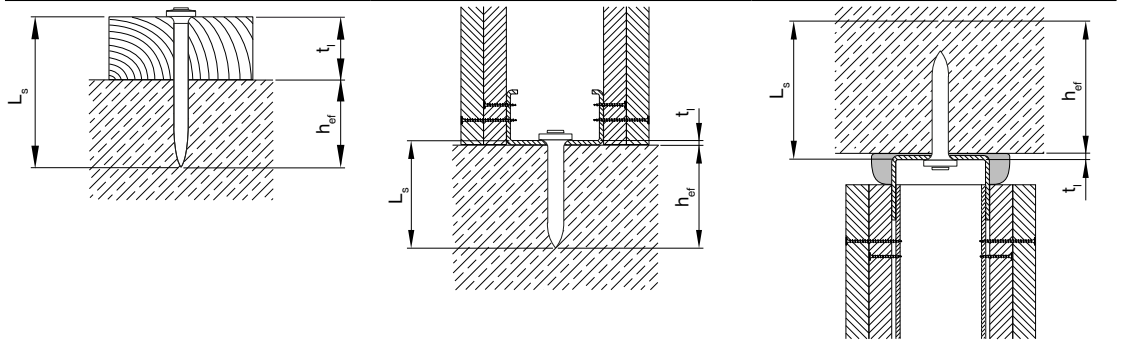

Bois sur béton

Fixation du rail fixe

Fixation de rails à tête de déflexion (en option avec matériau d'étanchéité)

Conditions de fixation	Caractéristiques de fixation	Longueur de tige	Profondeur d'implantation	Épaisseur du matériau fixé
		L _s [mm]	h _{ef} [mm]	t _i [mm]
Bois sur béton	Fixation standard	$L_s \geq h_{ef} + t_i$	≥ 14	≤ 25
	Fixation à ras	$L_s \geq h_{ef} + t_i - 3$	≥ 14	≤ 25
Fixation du rail fixe	Fixation standard	$L_s \geq h_{ef} + t_i$	≥ 14	≤ 1
Fixation de rails à tête de déflexion (en option avec matériau d'étanchéité)	Fixation standard	$L_s \geq h_{ef} + t_i$	≥ 14	≤ 3,5

6 DONNÉES DE PERFORMANCE

6.1 Charges recommandées sous les charges quasi statiques

Conditions de fixation	Fixation	Type de matériau support	Profon- deur d'implan- tation	Charge de traction	Charge de cisaille- ment
			h_{ef} [mm]	N_{rec} [kN]	V_{rec} [kN]
Fixation du rail fixe, Fixation de rails à tête de déflexion (en option avec matériau d'étanchéité), Bois sur béton	X-C G3 MX	Béton léger, Béton moyen	14 – < 18	0,1	0,1
		Béton léger, Béton moyen	≥ 18	0,2	0,2

6.2 Estimation du taux de réussite

Dessin technique	Conditions de fixation	Type de matériau support	Estimation du taux de réussite [%]
	Fixation du rail fixe, Fixation de rails à tête de déflexion (en option avec matériau d'étanchéité), Bois sur béton	Béton léger	75 – 90
		Béton moyen	75 – 90



- Le taux de réussite peut varier par rapport aux valeurs ci-dessus en fonction des conditions du chantier.
- Le taux de réussite indique le pourcentage de clous qui ont été enfoncés correctement pour porter une charge.

7 ASSURANCE QUALITÉ

7.1 Contrôle de la fixation

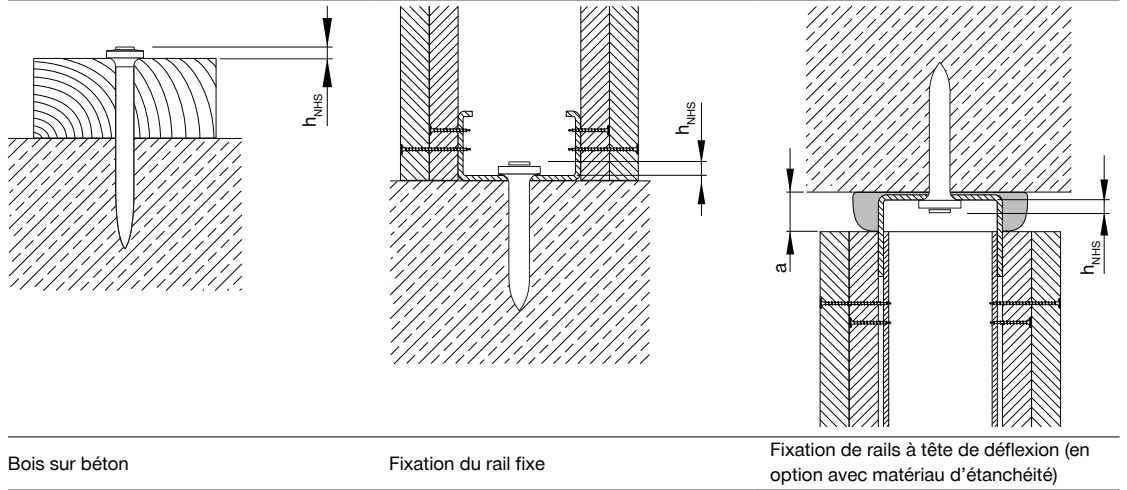

Conditions de fixation	Fixation	Écart de la tête de déflexion a [mm]	Implantation de la fixation h _{NHS} [mm]
Bois sur béton	X-C G3 MX		≤3
Fixation du rail fixe	X-C G3 MX		2-5
Fixation de rails à tête de déflexion (en option avec matériau d'étanchéité)	X-C G3 MX	≤20	2-3



- Les erreurs de pose visibles doivent être corrigées en réalisant une nouvelle fixation, avec un nouveau trou.
- Ces instructions abrégées peuvent varier selon l'application.
- Toujours consulter / suivre les instructions qui accompagnent le produit.

8 INFORMATIONS DE COMMANDE

8.1 Numéro d'article et description

Désignation	Code article	Description
X-C 20 G3 MX	2100955, 2100959	Clous X-C G3 MX béton (en bande)
X-C 27 G3 MX	2100956, 2101040	
X-C 32 G3 MX	2100957	
X-C 39 G3 MX	2100958, 2122633	



Hilti Aktiengesellschaft
9494 Schaan, Liechtenstein
P +423-234 2965

www.facebook.com/hiltigroup
www.hilti.group



X-C G3 MX

Clavos para hormigón (en tiras)

Hoja de datos

[Español](#)



25 ago. 2025

ÍNDICE

1	Información del producto	2
1.1	Descripción del producto	2
2	Uso previsto	2
2.1	Condiciones de fijación	2
2.2	Materiales base	2
2.3	Condiciones de carga	2
2.4	Condiciones ambientales	3
3	Datos del producto	3
3.1	Dimensiones	3
3.2	Propiedades del material para piezas de acero al carbono	3
3.3	Propiedades del material para piezas de plástico	3
4	Recomendación del sistema	4
4.1	Recomendación de herramienta	4
5	Requisitos para el uso previsto	4
5.1	Propiedades del material de fijación	4
5.2	Propiedades del material base	5
5.3	Recomendación de longitud de clavo	5
6	Datos de rendimiento	6
6.1	Cargas recomendadas con carga cuasiestática	6
6.2	Estimación de ratio de fijación correcta	6
7	Control de calidad	7
7.1	Inspección de fijación	7
8	Información del pedido	7
8.1	Número y descripción del artículo	7

1 INFORMACIÓN DEL PRODUCTO

1.1 Descripción del producto

Designación	Características
X-C G3 MX 	<ul style="list-style-type: none"> • Clavo de alta calidad que ofrece un excelente rendimiento en hormigón blando • Clavo estándar económico con punta cortada

2 USO PREVISTO

2.1 Condiciones de fijación

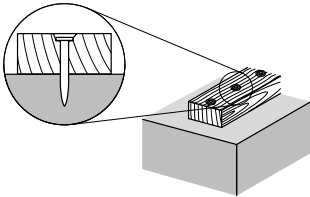
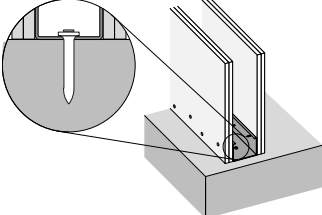
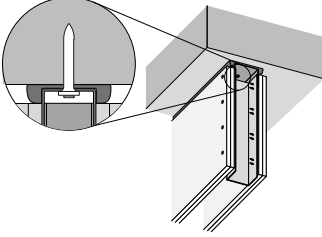
		
Madera a hormigón	Fijación de perfiles fija	Fijación de carriles con cabezal de desvío (opcional con sellador)

2.2 Materiales base

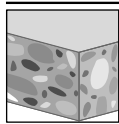

Hormigón

2.3 Condiciones de carga



Estática y cuasiestática

2.4 Condiciones ambientales

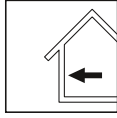

Interior seco



• Para obtener más información, consulte [Manual de corrosión de Hilti](#).

3 DATOS DEL PRODUCTO

3.1 Dimensiones

Dibujo técnico	Fijación	Longitud de cabeza	Longitud del vástago	Diámetro de vástago	Diámetro de la cabeza
		L_h [mm]	L_s [mm]	d_s [mm]	d_h [mm]
	X-C 20 G3 MX	1,9	19	3	6,5
	X-C 27 G3 MX	1,9	27	3	6,5
	X-C 32 G3 MX	1,9	30	3	6,5
	X-C 39 G3 MX	1,9	38,5	2,6	5,8

3.2 Propiedades del material para piezas de acero al carbono

Fijación	Pieza de componente	Material	Revestimiento	Espesor del revestimiento	Dureza	Categoría de corrosión
				t_c [μm]	[HRC]	
X-C G3 MX	Clavo	Acero al carbono	Con revestimiento de zinc	≥5	56,5	C1



• Categoría de corrosión de la atmósfera según la norma EN ISO 9223.

3.3 Propiedades del material para piezas de plástico

Fijación	Pieza de componente	Material	Color
X-C G3 MX	Cargador de tiras	Polietileno de alta densidad (HDPE)	Gris

5.2 Propiedades del material base

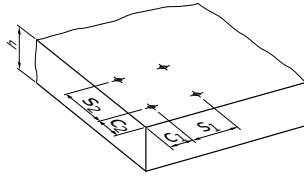

Fijación a hormigón

Material base	Espesor del material base	Distancia al borde	Distancia al borde	Distancia de separación de la fijación	Distancia de separación de la fijación
	h [mm]	c_1 [mm]	c_2 [mm]	s_1 [mm]	s_2 [mm]
Hormigón	≥ 60	≥ 70	≥ 70	≥ 100	≥ 100

5.3 Recomendación de longitud de clavo

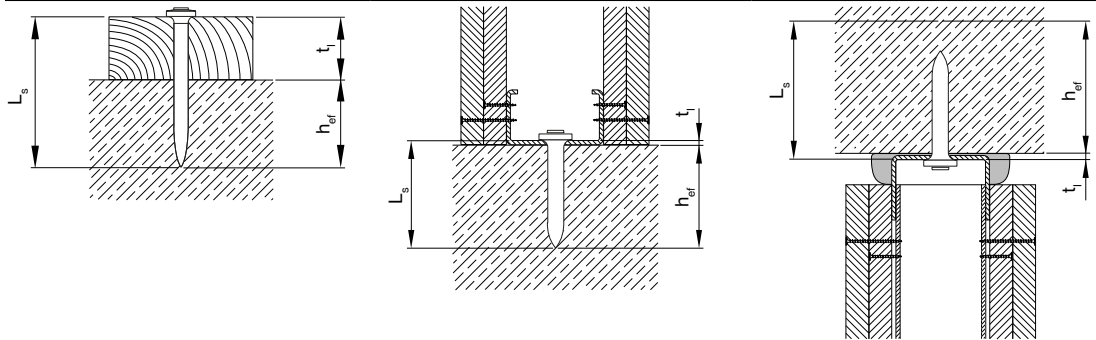

Madera a hormigón

Fijación de perfiles fija

Fijación de carriles con cabezal de desvío (opcional con sellador)

Condición de fijación	Características de fijación	Longitud del vástago	Profundidad de empotramiento	Espesor del material fijado
		L_s [mm]	h_{ef} [mm]	t_f [mm]
Madera a hormigón	Fijación estándar	$L_s \geq h_{ef} + t_f$	≥ 14	≤ 25
	Fijación a ras	$L_s \geq h_{ef} + t_f - 3$	≥ 14	≤ 25
Fijación de perfiles fija	Fijación estándar	$L_s \geq h_{ef} + t_f$	≥ 14	≤ 1
Fijación de carriles con cabezal de desvío (opcional con sellador)	Fijación estándar	$L_s \geq h_{ef} + t_f$	≥ 14	$\leq 3,5$

6 DATOS DE RENDIMIENTO

6.1 Cargas recomendadas con carga cuasiestática

Condición de fijación	Fijación	Tipo de material base	Profundi- dad de empotra- miento	Carga de tensión	Carga cortante
			h_{ef} [mm]	N_{rec} [kN]	V_{rec} [kN]
Madera a hormigón, Fijación de perfiles fija, Fijación de carriles con cabezal de desvío (opcional con sellador)	X-C G3 MX	Hormigón blando, Hormigón medio	14 - < 18	0,1	0,1
		Hormigón blando, Hormigón medio	≥ 18	0,2	0,2

6.2 Estimación de ratio de fijación correcta

Dibujo técnico	Condición de fijación	Tipo de material base	Estimación de ratio de fijación correcta [%]
	Madera a hormigón, Fijación de perfiles fija, Fijación de carriles con cabezal de desvío (opcional con sellador)	Hormigón blando	75 - 90
		Hormigón medio	75 - 90



- El ratio de fijación correcta puede variar de los valores anteriores en función de las condiciones del lugar de trabajo.
- La tasa de fijación indica el porcentaje de clavos que se colocaron correctamente para soportar una carga.

7 CONTROL DE CALIDAD

7.1 Inspección de fijación

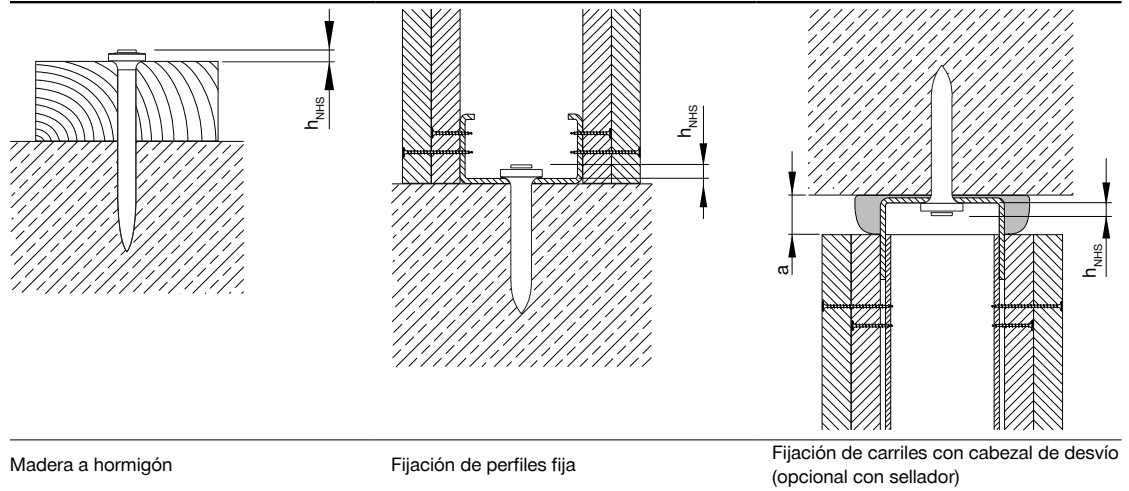

Condición de fijación	Fijación	Separación del cabezal de desvío a [mm]	Fijación con distanciador h _{NHS} [mm]
Madera a hormigón	X-C G3 MX		≤3
Fijación de perfiles fija	X-C G3 MX		2-5
Fijación de carriles con cabezal de desvío (opcional con sellador)	X-C G3 MX	≤20	2-3



- Los fallos de colocación visibles deben sustituirse por nuevas fijaciones, sin utilizar el mismo orificio.
- Estas instrucciones se encuentran abreviadas y pueden variar según la aplicación.
- Revise y siga siempre las instrucciones que acompañan al producto.

8 INFORMACIÓN DEL PEDIDO

8.1 Número y descripción del artículo

Designación	Número de elemento	Descripción
X-C 20 G3 MX	2100955, 2100959	Clavos para hormigón X-C G3 MX (en tiras)
X-C 27 G3 MX	2100956, 2101040	
X-C 32 G3 MX	2100957	
X-C 39 G3 MX	2100958, 2122633	



Hilti Aktiengesellschaft
9494 Schaan, Liechtenstein
P +423-234 2965

www.facebook.com/hiltigroup
www.hilti.group



X-C G3 MX

Chiodi per calcestruzzo (a nastro)

Scheda tecnica

[Italiano](#)



25 ago 2025

INDICE

1	Informazioni sul prodotto	2
1.1	Descrizione del prodotto	2
2	Uso previsto	2
2.1	Condizioni di fissaggio	2
2.2	Materiali di base	2
2.3	Condizioni di carico	2
2.4	Condizioni ambientali	3
3	Dati del prodotto	3
3.1	Dimensioni	3
3.2	Proprietà dei materiali per parti in acciaio al carbonio	3
3.3	Proprietà dei materiali per parti in plastica	3
4	Raccomandazioni sul sistema	4
4.1	Raccomandazioni per l'attrezzo	4
5	Requisiti per l'uso previsto	4
5.1	Caratteristiche del materiale fissato	4
5.2	Proprietà del materiale di base	5
5.3	Lunghezza del chiodo consigliata	5
6	Dati sulle prestazioni	6
6.1	Carichi raccomandati in caso carico quasi statico	6
6.2	Stima del tasso di trucioli	6
7	Assicurazione qualità	7
7.1	Ispezione fissaggio	7
8	Informazioni per l'ordine	7
8.1	Numero articolo e descrizione	7

1 INFORMAZIONI SUL PRODOTTO

1.1 Descrizione del prodotto

Denominazione	Vantaggi
<p>X-C G3 MX</p> 	<ul style="list-style-type: none"> • Chiodo premium per prestazioni eccellenti sul calcestruzzo morbido • Chiodo standard economico con punta da taglio

2 USO PREVISTO

2.1 Condizioni di fissaggio

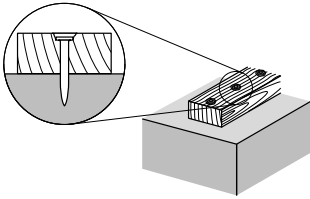
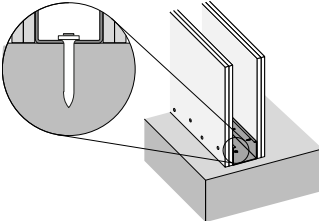
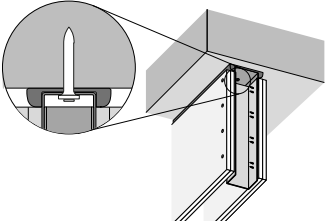
		
Legno su calcestruzzo	Fissaggio guida fissa	Fissaggio del binario della testa di deviazione (in via opzionale con sigillante)

2.2 Materiali di base

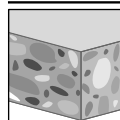

Calcestruzzo

2.3 Condizioni di carico



Statico/quasi statico

2.4 Condizioni ambientali

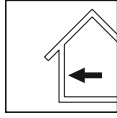

Interni asciutti



- Per maggiori dettagli, fare riferimento a [Hilti Corrosion Handbook](#) (Manuale sulla corrosione Hilti).

3 DATI DEL PRODOTTO

3.1 Dimensioni

Disegno tecnico	Elemento di fissaggio	Lunghezza testa	Lunghezza gambo	Diametro gambo	Diametro testa
		L_h [mm]	L_s [mm]	d_s [mm]	d_h [mm]
	X-C 20 G3 MX	1,9	19	3	6,5
	X-C 27 G3 MX	1,9	27	3	6,5
	X-C 32 G3 MX	1,9	30	3	6,5
	X-C 39 G3 MX	1,9	38,5	2,6	5,8

3.2 Proprietà dei materiali per parti in acciaio al carbonio

Elemento di fissaggio	Parte del componente	Materiale	Rivestimento	Spessore di rivestimento	Durezza	Categoria di corrosività
				t_c [μ m]	[HRC]	
X-C G3 MX	Chiodo	Acciaio al carbonio	Zincato	≥ 5	56,5	C1



- Categoria di corrosività dell'atmosfera secondo EN ISO 9223.

3.3 Proprietà dei materiali per parti in plastica

Elemento di fissaggio	Parte del componente	Materiale	Colore
X-C G3 MX	Magazzino a strisce	Polietilene ad alta densità (HDPE)	Grigio

4 RACCOMANDAZIONI SUL SISTEMA

4.1 Raccomandazioni per l'attrezzo

Condizione di fissaggio	Elemento di fissaggio	Tipo di attrezzo
Legno su calcestruzzo, Fissaggio guida fissa, Fissaggio del binario della testa di deviazione (in via opzionale con sigillante)	X-C G3 MX	GX 3-ME, GX 3



- Per maggiori dettagli, fare riferimento al capitolo Compatibilità di accessori e materiali di consumo all'indirizzo [Direct Fastening Technology Manual \(DFTM\)](#) (Manuale del fissaggio diretto).

5 REQUISITI PER L'USO PREVISTO

5.1 Caratteristiche del materiale fissato

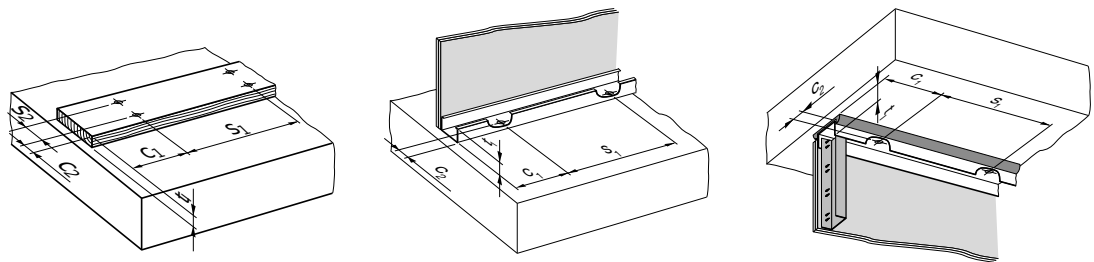

Legno su calcestruzzo	Fissaggio guida fissa	Fissaggio del binario della testa di deviazione (in via opzionale con sigillante)
-----------------------	-----------------------	---

Condizione di fissaggio	Elemento di fissaggio	Materiale fissato	Spessore materiale fissato	Distanza dal bordo	Distanza dal bordo	Distanza dall'elemento di fissaggio	Distanza dall'elemento di fissaggio
			t ₁ [mm]	c ₁ [mm]	c ₂ [mm]	s ₁ [mm]	s ₂ [mm]
Legno su calcestruzzo	X-C G3 MX	Legno	≤ 25	≥ 100	≥ 22	180 - 800	≥ 80
Fissaggio guida fissa	X-C G3 MX	Binari d'acciaio	≤ 1	≥ 40		≤ 600	≥ 80
Fissaggio del binario della testa di deviazione (in via opzionale con sigillante)	X-C G3 MX	Pannelli d'acciaio, Hilti CSF-TTS o sigillante	≤ 3,5				

5.2 Proprietà del materiale di base

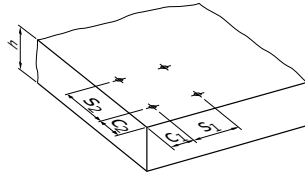

Fissaggio su calcestruzzo

Materiale di base	Spessore materiale di base	Distanza dal bordo	Distanza dal bordo	Distanza dall'elemento di fissaggio	Distanza dall'elemento di fissaggio
	h [mm]	c_1 [mm]	c_2 [mm]	s_1 [mm]	s_2 [mm]
Calcestruzzo	≥ 60	≥ 70	≥ 70	≥ 100	≥ 100

5.3 Lunghezza del chiodo consigliata

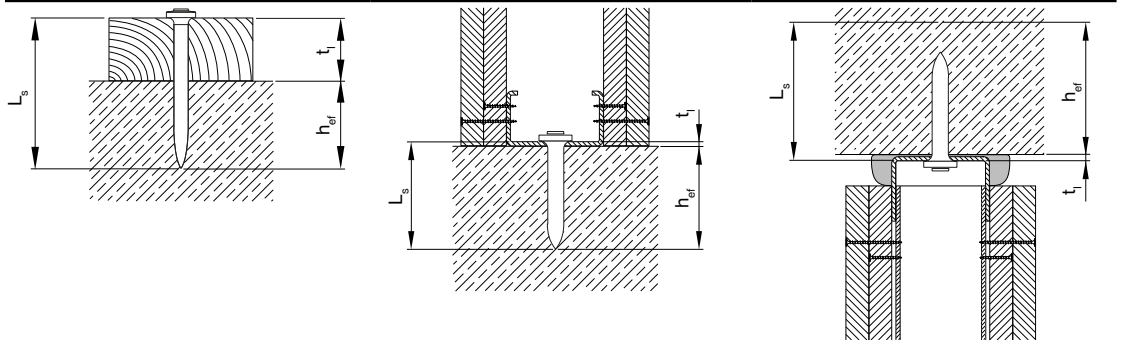

Legno su calcestruzzo

Fissaggio guida fissa

Fissaggio del binario della testa di deviazione (in via opzionale con sigillante)

Condizione di fissaggio	Caratteristiche di fissaggio	Lunghezza gambo	Profondità di posa	Spessore materiale fissato
		L_s [mm]	h_{ef} [mm]	t_i [mm]
Legno su calcestruzzo	Fissazione standard	$L_s \geq h_{ef} + t_i$	≥ 14	≤ 25
	Fissaggio a filo	$L_s \geq h_{ef} + t_i - 3$	≥ 14	≤ 25
Fissaggio guida fissa	Fissazione standard	$L_s \geq h_{ef} + t_i$	≥ 14	≤ 1
Fissaggio del binario della testa di deviazione (in via opzionale con sigillante)	Fissazione standard	$L_s \geq h_{ef} + t_i$	≥ 14	$\leq 3,5$

6 DATI SULLE PRESTAZIONI

6.1 Carichi raccomandati in caso carico quasi statico

Condizione di fissaggio	Elemento di fissaggio	Tipo di materiale base	Profondità di posa	Carico a trazione	Carico di taglio
			h_{ef} [mm]	N_{rec} [kN]	V_{rec} [kN]
Legno su calcestruzzo, Fissaggio guida fissa, Fissaggio del binario della testa di deviazione (in via opzionale con sigillante)	X-C G3 MX	Cemento morbido, Calcestruzzo medio	14 - < 18	0,1	0,1
		Cemento morbido, Calcestruzzo medio	≥ 18	0,2	0,2

6.2 Stima del tasso di trucioli

Disegno tecnico	Condizione di fissaggio	Tipo di materiale base	Stima del tasso di trucioli [%]
	Legno su calcestruzzo, Fissaggio guida fissa, Fissaggio del binario della testa di deviazione (in via opzionale con sigillante)	Cemento morbido	75 - 90
		Calcestruzzo medio	75 - 90



- Il tasso di trucioli può variare dai valori sopracitati a seconda delle condizioni in cantiere.
- Il tasso di trucioli indica la percentuale di chiodi inseriti correttamente per sostenere il carico.

7 ASSICURAZIONE QUALITÀ

7.1 Ispezione fissaggio

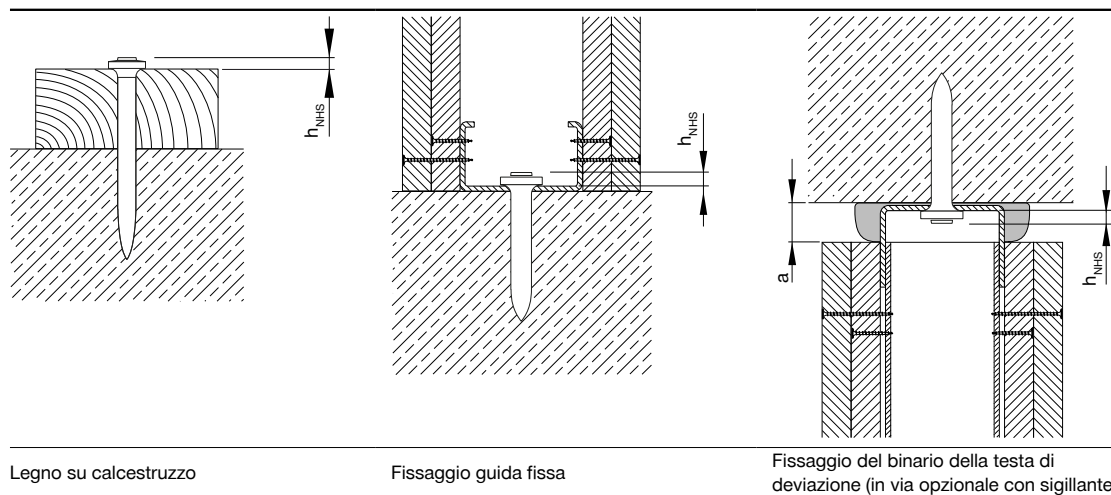

Condizione di fissaggio	Elemento di fissaggio	Spazio della testa di deviazione	Distanziatore chiodo
		a [mm]	h_{NHS} [mm]
Legno su calcestruzzo	X-C G3 MX		≤3
Fissaggio guida fissa	X-C G3 MX		2-5
Fissaggio del binario della testa di deviazione (in via opzionale con sigillante)	X-C G3 MX	≤20	2-3



- Gli errori di impostazione evidenti devono essere corretti sostituendo l'elemento di fissaggio, realizzando un nuovo foro.
- Di seguito sono riportate istruzioni brevi che possono variare a seconda dell'applicazione.
- Consultare/seguire sempre le istruzioni allegate al prodotto.

8 INFORMAZIONI PER L'ORDINE

8.1 Numero articolo e descrizione

Denominazione	Codice articolo	Descrizione
X-C 20 G3 MX	2100955, 2100959	Chiodi per calcestruzzo X-C G3 MX (a nastro)
X-C 27 G3 MX	2100956, 2101040	
X-C 32 G3 MX	2100957	
X-C 39 G3 MX	2100958, 2122633	



Hilti Aktiengesellschaft
9494 Schaan, Liechtenstein
P +423-234 2965

www.facebook.com/hiltigroup
www.hilti.group



X-C G3 MX

**Gwoździe do betonu
(magazynkowane)**

Karta danych

Polski



SPIS TREŚCI

1	Informacje o produkcie	2
1.1	Opis produktu	2
2	Przeznaczenie	2
2.1	Warunki mocowania	2
2.2	Materiały podłoża	2
2.3	Warunki obciążenia	2
2.4	Warunki środowiskowe	3
3	Dane produktu	3
3.1	Wymiary	3
3.2	Właściwości materiału dla części ze stali węglowej	3
3.3	Właściwości materiału dla elementów z tworzyw sztucznych	3
4	Zalecenie systemu	4
4.1	Narzędzie polecane	4
5	Wymagania dotyczące zamierzonych zastosowań	4
5.1	Właściwości zamocowanego materiału	4
5.2	Właściwości materiału podłoża	5
5.3	Zalecana długość gwoździ	5
6	Dane właściwości	6
6.1	Zalecane obciążenia przy obciążeniu kwazistatycznym	6
6.2	Ocena współczynnika mocowania	6
7	Zapewnianie jakości	7
7.1	Inspekcja mocowania	7
8	Informacje dotyczące zamawiania	7
8.1	Nr artykułu i opis	7

1 INFORMACJE O PRODUKCIE

1.1 Opis produktu

Oznaczenie	Cechy
X-C G3 MX 	<ul style="list-style-type: none"> Gwóźdź klasy Premium zapewniający dużą wydajność wykonywania zamocowań w miękkim betonie Ekonomiczny, standardowy gwóźdź z prasowanym wierzchołkiem

2 PRZEZNACZENIE

2.1 Warunki mocowania

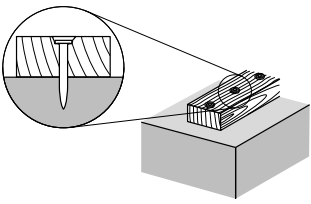
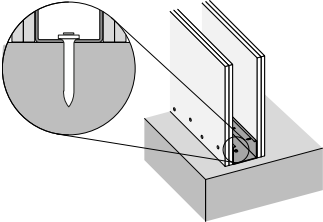
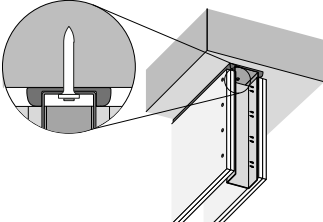
		
Drewno do betonu	Stałe mocowanie profilu	Mocowanie szyny połączenia przesuwnej (opcjonalnie z uszczelniaczem)

2.2 Materiały podłoża

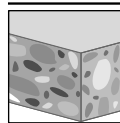

Beton

2.3 Warunki obciążenia

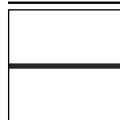

Statyczny/kwazistatyczny

2.4 Warunki środowiskowe

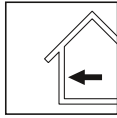

Suche, wewnątrz

- Aby uzyskać więcej informacji, zapoznaj się z informacjami na stronie [Hilti Corrosion Handbook](#).

3 DANE PRODUKTU

3.1 Wymiary

Rysunek techniczny	Elementy mocujące	Długość główicy L_h [mm]	Długość trzcienia L_s [mm]	Średnica trzcienia d_s [mm]	Średnica główicy d_h [mm]
	X-C 20 G3 MX	1,9	19	3	6,5
	X-C 27 G3 MX	1,9	27	3	6,5
	X-C 32 G3 MX	1,9	30	3	6,5
	X-C 39 G3 MX	1,9	38,5	2,6	5,8

3.2 Właściwości materiału dla części ze stali węglowej

Elementy mocujące	Część składowa	Materiał	Powłoka	Grubość powłoki t_c [μm]	Twardość [HRC]	Kategoria korozyjności
X-C G3 MX	Gwóźdź	Stal węglowa	Ocynkowane	≥5	56,5	C1

- Kategoria korozyjności w atmosferze, zgodnie z normą EN ISO 9223.

3.3 Właściwości materiału dla elementów z tworzyw sztucznych

Elementy mocujące	Część składowa	Materiał	Kolor
X-C G3 MX	Magazynek taśmowy	Polietylen o dużej gęstości (HDPE)	Szary

4 ZALECENIE SYSTEMU

4.1 Narzędzie polecane

Warunek mocowania	Elementy mocujące	Rodzaj urządzenia
Drewno do betonu, Stałe mocowanie profilu, Mocowanie szyny połączenia przesuwne (opcjonalnie z uszczelniaczem)	X-C G3 MX	GX 3-ME, GX 3



• Szczegółowe informacje zamieszczono w rozdziale Akcesoria i zgodność materiałów eksploatacyjnych w [Podręcznik techniki kotwienia \(DTM\)](#)

5 WYMAGANIA DOTYCZĄCE ZAMIERZONYCH ZASTOSOWAŃ

5.1 Właściwości zamocowanego materiału

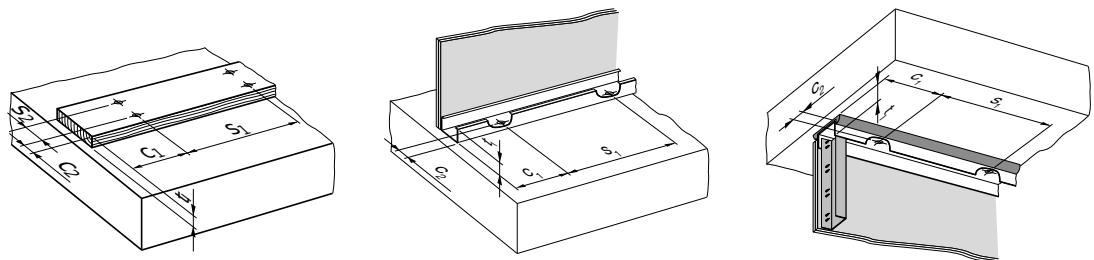

Drewno do betonu

Stałe mocowanie profilu

Mocowanie szyny połączenia przesuwne (opcjonalnie z uszczelniaczem)

Warunek mocowania	Elementy mocujące	Zamocowany materiał	Grubość mocowanego materiału t_1 [mm]	Odległość od krawędzi c_1 [mm]	Odległość od krawędzi c_2 [mm]	Odległość między elementami mocującymi s_1 [mm]	Odległość między elementami mocującymi s_2 [mm]
Drewno do betonu	X-C G3 MX	Drewno	≤ 25	≥ 100	≥ 22	180 – 800	≥ 80
Stałe mocowanie profilu	X-C G3 MX	Tor stalowy	≤ 1	≥ 40		≤ 600	≥ 80
Mocowanie szyny połączenia przesuwne (opcjonalnie z uszczelniaczem)	X-C G3 MX	Szyna stalowa, Hilti CSF-TTS lub uszczelniacz	$\leq 3,5$				

5.2 Właściwości materiału podłoża

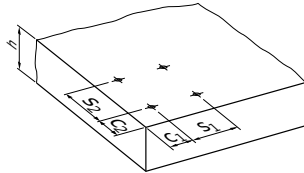

Mocowanie do betonu

Materiał podłoża	Grubość materiału podłoża	Odległość od krawędzi	Odległość od krawędzi	Odległość między elementami mocującymi	Odległość między elementami mocującymi
	h [mm]	c_1 [mm]	c_2 [mm]	s_1 [mm]	s_2 [mm]
Beton	≥ 60	≥ 70	≥ 70	≥ 100	≥ 100

5.3 Zalecana długość gwoździ

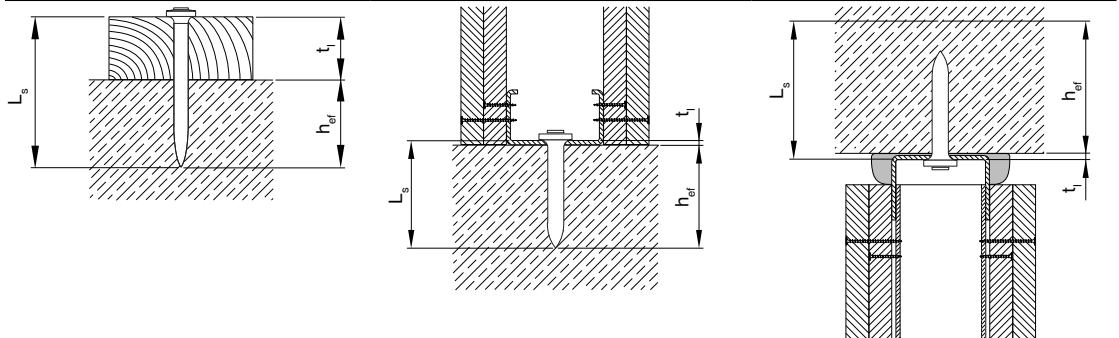

Drewno do betonu

Stałe mocowanie profilu

Mocowanie szyny połączenia przesuwne (opcjonalnie z uszczelniaczem)

Warunek mocowania	Właściwości mocowania	Długość trzpienia	Głębokość osadzenia	Grubość mocowanego materiału
		L_s [mm]	h_{ef} [mm]	t_1 [mm]
Drewno do betonu	Mocowanie standardowe	$L_s \geq h_{ef} + t_1$	≥ 14	≤ 25
	Mocowanie równo z powierzchnią	$L_s \geq h_{ef} + t_1 - 3$	≥ 14	≤ 25
Stałe mocowanie profilu	Mocowanie standardowe	$L_s \geq h_{ef} + t_1$	≥ 14	≤ 1
Mocowanie szyny połączenia przesuwne (opcjonalnie z uszczelniaczem)	Mocowanie standardowe	$L_s \geq h_{ef} + t_1$	≥ 14	$\leq 3,5$

6 DANE WŁAŚCIWOŚCI

6.1 Zalecane obciążenia przy obciążeniu kwazistatycznym

Warunek mocowania	Elementy mocujące	Rodzaj materiału podłoża	Głębokość osadzenia	Obciążenie rozciągające	Obciążenie ścinające
			h_{ef} [mm]	N_{rec} [kN]	V_{rec} [kN]
Stałe mocowanie profilu, Mocowanie szyny połączenia przesuwne (opcjonalnie z uszczelniaczem), Drewno do betonu	X-C G3 MX	Beton o wyższym stosunku w/c, Beton średni	14 – < 18	0,1	0,1
		Beton o wyższym stosunku w/c, Beton średni	≥ 18	0,2	0,2

6.2 Ocena współczynnika mocowania

Rysunek techniczny	Warunek mocowania	Rodzaj materiału podłoża	Ocena współczynnika mocowania [%]
	Stałe mocowanie profilu, Mocowanie szyny połączenia przesuwne (opcjonalnie z uszczelniaczem), Drewno do betonu	Beton o wyższym stosunku w/c	75 – 90
		Beton średni	75 – 90



- Szybkość przyklejania może różnić się od powyższych wartości w zależności od warunków w miejscu pracy.
- Współczynnik mocowania oznacza procent gwoździ, które zostały prawidłowo wbite, aby przenieść obciążenie.

7 ZAPEWNIANIE JAKOŚCI

7.1 Inspekcja mocowania

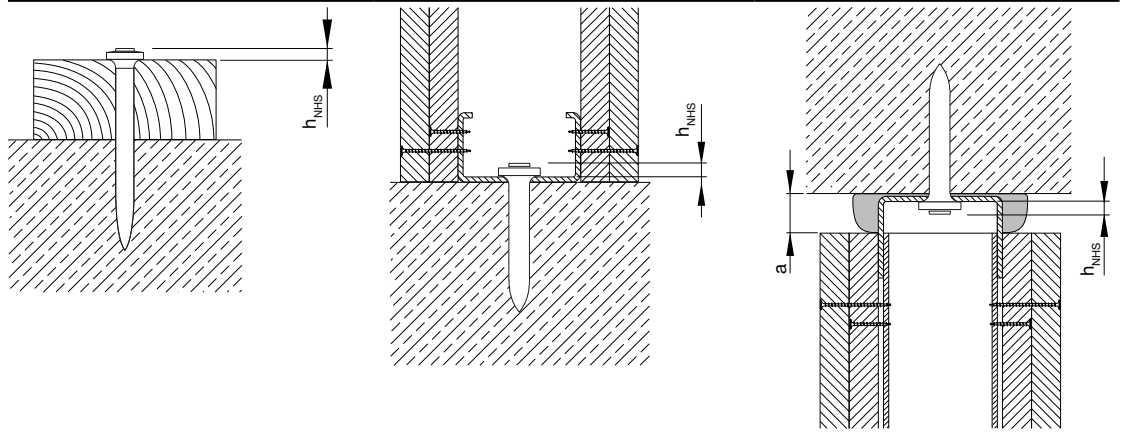

Drewno do betonu

Stałe mocowanie profilu

Mocowanie szyny połączenia przesuwne (opcjonalnie z uszczelniaczem)

Warunek mocowania	Elementy mocujące	Szczelina połączenia przesuwne a [mm]	Wystawienie łącznika h_{NHS} [mm]
Drewno do betonu	X-C G3 MX		≤ 3
Stałe mocowanie profilu	X-C G3 MX		2 – 5
Mocowanie szyny połączenia przesuwne (opcjonalnie z uszczelniaczem)	X-C G3 MX	≤ 20	2 – 3



- Widoczne wadliwe zamocowania trzeba zastąpić nowymi elementami mocującymi, nie w tym samym otworze.
- Niniejszy dokument to wersja skrócona instrukcji, mogących różnić się w zależności od zastosowania.
- Należy zawsze przestrzegać instrukcji dołączonych do danego produktu.

8 INFORMACJE DOTYCZĄCE ZAMAWIANIA

8.1 Nr artykułu i opis

Oznaczenie	Nr artykułu	Opis
X-C 20 G3 MX	2100955, 2100959	Gwoździe X-C G3 MX do betonu (magazynkowe)
X-C 27 G3 MX	2100956, 2101040	
X-C 32 G3 MX	2100957	
X-C 39 G3 MX	2100958, 2122633	



Hilti Aktiengesellschaft
9494 Schaan, Liechtenstein
P +423-234 2965

www.facebook.com/hiltigroup
www.hilti.group